

REVISIONS					
P	LTR	DESCRIPTION	DATE	DMN	APVD
M		REVISED PER ECO-15-015252	13NOV15	BJ	FY

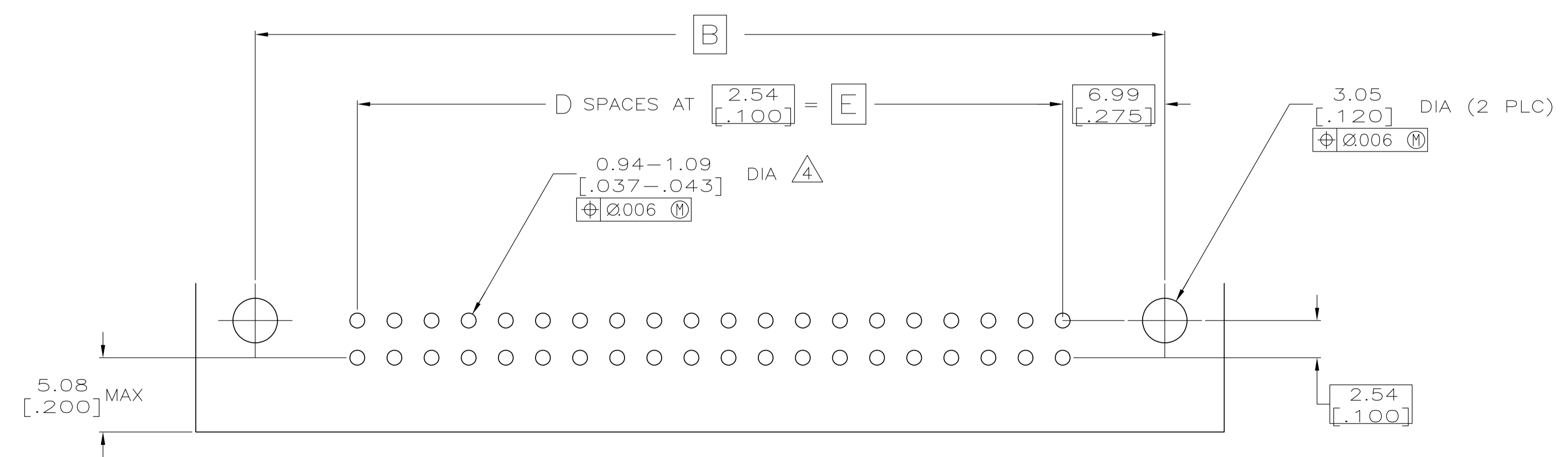
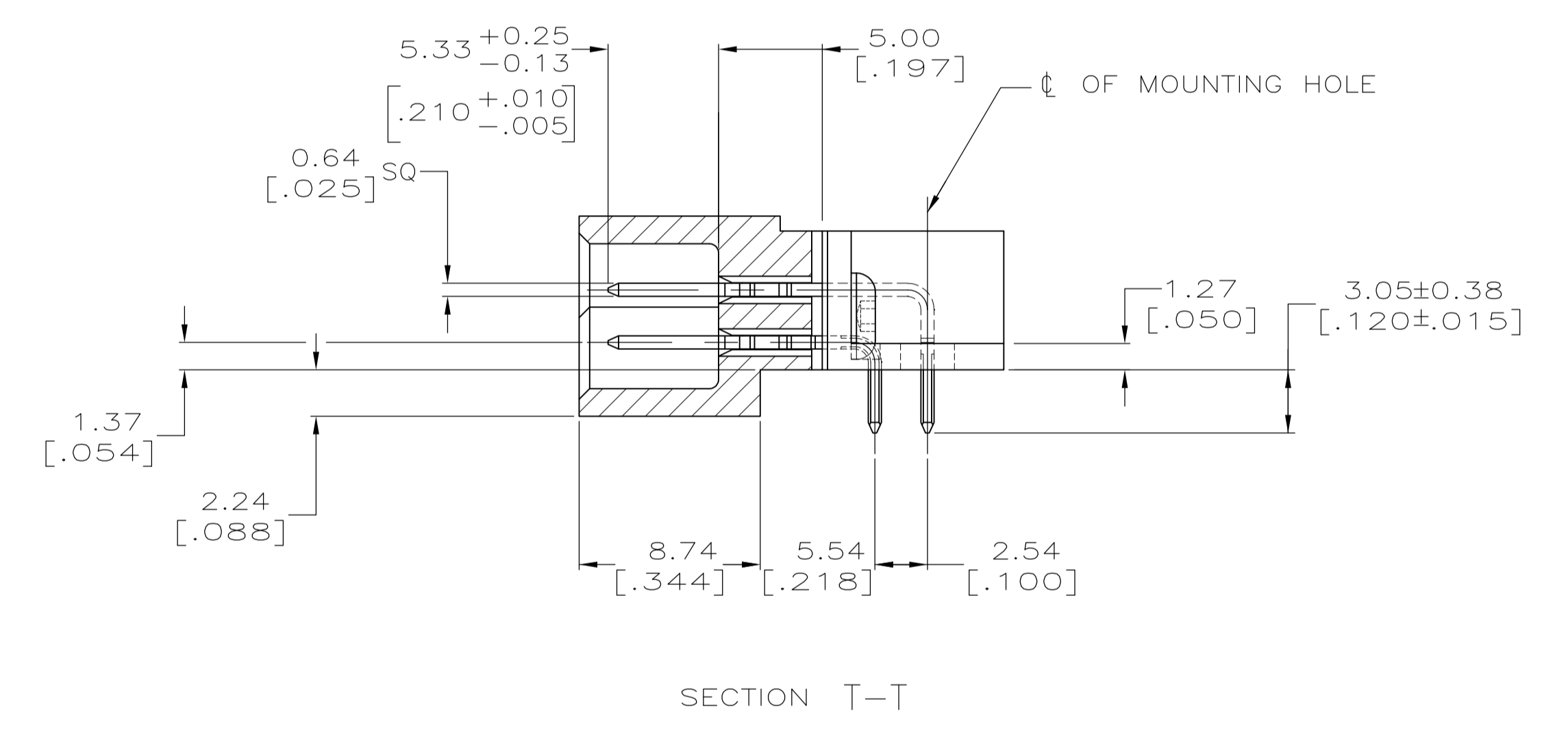
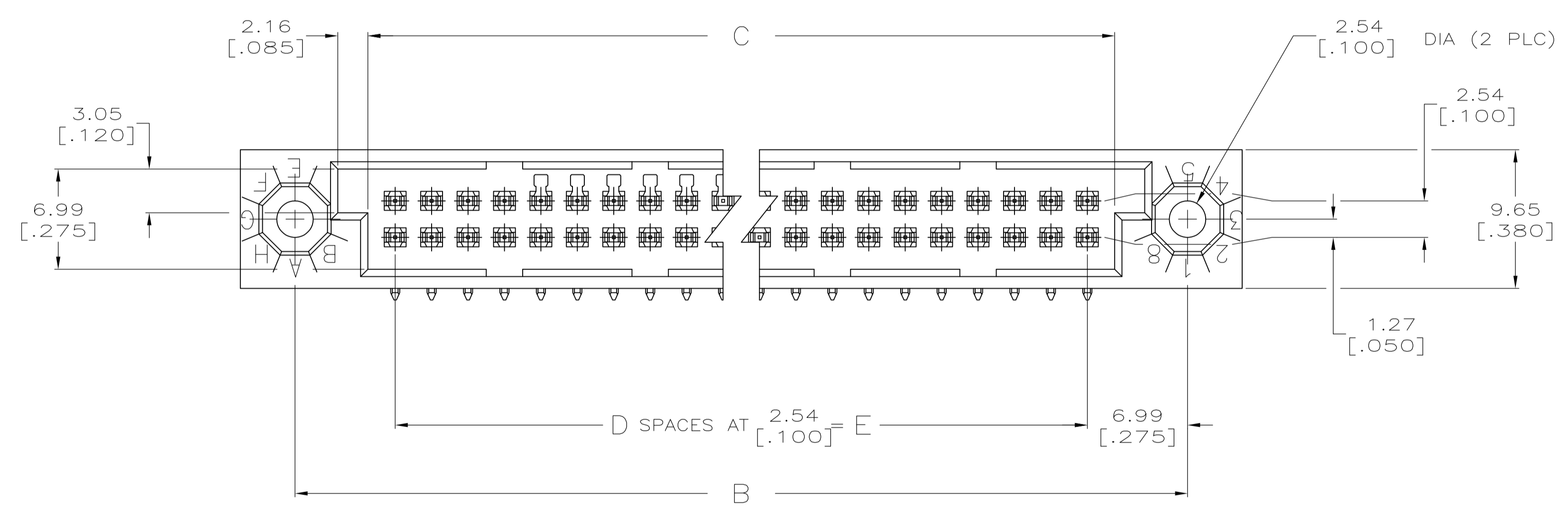
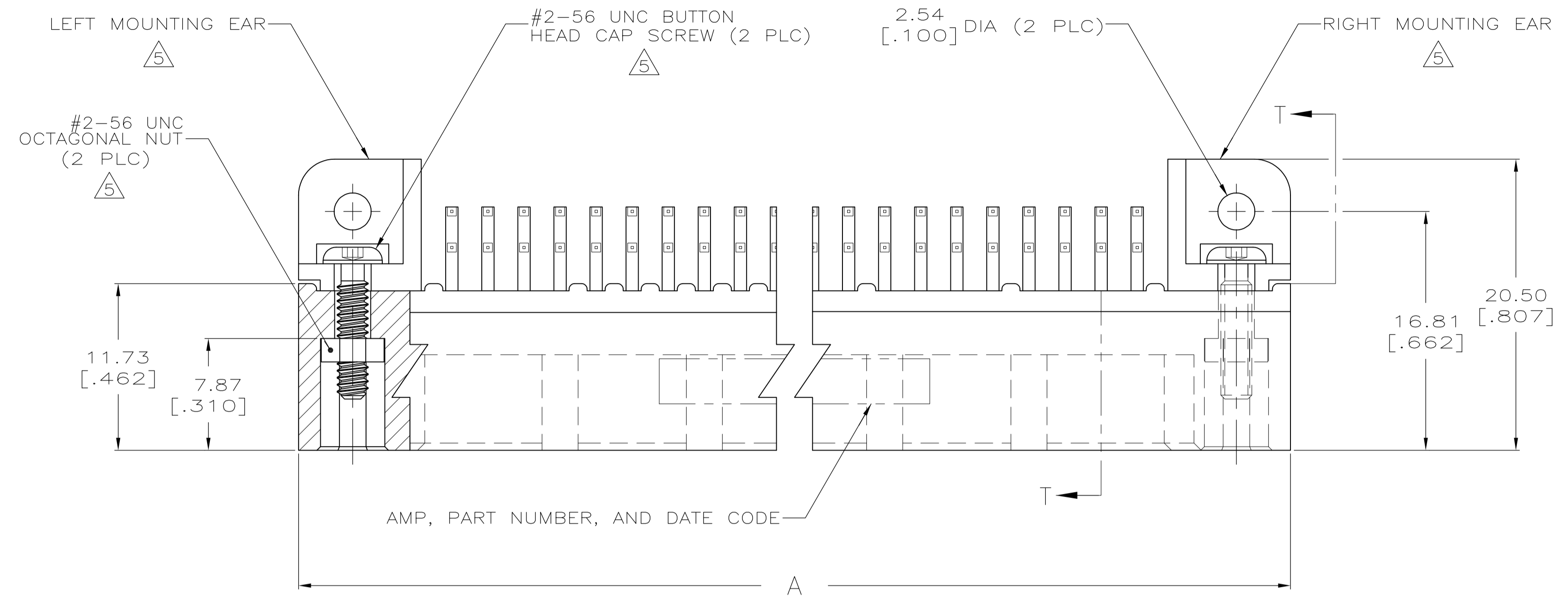

RECOMMENDED P.C. BOARD LAYOUT

THIS DRAWING IS A CONTROLLED DOCUMENT.		DIN R.K. SEIFRIED 05/18/90	TE Connectivity	
		CHK F. KIBLER 8-18-92		
DIMENSIONS: mm [INCHES]		TOLERANCES UNLESS OTHERWISE SPECIFIED:		NAME
0 PLC ± - 1 PLC ± - 2 PLC ± - 3 PLC ± 0.13 [.005] 4 PLC ± - ANGLES ± -		APVD		PRODUCT SPEC
FINISH 1 2 3 9		MATERIAL		APPLICATION SPEC
WEIGHT 0		SIZE A1		RESTRICTED TO
CUSTOMER DRAWING		DRAWING NO. 00779C=533295		SCALE 4:1 SHEET 1 OF 2 REV M

REVISIONS					
P	LTR	DESCRIPTION	DATE	DMN	APVD
-		SEE SHEET 1	-	-	-

- ① HOUSING MATERIAL: THERMOPLASTIC, COLOR-NATURAL.
- ② CONTACT MATERIAL: PHOSPHOR BRONZE.
- ③ FINISH:
MATING AREA: MEETS THE PERFORMANCE REQUIREMENTS OF PRODUCT SPECIFICATION 108-9063; BASED ON TELCORDIA DR-1217-CORE APPLICATIONS IN UNCONTROLLED ENVIRONMENTS.
SOLDER TAILS AREA: TIN-LEAD PLATED.
- ④ RIGHT ANGLE PIN RECOMMENDED P.C. BOARD HOLE SIZES ARE 0.94-1.09 [.037-.043]; RECOMMENDED PAD DIA IS 1.52 [.060].
- ⑤ MOUNTING EARS AND HARDWARE PURCHASED SEPARATELY, KIT PART NUMBER 533050-1.
- 6. DIMENSIONS IN BRACKETS ARE IN INCHES.
- ⑦ PART NUMBER IS OBSOLETE.
- ⑧ OBSOLETE PARTS: OBSOLETE CIS STREAMLINING PER D.RENAUD/D.SINISI
- ⑨ FINISH:
CONTACT FINISH: .00127-.00254 [.000050-.000100] NICKEL UNDERPLATE ALL OVER; .000762 [.000030] GOLD PLATE IN CONTACT AREA, TIN-LEAD PLATED POSTS.

①							1-533295-9
②							1-533295-8
③							1-533295-7
④							1-533295-6
⑤							1-533295-5
⑥	187.96 [7.400]	74	191.77 [7.550]	201.93 [7.950]	209.55 [8.250]	150	1-533295-4
⑦							1-533295-3
⑧							1-533295-2
⑨							1-533295-1
⑩							1-533295-0
⑪							533295-9
⑫							533295-8
⑬							533295-7
⑭							533295-6
⑮							533295-5
⑯	60.96 [2.400]	24	64.77 [2.550]	74.93 [2.950]	82.55 [3.250]	50	533295-4
⑰							533295-3
⑱	35.56 [1.400]	14	39.37 [1.550]	49.53 [1.950]	57.15 [2.250]	30	533295-2
⑲	22.86 [.900]	9	26.67 [1.050]	36.83 [1.450]	44.45 [1.750]	20	533295-1
	E	D	C	B	A	POSN	PART NUMBER

⑧ OBSOLETE

THIS DRAWING IS A CONTROLLED DOCUMENT.		DIN R. K. SEIFRIED 05/18/90		 TE Connectivity	
DIMENSIONS: mm [INCHES]		TOLERANCES UNLESS OTHERWISE SPECIFIED:		CHK F. KIBLER 8-18-92 APVD - NAME	
0 PLC ± - 1 PLC ± - 2 PLC ± - 3 PLC ± 0.13 [.005] 4 PLC ± - ANGLES ± -		PRODUCT SPEC - APPLICATION SPEC -		HDI, 2 ROW, RIGHT ANGLE PIN ASSEMBLY, WITH MOUNTING EARS, 3.05 [.120] LONG SOLDER TAILS	
MATERIAL ①②		FINISH ③④		SIZE CASE CODE DRAWING NO RESTRICTED TO WEIGHT 0 A1 00779 C=533295 -	
CUSTOMER DRAWING				SCALE 4:1 SHEET 2 OF 2 REV M	