

1595C Enclosure

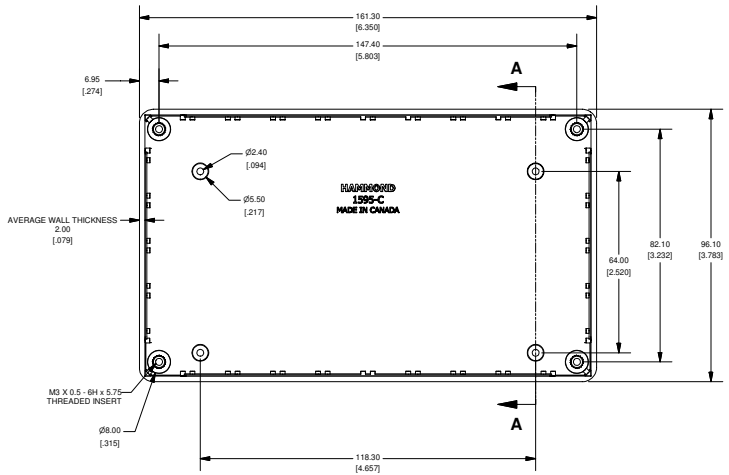

ENCLOSURE

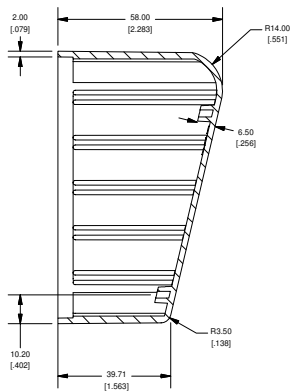

**SECTION A-A
SCALE 3 / 4**

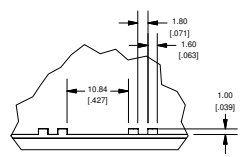

**DETAIL B
SCALE 1.50 : 1**

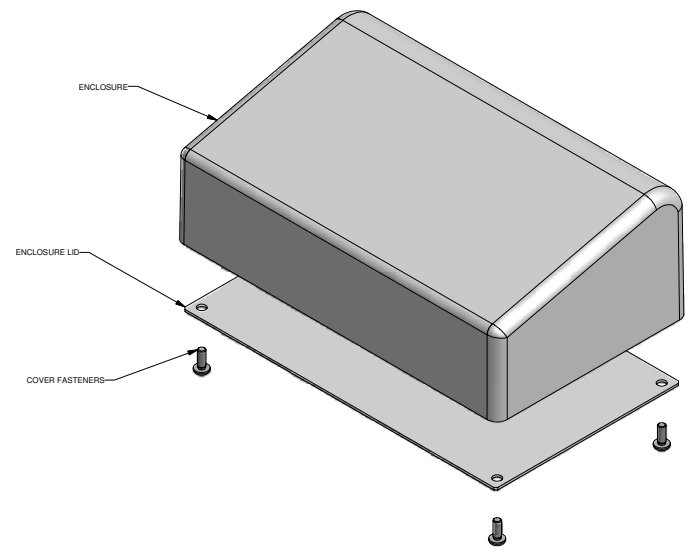

ENCLOSURE ASSEMBLY

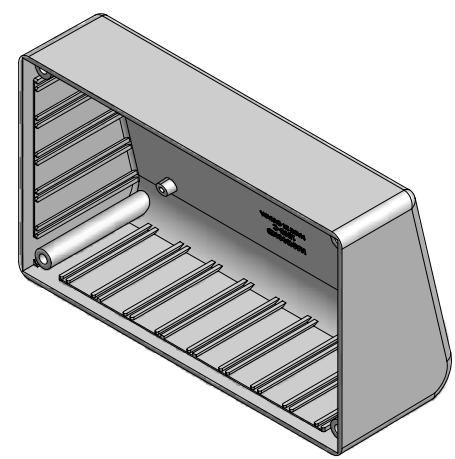

VIEW OF INSIDE ENCLOSURE

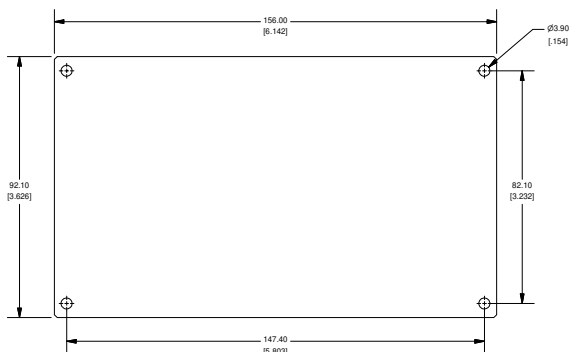

ENCLOSURE LID

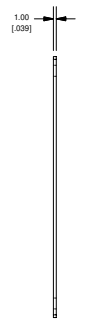

www.hammondmfg.com

PART NUMBERS		
1595C Enclosures		
Material	Colour	Part Number
ABS	Black	1595CBK
	Grey	1595CGY
Accessories		
	Description	Part Number
	Replacement Screws, machine, M3 - 0.5 x 8mm, Pack of 100,	1595MS100
	Replacement Internal Standoff Screws, #6 X .25" (6.4mm), Pack of 100	1598ATS100