



**ANATECH ELECTRONICS INC**  
RF & Microwave Filters & Products

## 31.5 MHz LC Band Pass Filter

Part Number: AE31.5B6357



### Electrical Specifications

**Center Frequency:** 31.5 MHz  
**1.0dB Passband:** 3-66 MHz  
**Insertion Loss:** 1.0dB Max.  
**Return Loss:** 10dB Min.  
**Rejection:**  $\geq 40\text{dB}$  @ 0-1 MHz  
**Rejection2:**  $\geq 40\text{dB}$  @ 85-300 MHz

### Mechanical

**Mounting Method:** Tapped Holes  
**Connector Type:** SMA(F)  
**Dimensions:** 2.38" X 1.0" x 1.0" .

### Environmental

**Operating Temperature:** -25°C to +70°C  
**Storage Temperature:** -40°C to +90°C  
**Shock:** 10 G. 11ms  
**Vibration:** 10 G. 5 to 200Hz

### Outline Drawing:

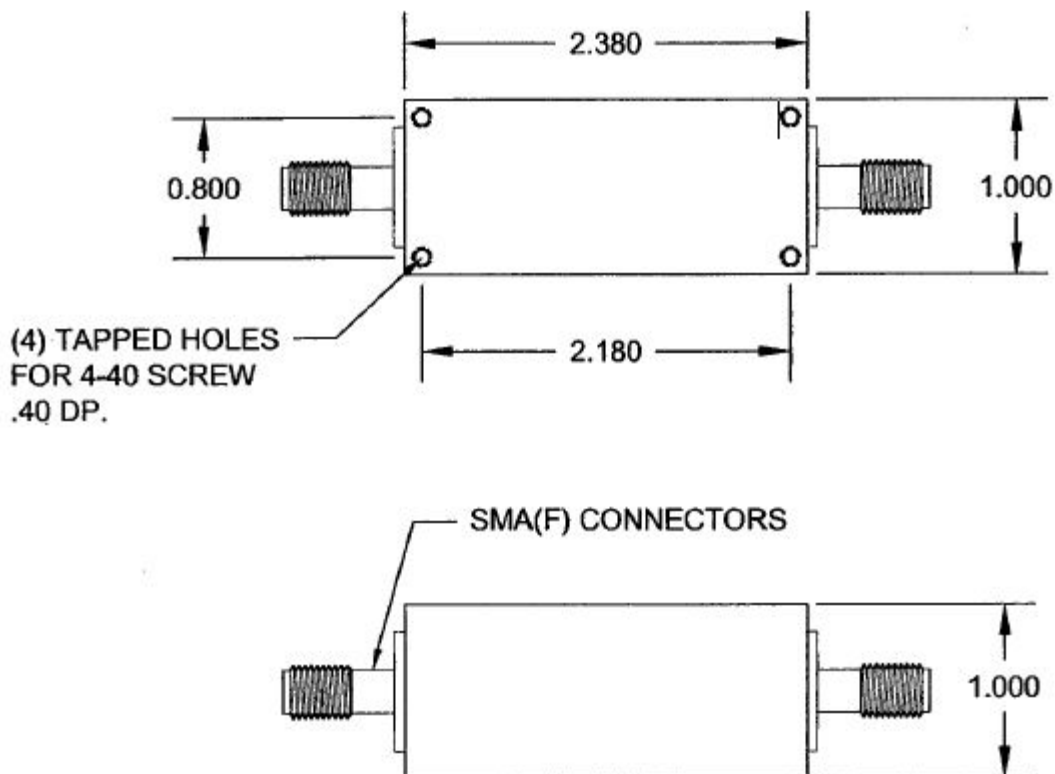



**Response Plot:**

