

# 3.2 x 1.6 x 0.5 (mm) WiFi Dual Band Chip Antenna (AA077)

## Engineering Specification

### 1. Product Number

H 2 U 8 4 W 1 H 1 S 0 3 0 0

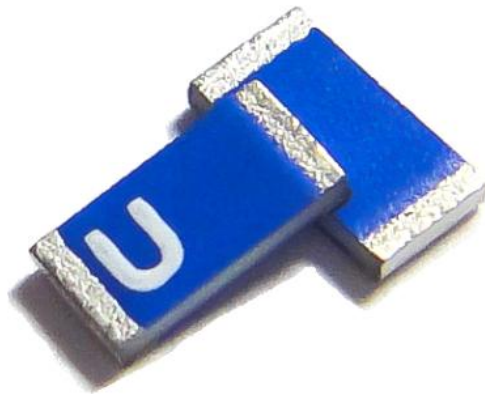

### 2. Features

- \*Stable and reliable performances in both 2.4 and 5 GHz bands
- \*Low profile and compact size
- \*RoHS 2.0 compliance
- \*SMT processes compatible
- \*AEC-Q200 compliant

### 3. Applications

- \*Wi-Fi CERTIFIED ac applications
- \*Wireless communication devices when IEEE802.11 a/b/g/n/ac functions are needed.
- \*IoT applications

### 4. Description

Unictron's AA077 ceramic chip antenna is designed for Wi-Fi CERTIFIED ac applications, covering both 2400~2500 MHz & 5150~5850 MHz frequency bands. Fabricated with proprietary design and processes, AA077 shows excellent performance and is fully compatible with SMT processes which can decrease the assembly cost and improve device's quality and consistency.



詠業科技股份有限公司  
Unictron Technologies Corporation  
Website: www.unictron.com

THIS DRAWINGS AND SPECIFICATIONS ARE THE PROPERTY OF UNICTRON TECHNOLOGIES CORPORATION AND SHALL NOT BE REPRODUCED OR USED AS THE BASIS FOR THE MANUFACTURE OR SALE OF APPARATUS OR DEVICES WITHOUT PERMISSION

Prepared by : Jane

Designed by : Peter

Checked by : Mike

Approved by : Herbert

TITLE : 3.2 x 1.6 x 0.5 (mm) WiFi Dual Band Chip Antenna (AA077) Engineering Specification

DOCUMENT NO.

H2U84W1H1S0300

REV.

L

## 5. Layout Guide & Electrical Specifications

### 5-1. Layout Guide (unit : mm)

Solder Land Pattern:

The solder land pattern (gold marking areas) is shown below. Recommendation on matching circuit will be provided according to customer's installation conditions.

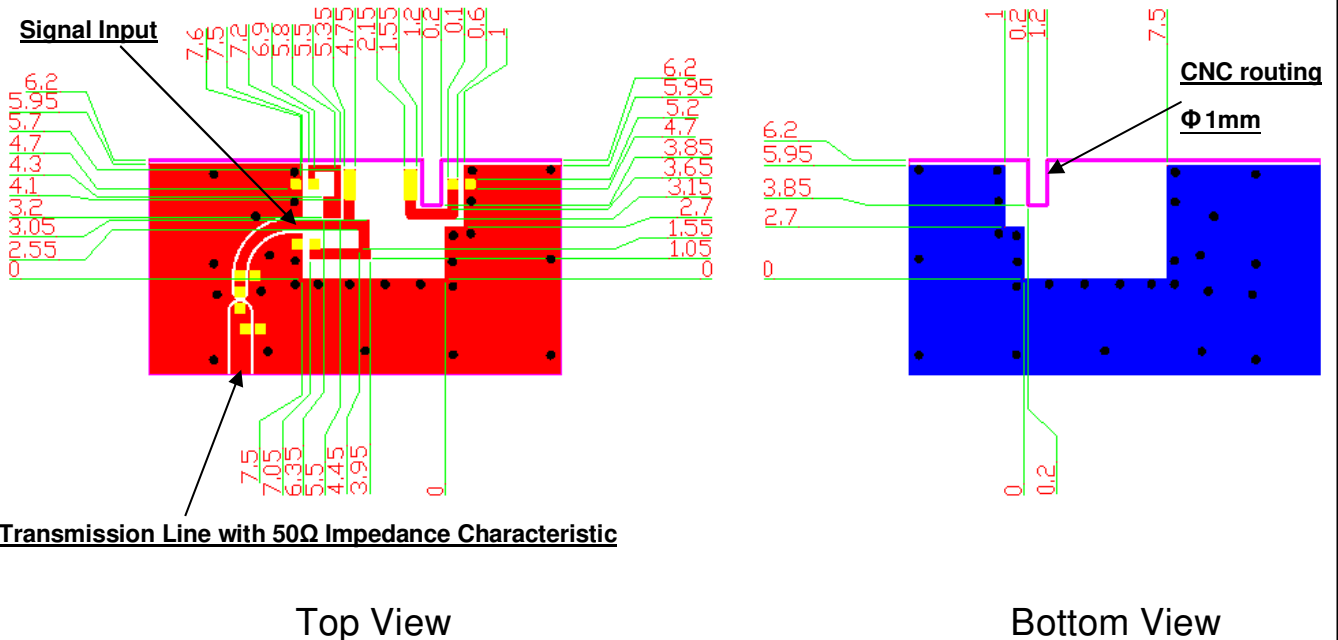

### 5-2. Electrical Specifications (Evaluation Board Dimensions: 80 x 40 mm<sup>2</sup>)

#### 5-2-1. Electrical Table

Characteristics	Specifications	
Outline Dimension (mm)	3.2 x 1.6 x 0.5	
Working Frequency (MHz)	2400 ~ 2500	5150 ~ 5850
Peak Gain (dBi) (typical)**	1.4	2.3
Radiation Efficiency (%) (typical)**	76	67
VSWR (@ center frequency)*	< 2 : 1	< 2 : 1
Characteristic Impedance (Ω)	50	
Polarization	Linear Polarization	

\*Center frequency means the frequency with the lowest value in return loss of the chip antenna on the evaluation board.

\*\*A typical value is for reference only, not guaranteed.

Unictron  
Technologies Corp.  
2020-07-01  
Document  
Control Center



詠業科技股份有限公司  
Unictron Technologies Corporation  
Website: www.unictron.com

THIS DRAWINGS AND SPECIFICATIONS ARE THE PROPERTY OF UNICTRON TECHNOLOGIES CORPORATION AND SHALL NOT BE REPRODUCED OR USED AS THE BASIS FOR THE MANUFACTURE OR SALE OF APPARATUS OR DEVICES WITHOUT PERMISSION

Prepared by : Jane

Designed by : Peter

Checked by : Mike

Approved by : Herbert

TITLE : 3.2 x 1.6 x 0.5 (mm) WiFi Dual Band Chip  
Antenna (AA077) Engineering Specification

DOCUMENT  
NO.

H2U84W1H1S0300

REV.  
L

## 5-2-2. Frequency vs. V.S.W.R. and Total Radiation Gain

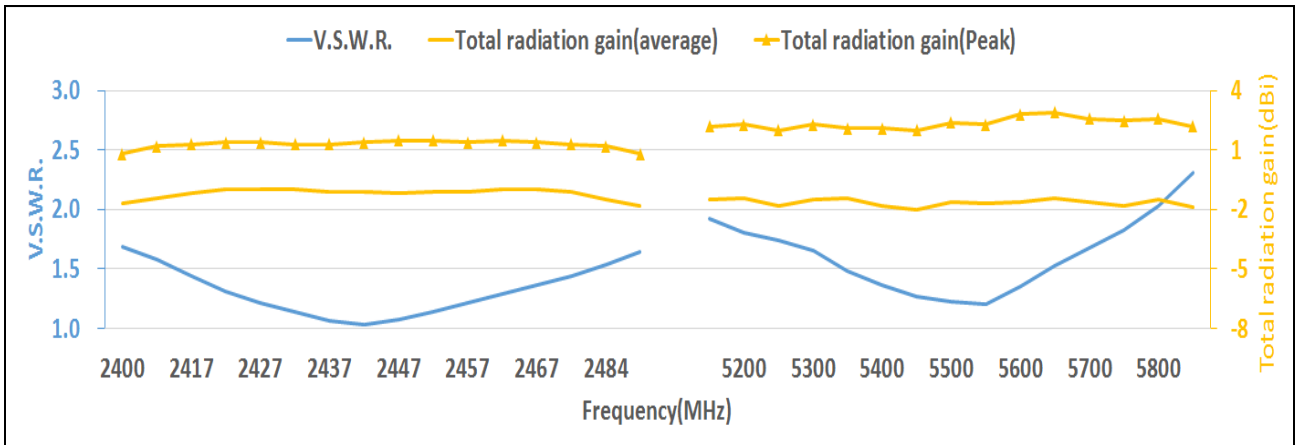

## 6. Outline Dimensions of Antenna & Evaluation Board (unit: mm)

### 6-1. Antenna Dimensions

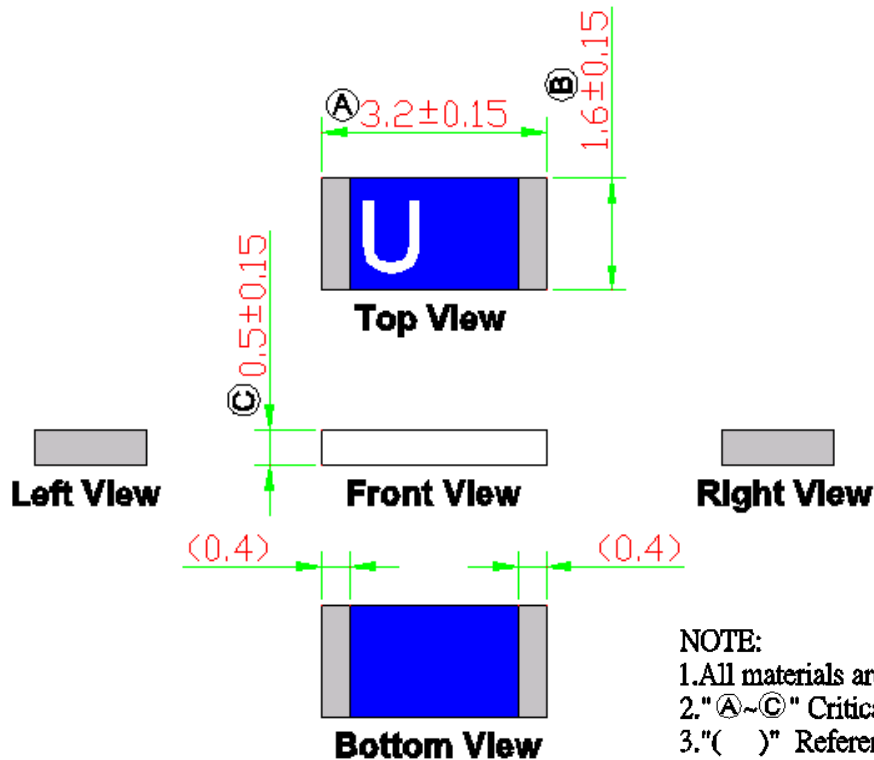

NOTE:  
 1. All materials are RoHS compliant.  
 2. "A~C" Critical Dimensions.  
 3. "( )" Reference Dimensions.



詠業科技股份有限公司  
 Unictron Technologies Corporation  
 Website: www.unictron.com

THIS DRAWINGS AND SPECIFICATIONS ARE THE PROPERTY OF UNICTRON TECHNOLOGIES CORPORATION AND SHALL NOT BE REPRODUCED OR USED AS THE BASIS FOR THE MANUFACTURE OR SALE OF APPARATUS OR DEVICES WITHOUT PERMISSION

Prepared by : Jane

Designed by : Peter

Checked by : Mike

Approved by : Herbert

TITLE : 3.2 x 1.6 x 0.5 (mm) WiFi Dual Band Chip Antenna (AA077) Engineering Specification

DOCUMENT NO.

H2U84W1H1S0300

REV. L

## PIN Definition

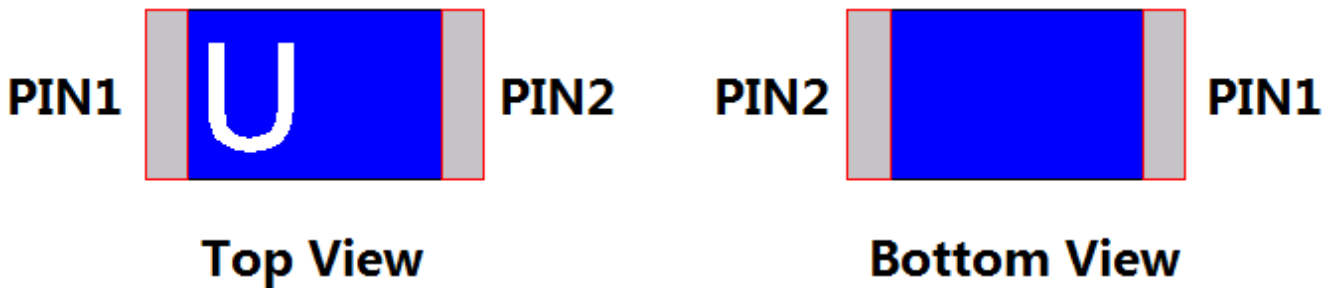

PIN	1	2
Soldering PAD	Signal	Tuning / Ground

### 6-2. Evaluation Board with Antenna

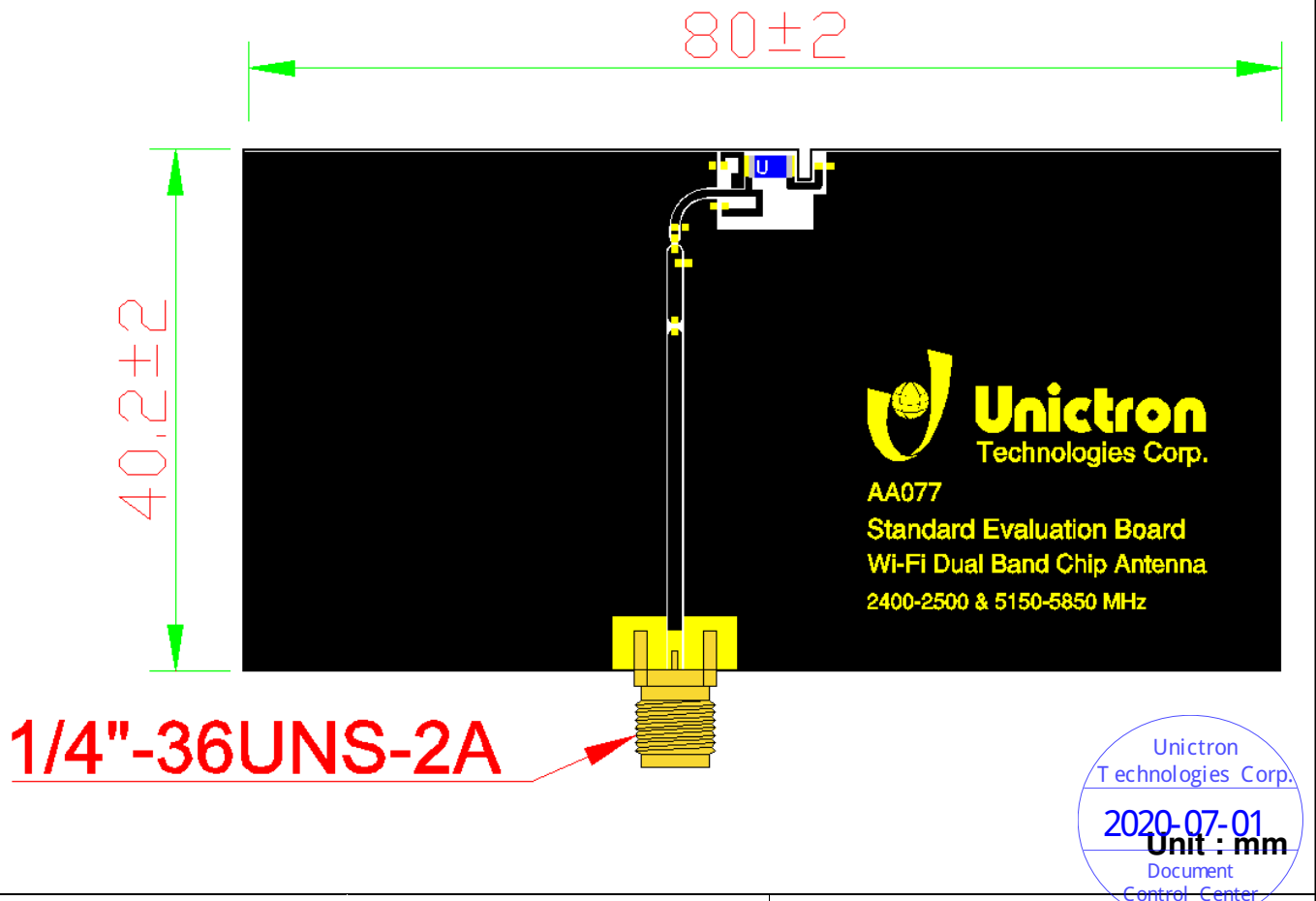

**詠業科技股份有限公司**  
 Unicon Technologies Corporation  
 Website: www.unicon.com

THIS DRAWINGS AND SPECIFICATIONS ARE THE  
 PROPERTY OF UNICON TECHNOLOGIES  
 CORPORATION AND SHALL NOT BE REPRODUCED  
 OR USED AS THE BASIS FOR THE MANUFACTURE OR  
 SALE OF APPARATUS OR DEVICES WITHOUT  
 PERMISSION

Prepared by : **Jane**      Designed by : **Peter**      Checked by : **Mike**      Approved by : **Herbert**

<b>TITLE</b> : 3.2 x 1.6 x 0.5 (mm) WiFi Dual Band Chip Antenna (AA077) Engineering Specification	<b>DOCUMENT NO.</b>	<b>H2U84W1H1S0300</b>	<b>REV.</b> L
---	---------------------	-----------------------	------------------

## 7. 3D Radiation Gain Pattern (with 80 x 40 mm<sup>2</sup> Evaluation Board)

### 7-1. 2400~2500 MHz Band

3D Radiation Gain Pattern @ 2442 MHz (unit: dBi)

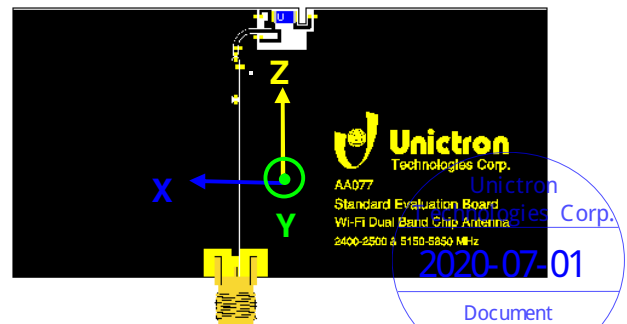
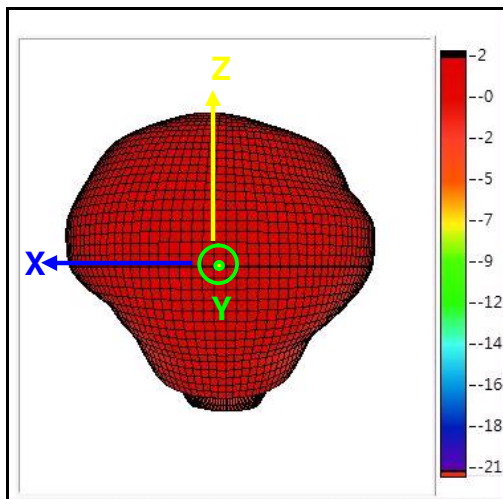
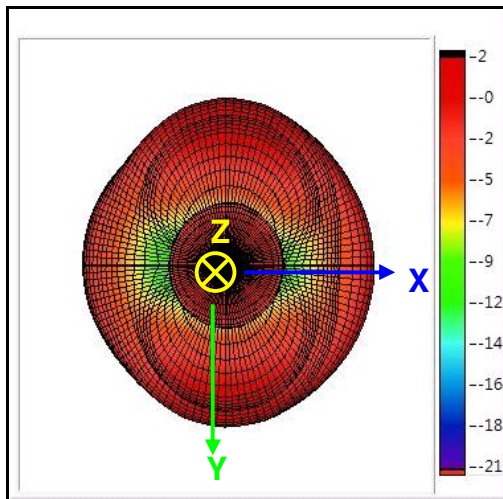
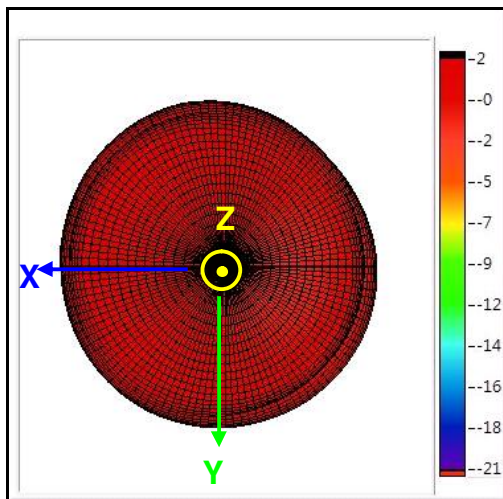

詠業科技股份有限公司  
Unictron Technologies Corporation  
Website: www.unictron.com

THIS DRAWINGS AND SPECIFICATIONS ARE THE PROPERTY OF UNICTRON TECHNOLOGIES CORPORATION AND SHALL NOT BE REPRODUCED OR USED AS THE BASIS FOR THE MANUFACTURE OR SALE OF APPARATUS OR DEVICES WITHOUT PERMISSION

Prepared by : Jane

Designed by : Peter

Checked by : Mike

Approved by : Herbert

TITLE : 3.2 x 1.6 x 0.5 (mm) WiFi Dual Band Chip Antenna (AA077) Engineering Specification

DOCUMENT NO.

H2U84W1H1S0300

REV.

L

## 7-2. 5150~5850 MHz Band

### 7-2-1. 3D Radiation Gain Pattern @ 5150 MHz (unit: dBi)

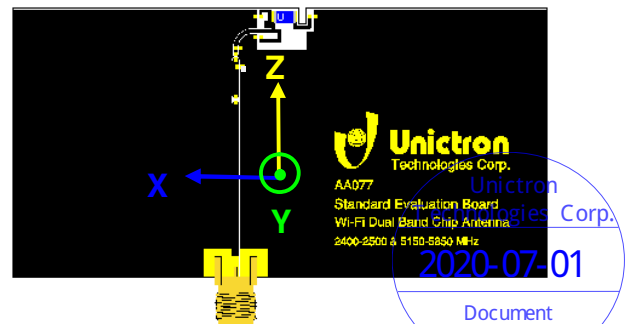
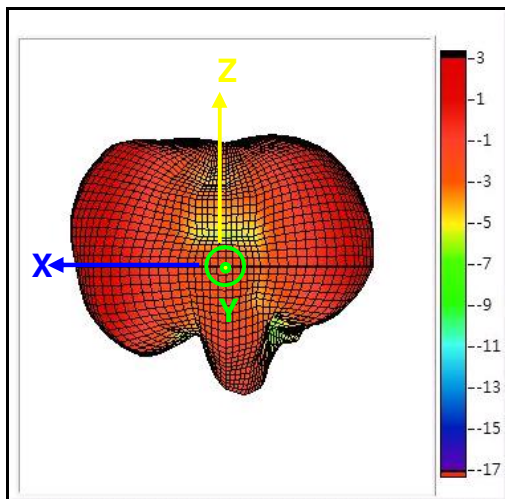
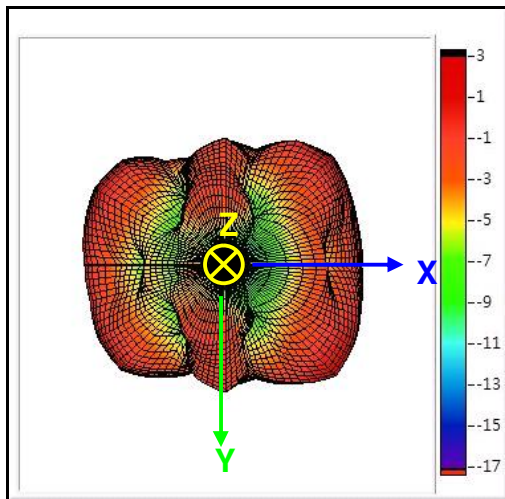
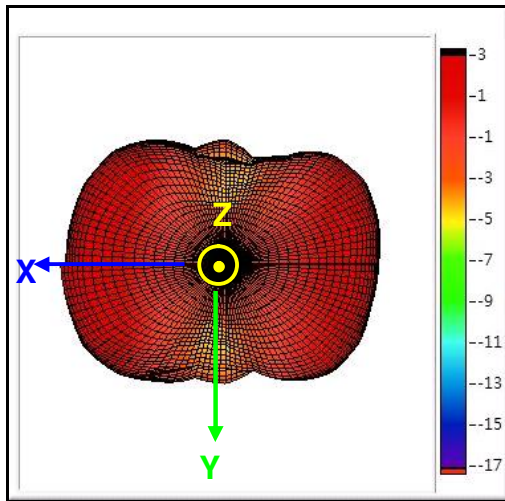

詠業科技股份有限公司  
Unictron Technologies Corporation  
Website: www.unictron.com

THIS DRAWINGS AND SPECIFICATIONS ARE THE PROPERTY OF UNICTRON TECHNOLOGIES CORPORATION AND SHALL NOT BE REPRODUCED OR USED AS THE BASIS FOR THE MANUFACTURE OR SALE OF APPARATUS OR DEVICES WITHOUT PERMISSION

Prepared by : Jane

Designed by : Peter

Checked by : Mike

Approved by : Herbert

TITLE : 3.2 x 1.6 x 0.5 (mm) WiFi Dual Band Chip Antenna (AA077) Engineering Specification

DOCUMENT NO.

H2U84W1H1S0300

REV.

L

7-2-2. 3D Radiation Gain Pattern @ 5550 MHz (unit: dBi)

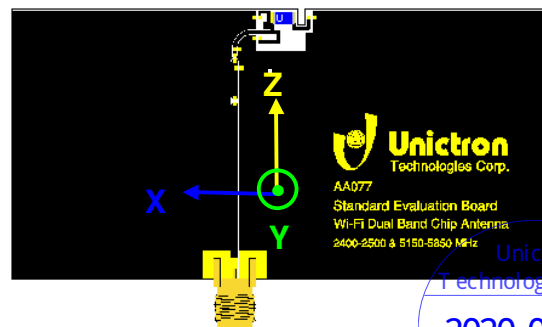
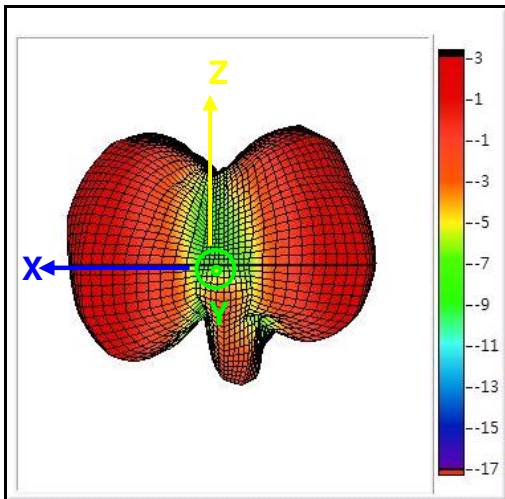
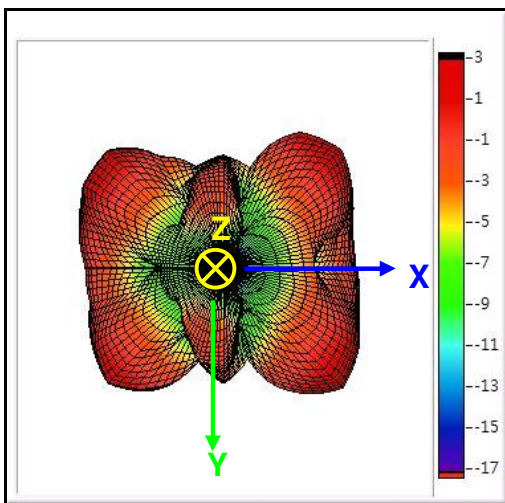
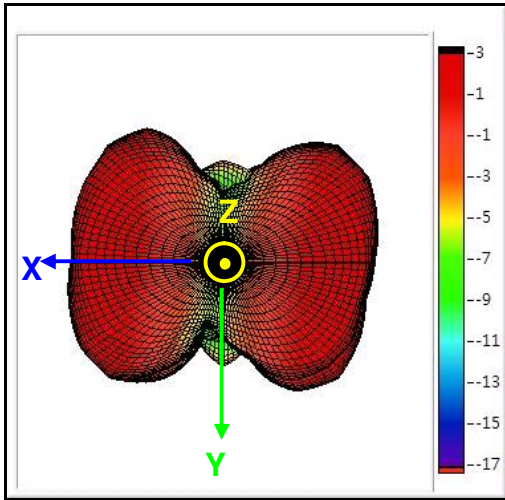

Unictron Technologies Corp.  
2020-07-01  
Document Control Center



詠業科技股份有限公司  
Unictron Technologies Corporation  
Website: www.unictron.com

THIS DRAWINGS AND SPECIFICATIONS ARE THE PROPERTY OF UNICTRON TECHNOLOGIES CORPORATION AND SHALL NOT BE REPRODUCED OR USED AS THE BASIS FOR THE MANUFACTURE OR SALE OF APPARATUS OR DEVICES WITHOUT PERMISSION

Prepared by : Jane

Designed by : Peter

Checked by : Mike

Approved by : Herbert

TITLE : 3.2 x 1.6 x 0.5 (mm) WiFi Dual Band Chip Antenna (AA077) Engineering Specification

DOCUMENT NO.

H2U84W1H1S0300

REV.

L

7-2-3. 3D Radiation Gain Pattern @ 5850 MHz (unit: dBi)

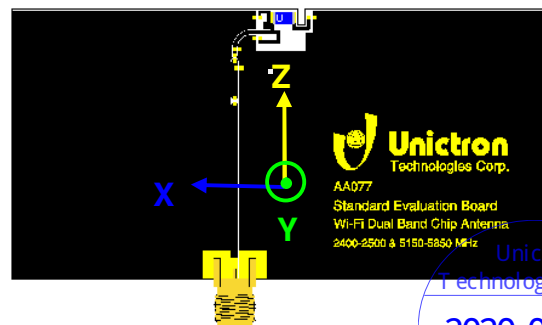
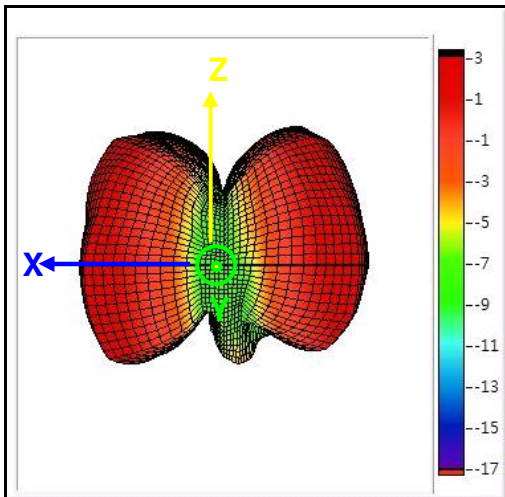
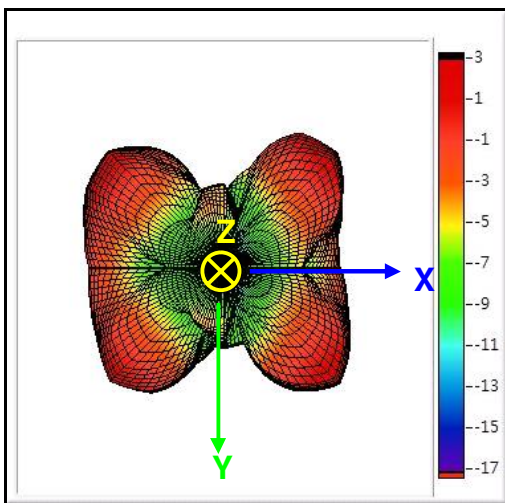
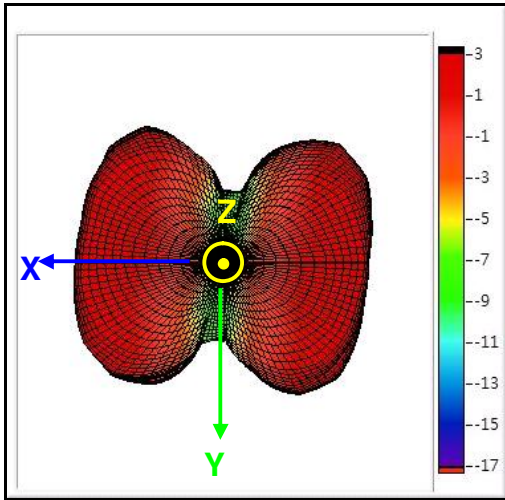

Unicon Technologies Corp.  
2020-07-01  
Document Control Center



詠業科技股份有限公司  
Unicon Technologies Corporation  
Website: www.unicon.com

THIS DRAWINGS AND SPECIFICATIONS ARE THE PROPERTY OF UNICTRON TECHNOLOGIES CORPORATION AND SHALL NOT BE REPRODUCED OR USED AS THE BASIS FOR THE MANUFACTURE OR SALE OF APPARATUS OR DEVICES WITHOUT PERMISSION

Prepared by : Jane

Designed by : Peter

Checked by : Mike

Approved by : Herbert

TITLE : 3.2 x 1.6 x 0.5 (mm) WiFi Dual Band Chip Antenna (AA077) Engineering Specification

DOCUMENT NO.

H2U84W1H1S0300

REV.

L



## 8. Frequency tuning and Matching circuit

8-1. Chip antenna tuning scenario :

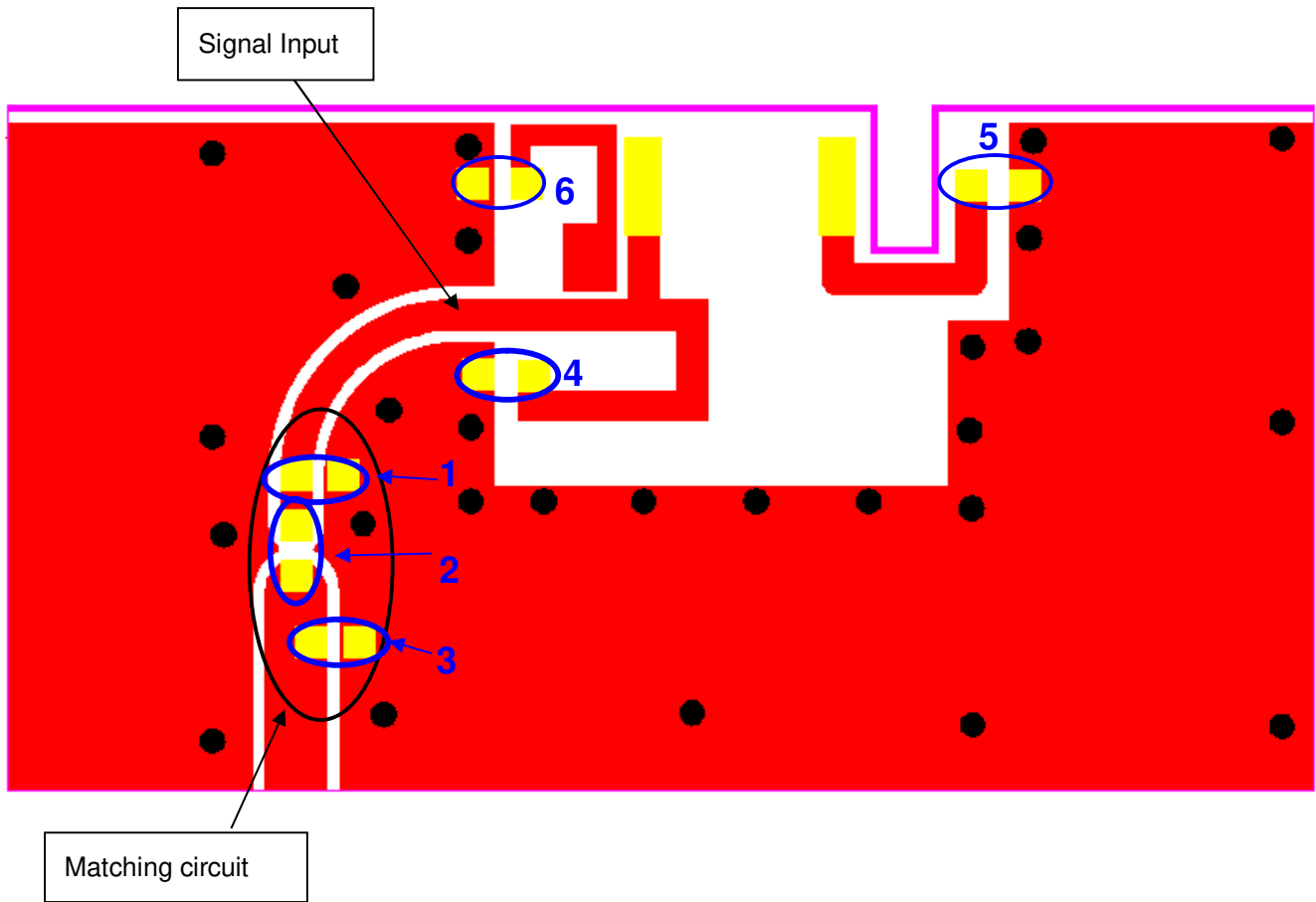

詠業科技股份有限公司  
Unictron Technologies Corporation  
Website: www.unictron.com

THIS DRAWINGS AND SPECIFICATIONS ARE THE PROPERTY OF UNICTRON TECHNOLOGIES CORPORATION AND SHALL NOT BE REPRODUCED OR USED AS THE BASIS FOR THE MANUFACTURE OR SALE OF APPARATUS OR DEVICES WITHOUT PERMISSION

Prepared by : Jane

Designed by : Peter

Checked by : Mike

Approved by : Herbert

TITLE : 3.2 x 1.6 x 0.5 (mm) WiFi Dual Band Chip Antenna (AA077) Engineering Specification

DOCUMENT NO.

H2U84W1H1S0300

REV.

L

## 8-2. Matching circuit :

With the following recommended values of matching and tuning components, the center frequencies will be about 2442 MHz for lower band & 5500 MHz for higher band at our standard 80x40 mm<sup>2</sup> evaluation board. However, these are typical reference values which may need to be changed when circuit boards or part vendors are different.

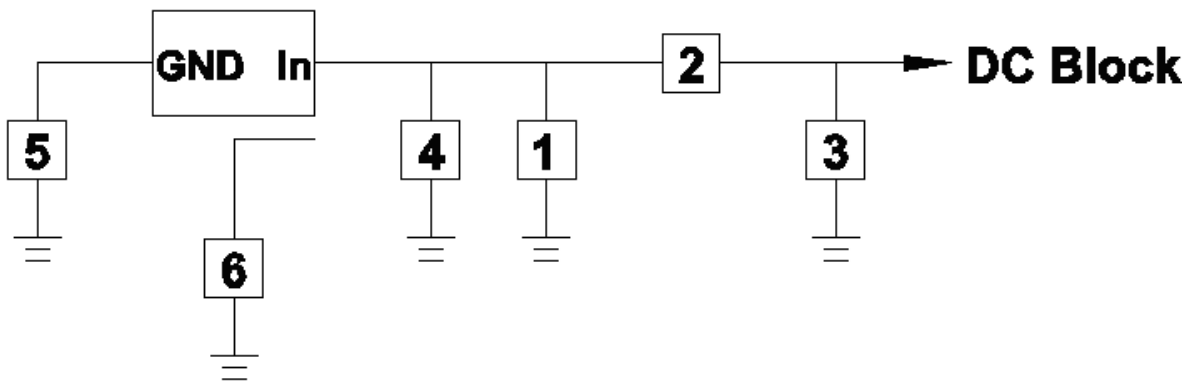

System Matching Circuit Component			
Location	Description	Vendor	Tolerance
1	N/A		
2	0Ω, (0402)		
3	0.1 pF, (0402)	MURATA	±0.05 pF
4	12 pF, (0402)	MURATA	±5%
5 Fine tuning element	1 pF, (0402)	MURATA	±0.05 pF
6 Fine tuning element	0.8 pF, (0402)	MURATA	±0.05 pF



詠業科技股份有限公司  
Unictron Technologies Corporation  
Website: www.unictron.com

THIS DRAWINGS AND SPECIFICATIONS ARE THE PROPERTY OF UNICTRON TECHNOLOGIES CORPORATION AND SHALL NOT BE REPRODUCED OR USED AS THE BASIS FOR THE MANUFACTURE OR SALE OF APPARATUS OR DEVICES WITHOUT PERMISSION

Prepared by : Jane

Designed by : Peter

Checked by : Mike

Approved by : Herbert

TITLE : 3.2 x 1.6 x 0.5 (mm) WiFi Dual Band Chip  
Antenna (AA077) Engineering Specification

DOCUMENT  
NO.

H2U84W1H1S0300

REV.  
L

### 8-3. Reference for frequency tuning element 5 (2400~2500 MHz Band)

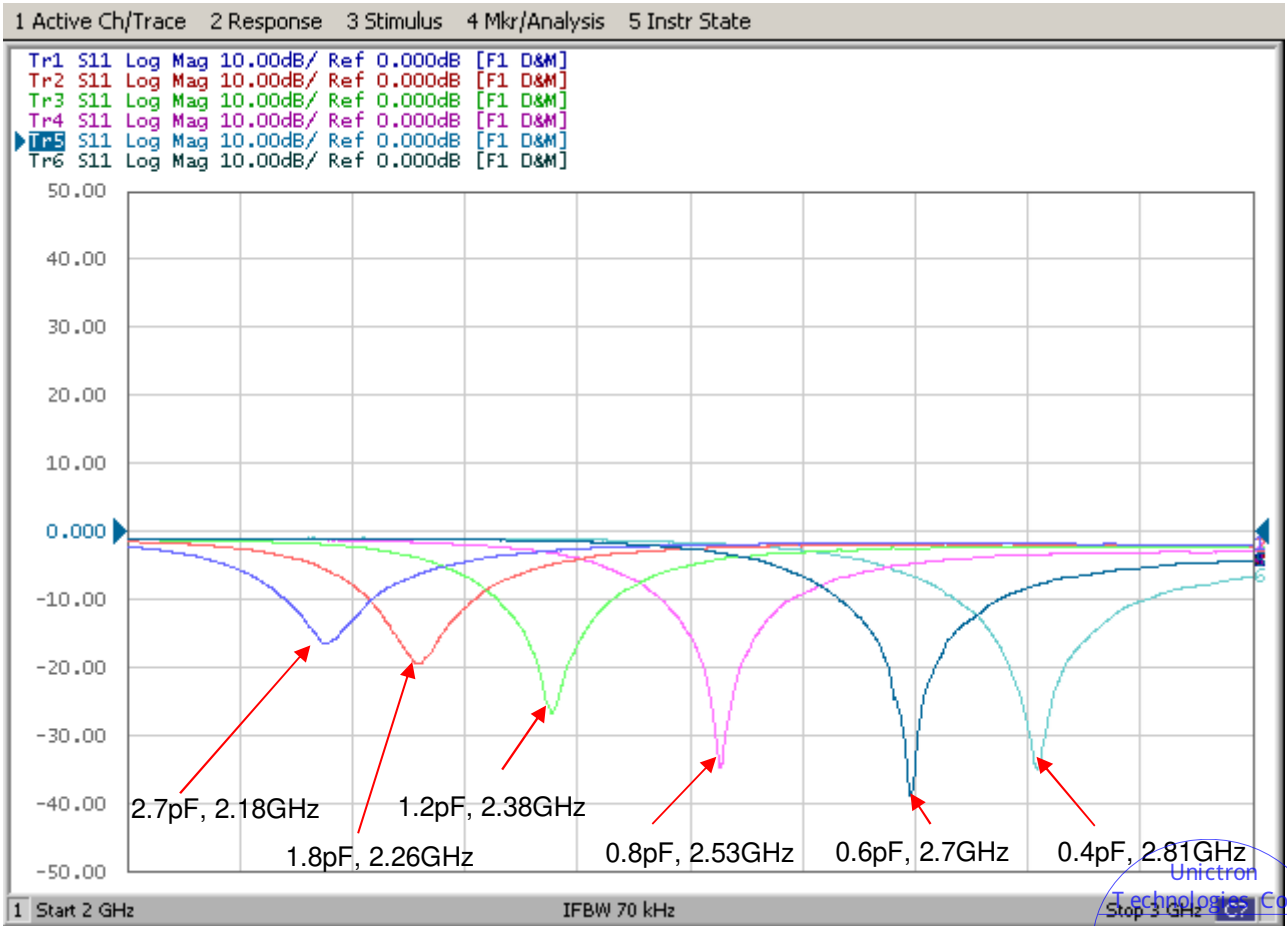
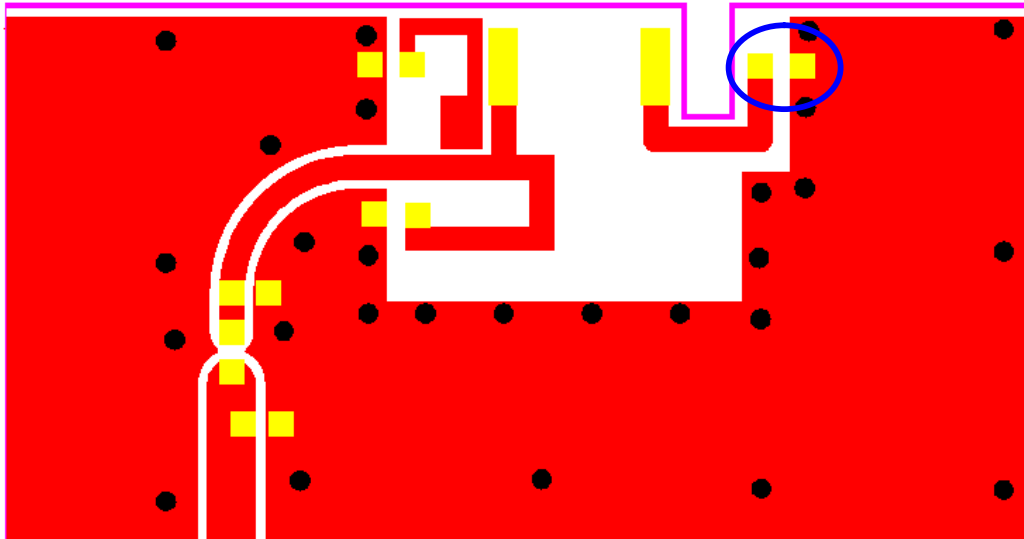

Unictron Technologies Corp.  
 2020-07-01  
 Document Control Center



詠業科技股份有限公司  
 Unictron Technologies Corporation  
 Website: www.unictron.com

THIS DRAWINGS AND SPECIFICATIONS ARE THE PROPERTY OF UNICTRON TECHNOLOGIES CORPORATION AND SHALL NOT BE REPRODUCED OR USED AS THE BASIS FOR THE MANUFACTURE OR SALE OF APPARATUS OR DEVICES WITHOUT PERMISSION

Prepared by : Jane      Designed by : Peter      Checked by : Mike      Approved by : Herbert

TITLE : 3.2 x 1.6 x 0.5 (mm) WiFi Dual Band Chip Antenna (AA077) Engineering Specification	DOCUMENT NO.	H2U84W1H1S0300	REV.
			L

### 8-4. Reference for frequency tuning element 6 (5150~5850 MHz Band)

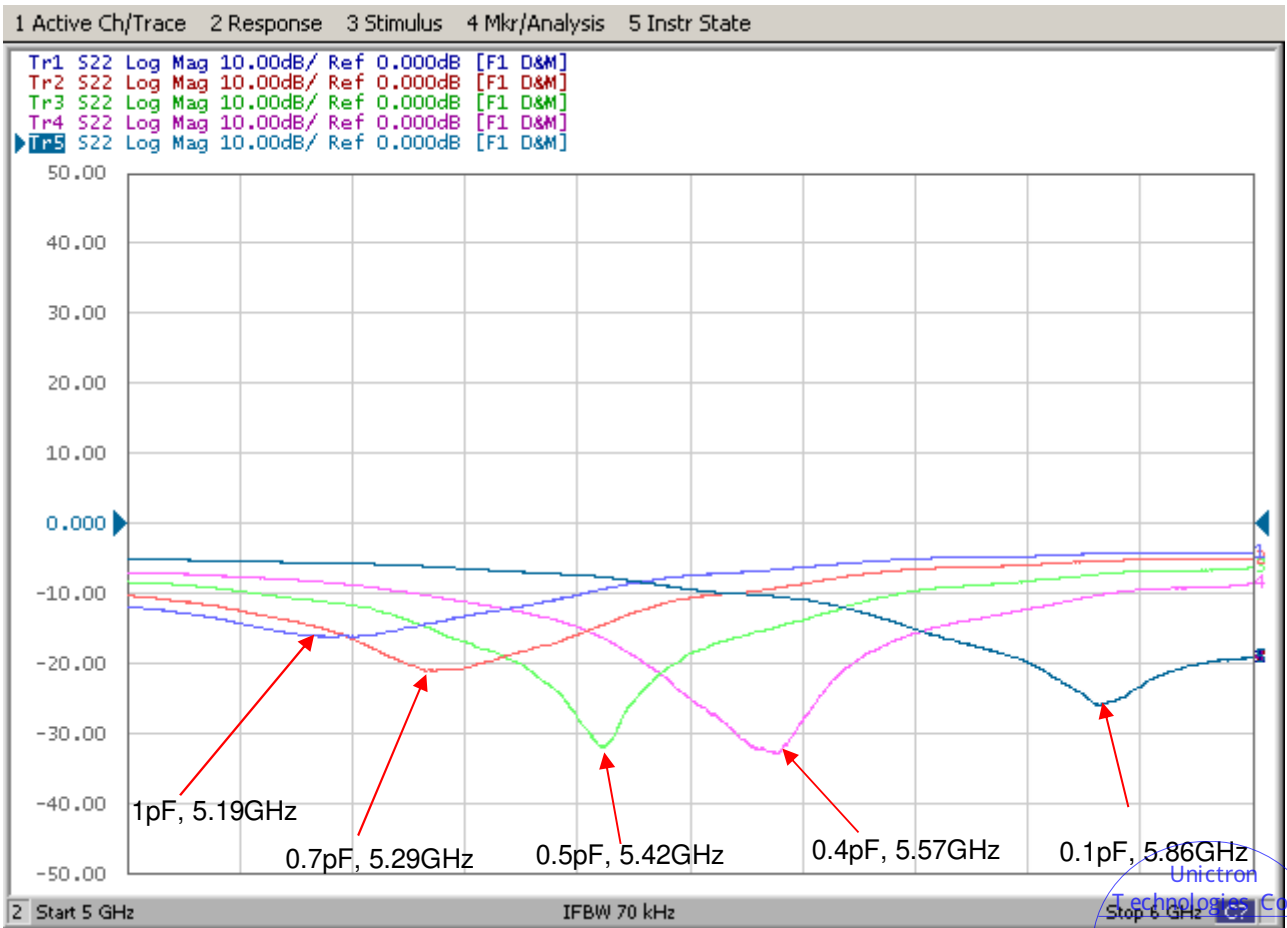
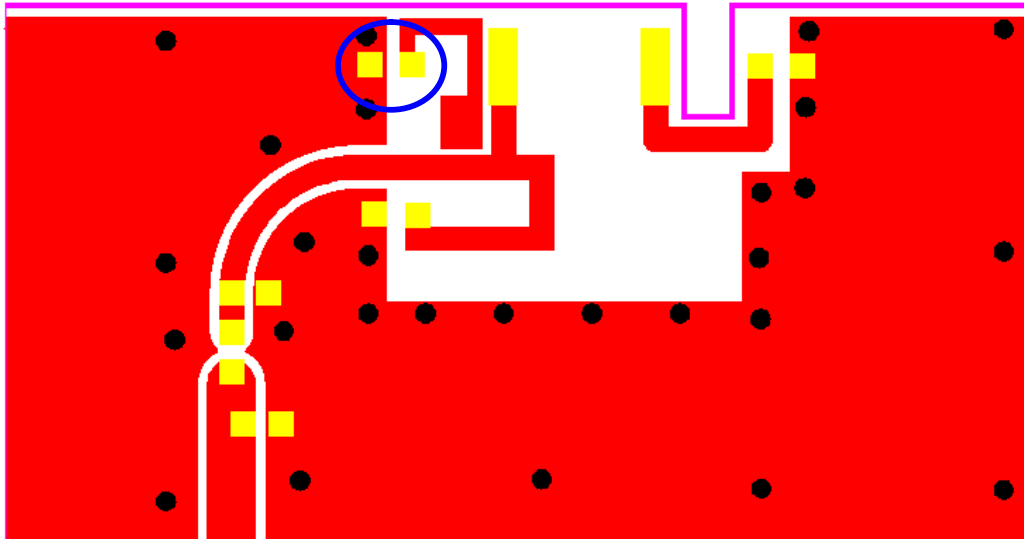

Unictron Technologies Corp.  
 2020-07-01  
 Document Control Center



詠業科技股份有限公司  
 Unictron Technologies Corporation  
 Website: www.unictron.com

THIS DRAWINGS AND SPECIFICATIONS ARE THE PROPERTY OF UNICTRON TECHNOLOGIES CORPORATION AND SHALL NOT BE REPRODUCED OR USED AS THE BASIS FOR THE MANUFACTURE OR SALE OF APPARATUS OR DEVICES WITHOUT PERMISSION

Prepared by : Jane      Designed by : Peter      Checked by : Mike      Approved by : Herbert

TITLE : 3.2 x 1.6 x 0.5 (mm) WiFi Dual Band Chip Antenna (AA077) Engineering Specification	DOCUMENT NO.	H2U84W1H1S0300	REV.
			L

## 9. Soldering Conditions

Typical Soldering Profile for Lead-free Process

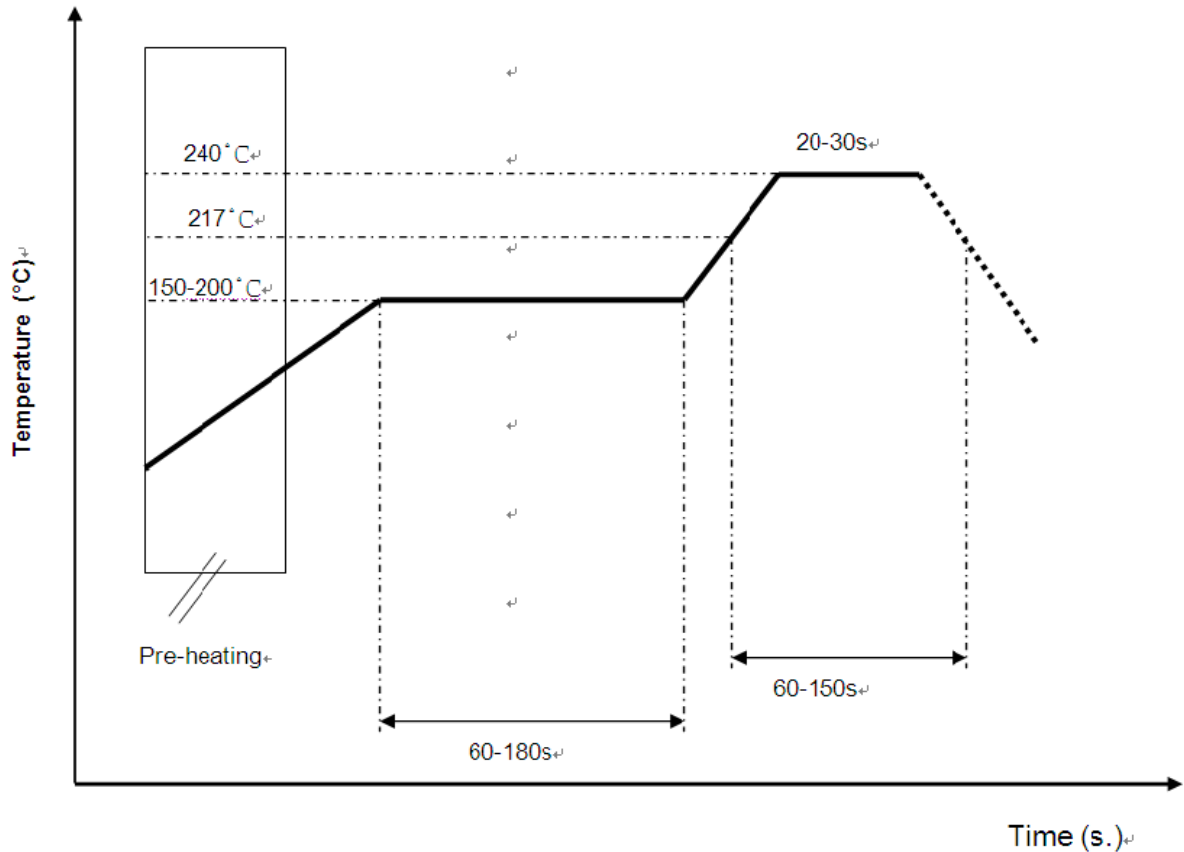

\*Recommended solder paste alloy: SAC305 (Sn96.5 /Ag3 /Cu0.5) Lead Free solder paste

## 10. Reminders for users of Unictron's AA077 ceramic chip antennas

- 10-1. This chip antenna is made of ceramic materials which are relatively more rigid and brittle compared to printed circuit board materials. Bending of circuit board at the locations where chip antenna is mounted may cause the cracking of solder joints or antenna itself.
- 10-2. Punching/cutting of the break-off tab of PCB panel may cause severe bending of the circuit board which may result in cracking of solder joints or chip antenna itself. Therefore break-off tab shall be located away from the installation site of chip antenna.
- 10-3. Be cautious when ultrasonic welding process needs to be used near the locations where chip antennas are installed. Strong ultrasonic vibration may cause the cracking of chip antenna solder joints.

Unictron  
Technologies Corp.  
2020-07-01  
Document  
Control Center



詠業科技股份有限公司  
Unictron Technologies Corporation  
Website: www.unictron.com

THIS DRAWINGS AND SPECIFICATIONS ARE THE PROPERTY OF UNICTRON TECHNOLOGIES CORPORATION AND SHALL NOT BE REPRODUCED OR USED AS THE BASIS FOR THE MANUFACTURE OR SALE OF APPARATUS OR DEVICES WITHOUT PERMISSION

Prepared by : Jane

Designed by : Peter

Checked by : Mike

Approved by : Herbert

TITLE : 3.2 x 1.6 x 0.5 (mm) WiFi Dual Band Chip Antenna (AA077) Engineering Specification

DOCUMENT NO.

H2U84W1H1S0300

REV.  
L

# 11. Packing

- (1) Quantity/Reel: 5000 pcs/Reel
- (2) Plastic tape: Black conductive polystyrene

a. Tape Drawing

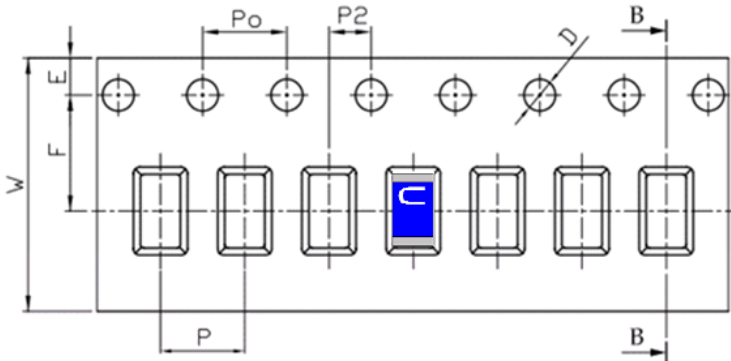

b. Tape Dimensions (unit: mm)

Feature	Specifications	Tolerances
W	12.00	±0.30
P	4.00	±0.10
E	1.75	±0.10
F	5.50	±0.10
P2	2.00	±0.10
D	1.50	+0.10 -0.00
P0	4.00	±0.10
10P0	40.00	±0.20

c. Reel Drawing

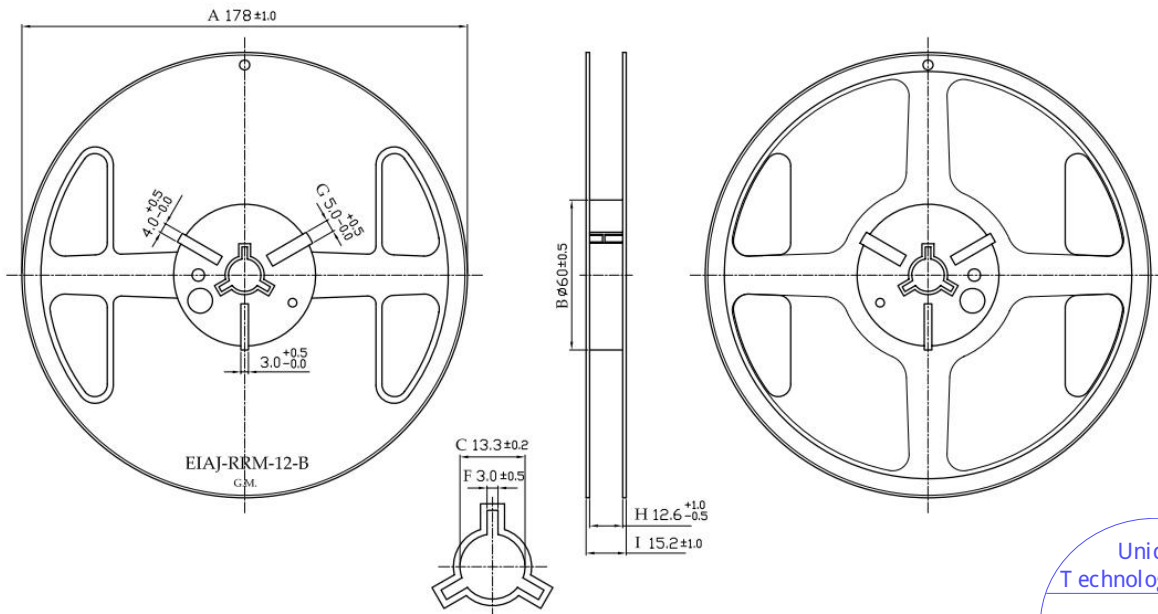

Unictron  
Technologies Corp.  
**2020-07-01**  
Document  
Control Center



**詠業科技股份有限公司**  
Unictron Technologies Corporation  
Website: www.unictron.com

THIS DRAWINGS AND SPECIFICATIONS ARE THE PROPERTY OF UNICTRON TECHNOLOGIES CORPORATION AND SHALL NOT BE REPRODUCED OR USED AS THE BASIS FOR THE MANUFACTURE OR SALE OF APPARATUS OR DEVICES WITHOUT PERMISSION

Prepared by : **Jane**      Designed by : **Peter**      Checked by : **Mike**      Approved by : **Herbert**

<b>TITLE : 3.2 x 1.6 x 0.5 (mm) WiFi Dual Band Chip Antenna (AA077) Engineering Specification</b>	<b>DOCUMENT NO. H2U84W1H1S0300</b>	REV.
		<b>L</b>

d. Drawing of small size carton in developed view

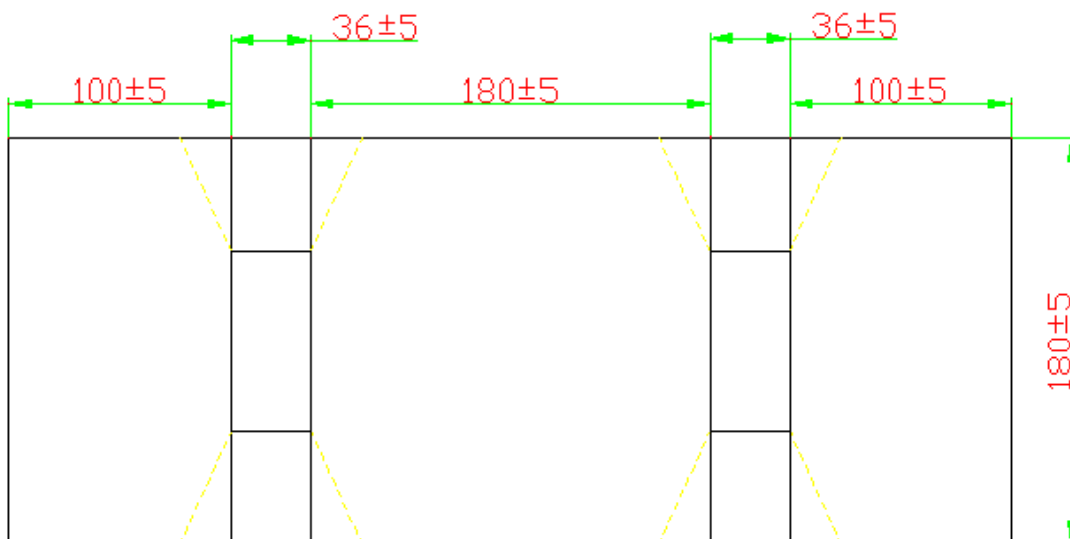

e. Drawing of middle size carton in developed view

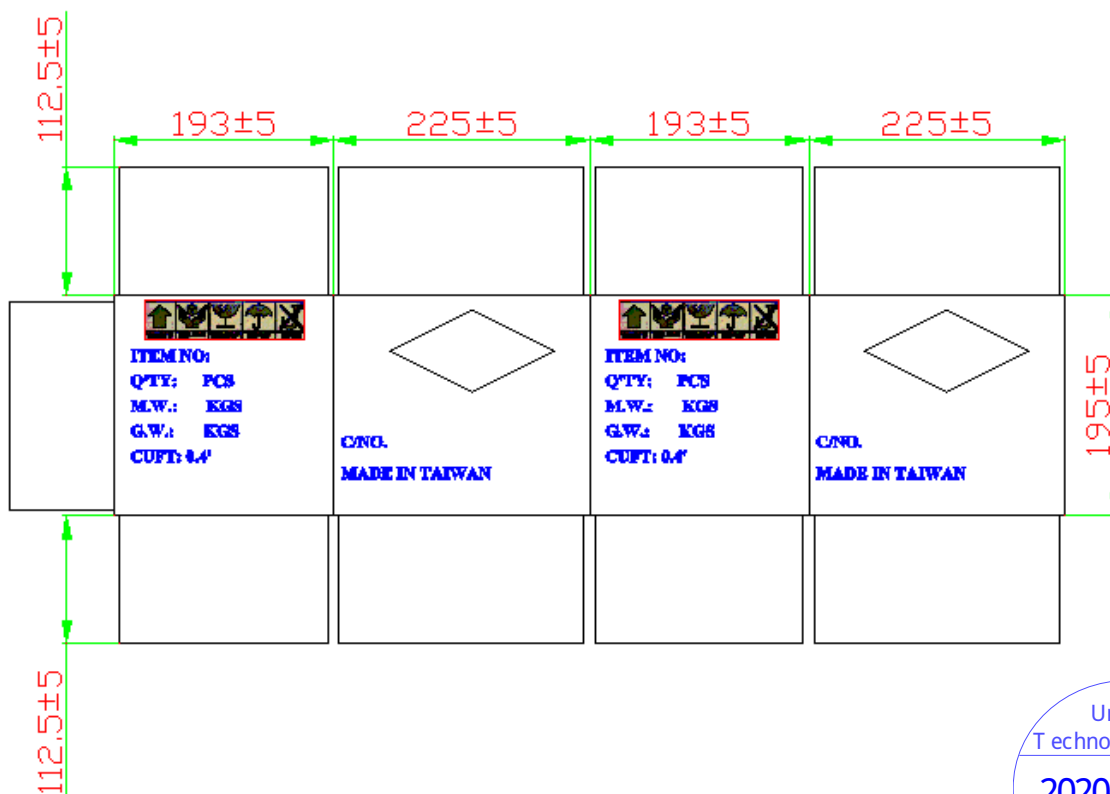

詠業科技股份有限公司  
Unictron Technologies Corporation  
Website: www.unictron.com

THIS DRAWINGS AND SPECIFICATIONS ARE THE PROPERTY OF UNICTRON TECHNOLOGIES CORPORATION AND SHALL NOT BE REPRODUCED OR USED AS THE BASIS FOR THE MANUFACTURE OR SALE OF APPARATUS OR DEVICES WITHOUT PERMISSION

Prepared by : Jane

Designed by : Peter

Checked by : Mike

Approved by : Herbert

TITLE : 3.2 x 1.6 x 0.5 (mm) WiFi Dual Band Chip Antenna (AA077) Engineering Specification

DOCUMENT NO.

H2U84W1H1S0300

REV. L

f. Drawing of large size carton in developed view

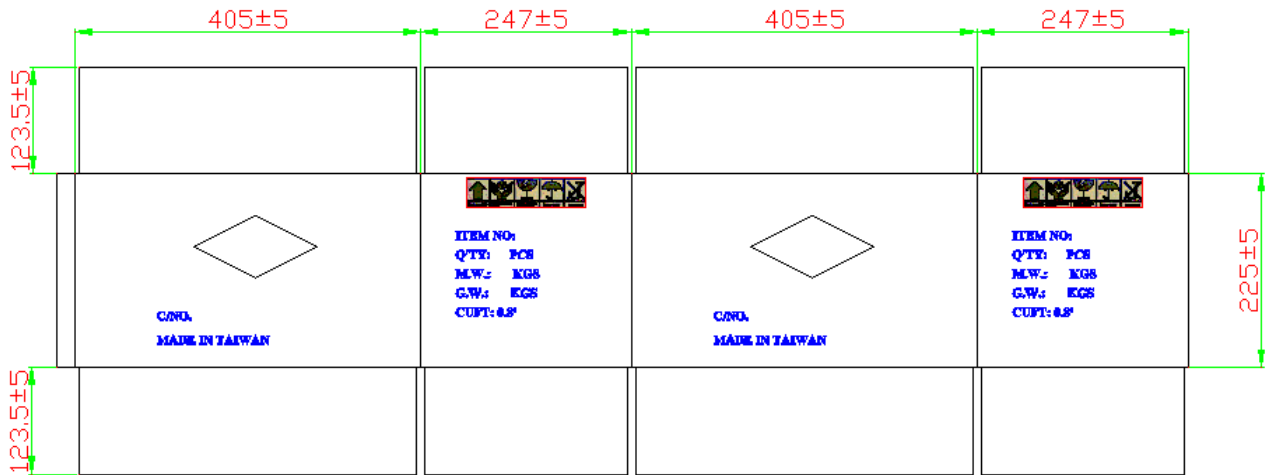

g. Picture of label

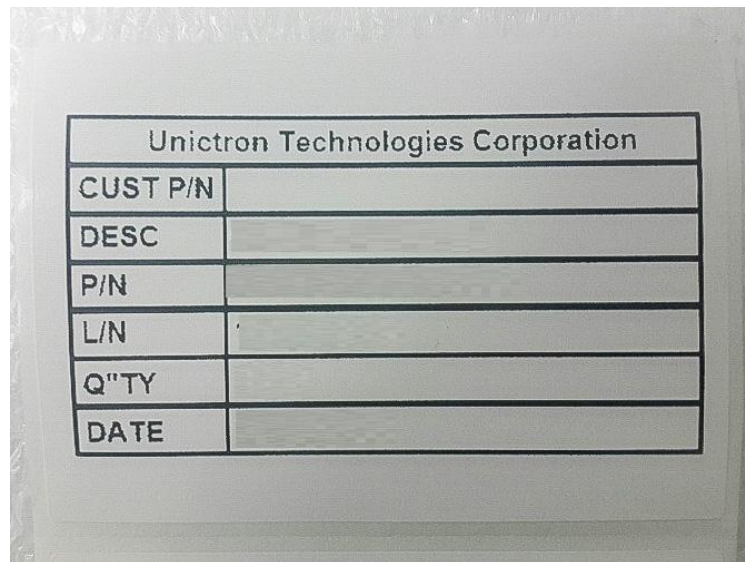

詠業科技股份有限公司  
Unictron Technologies Corporation  
Website: www.unictron.com

THIS DRAWINGS AND SPECIFICATIONS ARE THE PROPERTY OF UNICTRON TECHNOLOGIES CORPORATION AND SHALL NOT BE REPRODUCED OR USED AS THE BASIS FOR THE MANUFACTURE OR SALE OF APPARATUS OR DEVICES WITHOUT PERMISSION

Prepared by : Jane

Designed by : Peter

Checked by : Mike

Approved by : Herbert

TITLE : 3.2 x 1.6 x 0.5 (mm) WiFi Dual Band Chip Antenna (AA077) Engineering Specification

DOCUMENT NO.

H2U84W1H1S0300

REV.

L



h. Reel with label



i. Small size carton with label

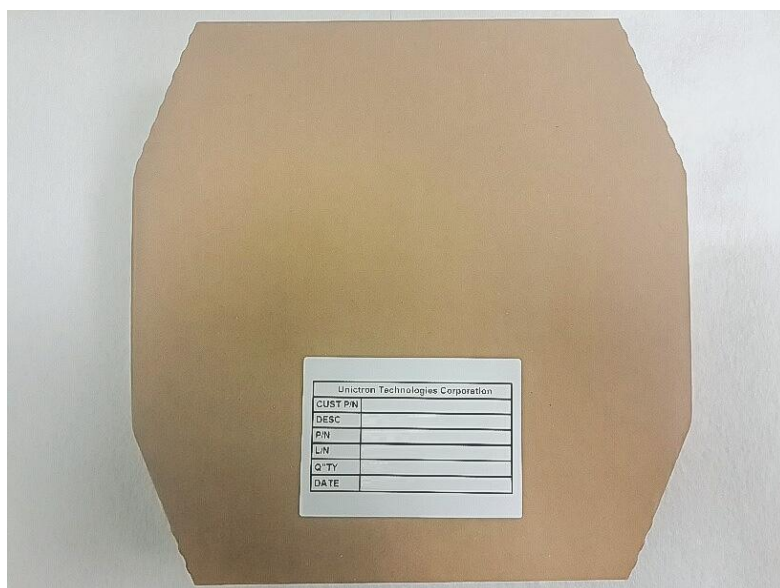

詠業科技股份有限公司  
 Unictron Technologies Corporation  
 Website:www.unictron.com

THIS DRAWINGS AND SPECIFICATIONS ARE THE PROPERTY OF UNICTRON TECHNOLOGIES CORPORATION AND SHALL NOT BE REPRODUCED OR USED AS THE BASIS FOR THE MANUFACTURE OR SALE OF APPARATUS OR DEVICES WITHOUT PERMISSION

Prepared by : Jane      Designed by :Peter      Checked by : Mike      Approved by : Herbert

TITLE : 3.2 x 1.6 x 0.5 (mm) WiFi Dual Band Chip Antenna (AA077) Engineering Specification	DOCUMENT NO.	H2U84W1H1S0300	REV.
			L

j. Middle size carton with label



11-2. Process of packing

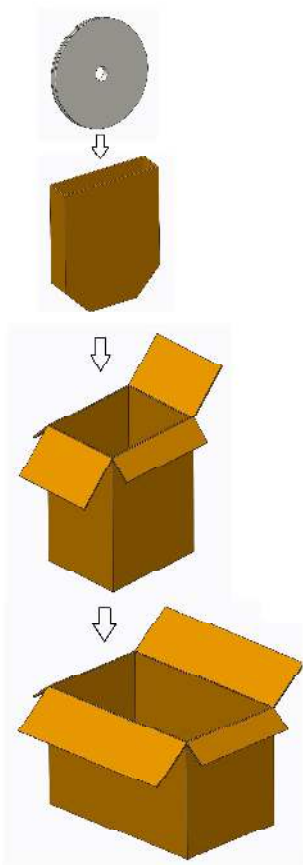

1 reel includes 5,000pcs(max.) chip antennas

1 small size carton includes 2pcs(max.) reels

1 middle size carton includes 5pcs(max.) small cartons

1 large size carton includes 2pcs(max.) middle cartons



詠業科技股份有限公司  
Unictron Technologies Corporation  
Website:www.unictron.com

THIS DRAWINGS AND SPECIFICATIONS ARE THE PROPERTY OF UNICTRON TECHNOLOGIES CORPORATION AND SHALL NOT BE REPRODUCED OR USED AS THE BASIS FOR THE MANUFACTURE OR SALE OF APPARATUS OR DEVICES WITHOUT PERMISSION

Prepared by : Jane

Designed by :Peter

Checked by : Mike

Approved by : Herbert

TITLE : 3.2 x 1.6 x 0.5 (mm) WiFi Dual Band Chip Antenna (AA077) Engineering Specification

DOCUMENT NO.

H2U84W1H1S0300

REV.  
L

## 12. Operating & Storage Conditions

### 12-1. Operating

- (1) Maximum Input Power: 2 W
- (2) Operating Temperature: -40°C to 85°C
- (3) Relative Humidity: 10% to 70%

### 12-2. Storage (sealed)

- (1) Storage Temperature: -5°C to 40°C
- (2) Relative Humidity: 20% to 70%
- (3) Shelf Life: 1 year

### 12-3. Storage (unsealed)

Meet the criteria of J-STD-033 MSL2a

### 12-4. Storage (After mounted on customer's PCB with SMT process)

- (1) Storage Temperature: -40°C to 85°C
- (2) Relative Humidity: 10% to 70%

## 13. Notice

### (1) Installation Guide:

Please refer to Unictron's application note "General guidelines for the installation of Unictron's chip antennas" for further information.

### (2) All specifications are subject to change without notice.



詠業科技股份有限公司  
Unictron Technologies Corporation  
Website: www.unictron.com

THIS DRAWINGS AND SPECIFICATIONS ARE THE PROPERTY OF UNICTRON TECHNOLOGIES CORPORATION AND SHALL NOT BE REPRODUCED OR USED AS THE BASIS FOR THE MANUFACTURE OR SALE OF APPARATUS OR DEVICES WITHOUT PERMISSION

Prepared by : **Jane**

Designed by : **Peter**

Checked by : **Mike**

Approved by : **Herbert**

**TITLE : 3.2 x 1.6 x 0.5 (mm) WiFi Dual Band Chip Antenna (AA077) Engineering Specification**

**DOCUMENT NO.**

**H2U84W1H1S0300**

**REV. L**