

THIS DRAWING IS UNPUBLISHED. RELEASED FOR PUBLICATION  
 © COPYRIGHT - By - ALL RIGHTS RESERVED.

LOC		DIST		REVISIONS			
P	LTR	DESCRIPTION		DATE	DWN	APVD	
AF	50	E		REVISED PER ECR-12-013518	26NOV2012	KH	PD

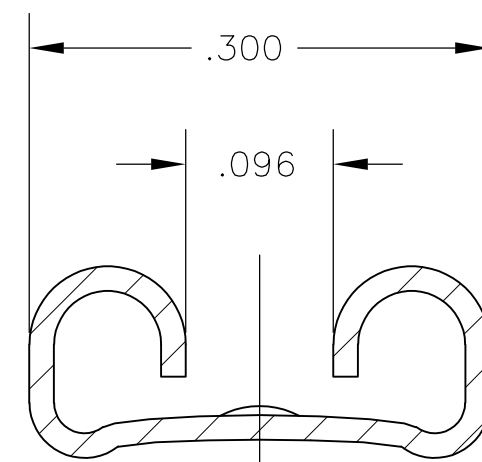

SECTION C-C

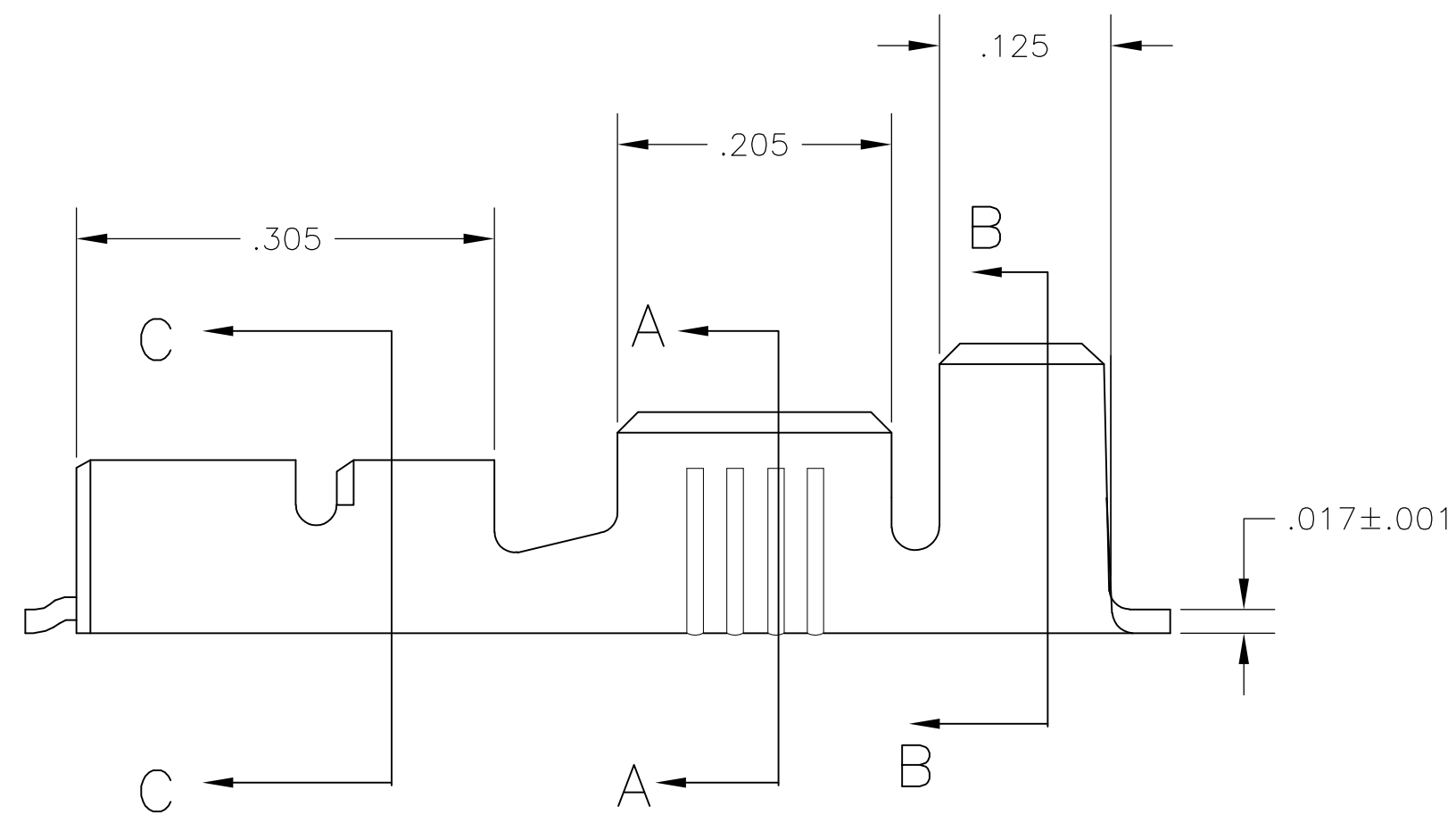
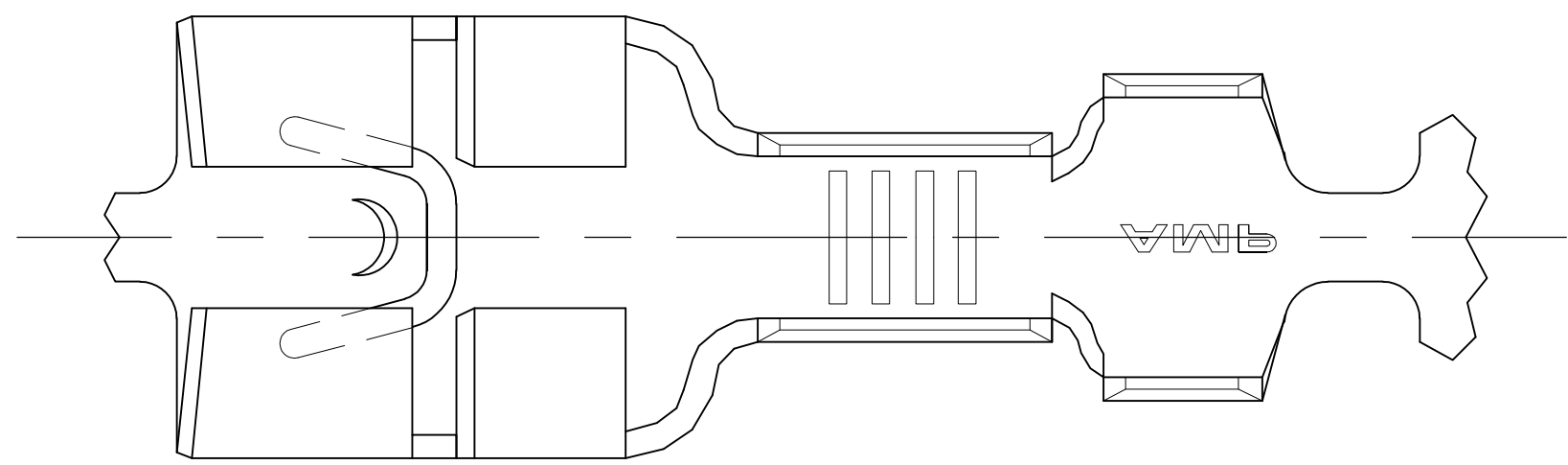
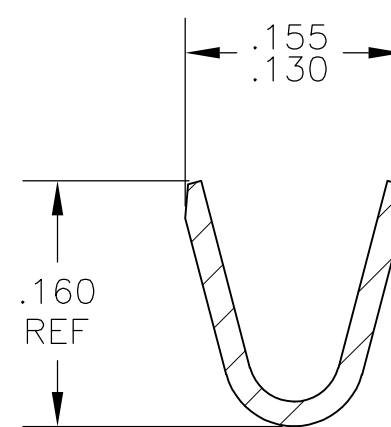

SECTION A-A

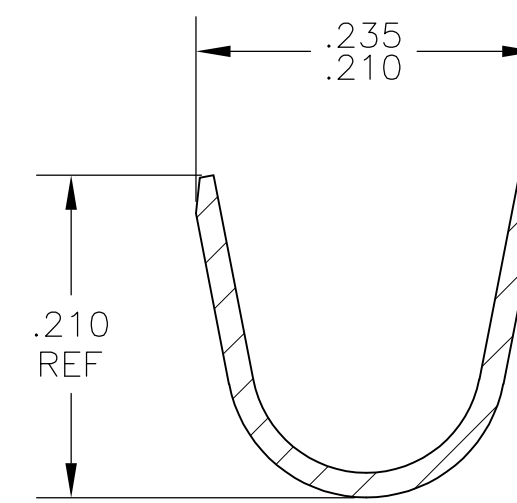

SECTION B-B

- 1 CONTINUOUS STRIP ON REELS
- 2 ACCEPTS #18-#14 AWG WIRE SIZE  
CRIMP WIDTH, .120, F TYPE
- 3 INSULATION RANGE IS .120-.170 DIA  
CRIMP WIDTH, .180, F OR O TYPE
- 4 MATING TAB THK IS .032±.001.
- 5 OBSOLETE PARTS: OBSOLETE CIS STREAMLINING  
PER D.RENAUD/D.SINISI

5	OBSOLETE	-	1217917-2
		.000080 MIN TIN	<del>1217917-1</del>
		FINISH	PART NO

THIS DRAWING IS A CONTROLLED DOCUMENT.		DWN	JR RUTH	22JAN03		TE Connectivity		
DIMENSIONS: INCHES		CHK	P DESANTIS	11NOV03		RECEPTACLE, FASTON, .250 SERIES		
TOLERANCES UNLESS OTHERWISE SPECIFIED:		APVD	P DESANTIS	22JAN03		SIZE	CAGE CODE	DRAWING NO
0 PLC ± - 1 PLC ± - 2 PLC ± - 3 PLC ± .010 4 PLC ± - ANGLES ± - FINISH SEE TABLE		PRODUCT SPEC	-			A2	00779	C=1217917
MATERIAL	BRASS	APPLICATION SPEC	-		WEIGHT	-	RESTRICTED TO	
		WEIGHT	-		CUSTOMER DRAWING	SCALE	1:1	
		SCALE	1:1		SHEET	1 of 1		
		REV	E					