

CONNECTOR P/N	CONNECTOR TYPE	HOUSING COLOR	ØD (µm)	Ød (µm)
1063975320	Single Mode	Blue	125.5 +0.5/-0	0.5
1063975321			126.0 +1.0/-0	1.0
1063975520	Multimode	Gold	127.0 +3.0/-0	3.0

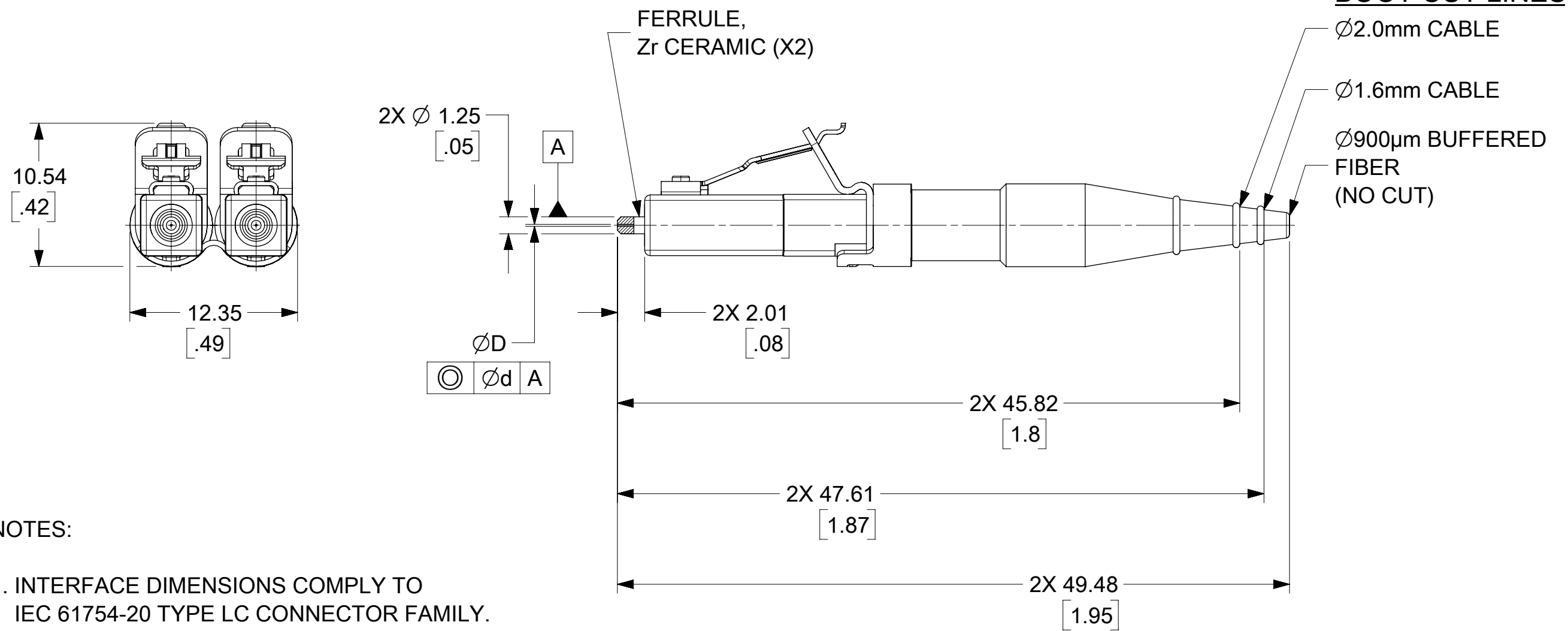
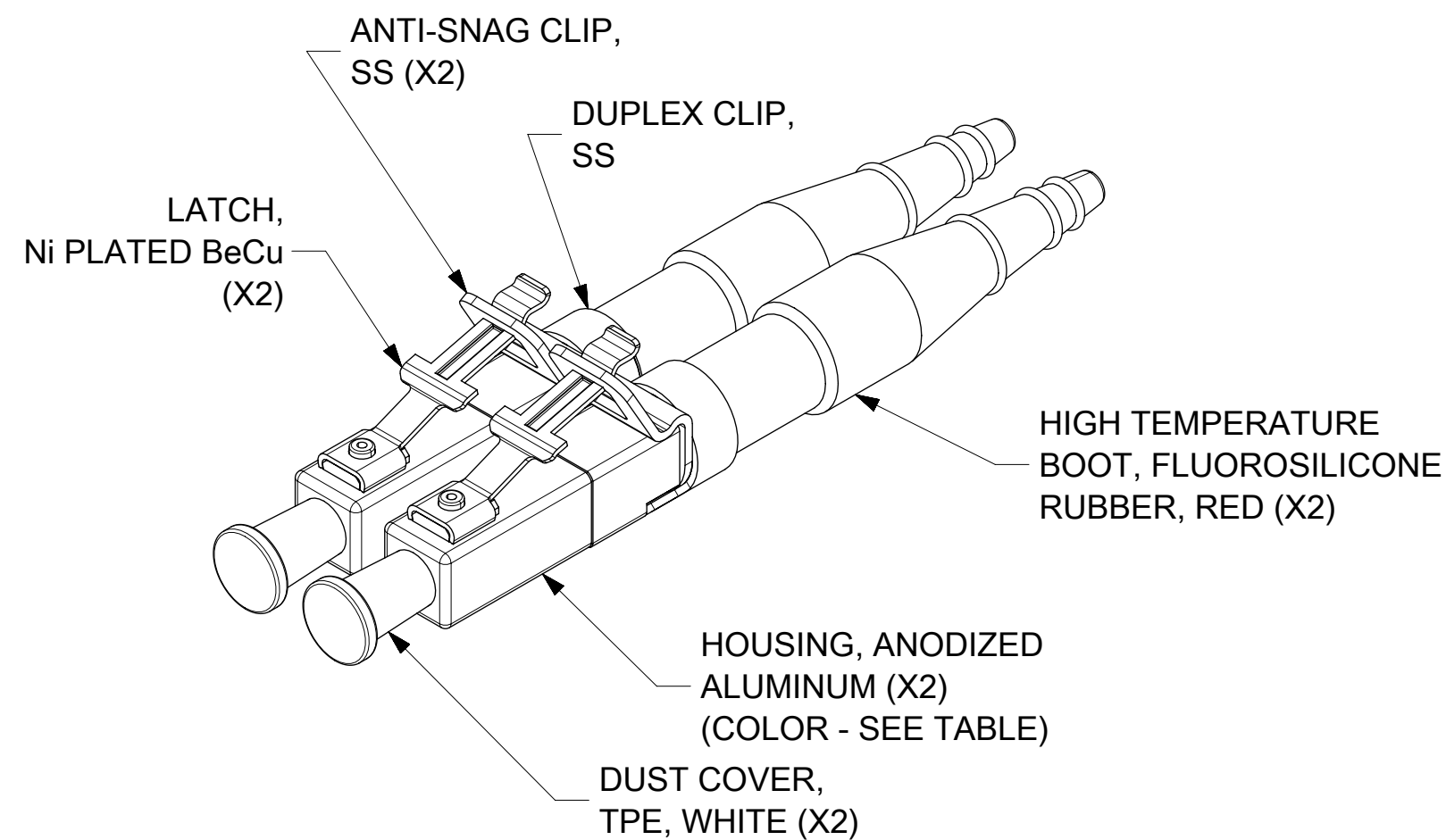
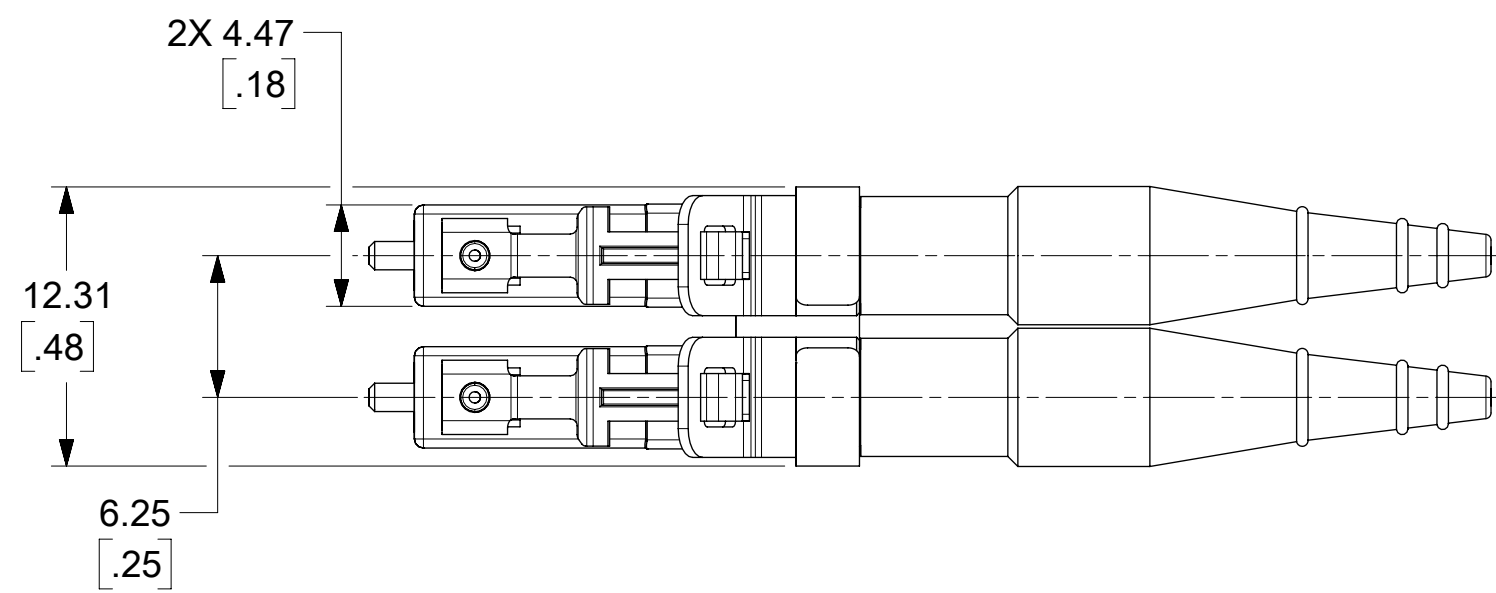

NOTES:

- INTERFACE DIMENSIONS COMPLY TO IEC 61754-20 TYPE LC CONNECTOR FAMILY.
- BOOT TO BE CUT AT LINES AS SHOWN DEPENDING ON THE CABLE SIZE.
- FOR TERMINATION PROCEDURE USE STANDARD LC TERMINATION PROCEDURE. (RECOMMENDED CRIMP TOOL P/N 867445000)
- CONNECTOR TESTED TO PASS FOLLOWING STANDARDS:
 - TELCORDIA GR-326-CORE. THERMAL CYCLE CONDITIONS MODIFIED TO BE -60°C TO +150°C (REFER TO TEST REPORT TR8797)
 - EIA-364 (REFER TO TEST REPORT TR8797)

CONNECTOR IS SOLD AS A KIT. CUSTOMER IS RESPONSIBLE TO PERFORM THEIR OWN TEST TO VERIFY THEIR TERMINATION PROCESS AS A FINISHED PRODUCT.

FUNCTIONAL SYMBOLS	THIS DRAWING CONTAINS INFORMATION THAT IS PROPRIETARY TO MOLEX ELECTRONIC TECHNOLOGIES, LLC AND SHOULD NOT BE USED WITHOUT WRITTEN PERMISSION		CURRENT REV DESC:		molex
	DIMENSION UNITS	SCALE			
▽A = 0	MM/INCH	3:1			LC2+ METAL HIGH TEMP CONNECTOR, DUPLEX
▽E = 0	GENERAL TOLERANCES (UNLESS SPECIFIED)				
▽P = 0	ANGULAR TOL ± 1.0°				PRODUCT CUSTOMER DRAWING
DIVISIONAL SYMBOLS	4 PLACES ±		EC NO: 655686		
	3 PLACES ±		DRWN: IGUMIN 2021/02/15		
	2 PLACES ±		CHK'D: GGENCHANOK 2021/02/18		
	1 PLACE ±		APPR: GGENCHANOK 2021/02/18		
	0 PLACES ±		INITIAL REVISION:		
	DRAFT WHERE APPLICABLE MUST REMAIN WITHIN DIMENSIONS		DRWN: EEFUNG 2010/06/03		DOCUMENT NUMBER
	THIRD ANGLE PROJECTION		APPR: WCHEN 2010/06/10		SD-106397-5320
	DRAWING		SERIES		DOC TYPE
	C-SIZE		106397		PSD
	MATERIAL NUMBER		CUSTOMER		DOC PART
	SEE TABLE				001
	SHEET NUMBER				REVISION
	1 OF 1				B1