

REV.	LOCAS.	DESCRIPTION	DATE	DRAWN
01	NEW	BATCH PRODUCTION INITIAL RELEASE.	2022.04.19	劉先平

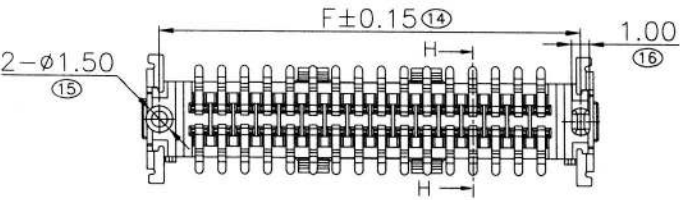
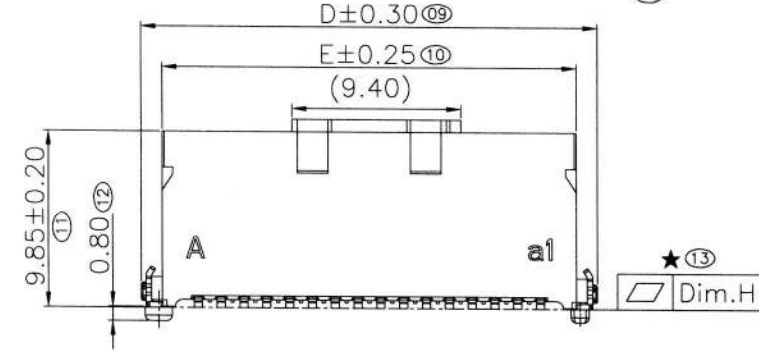
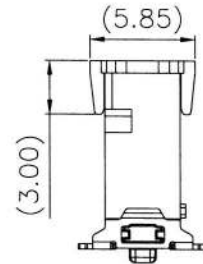
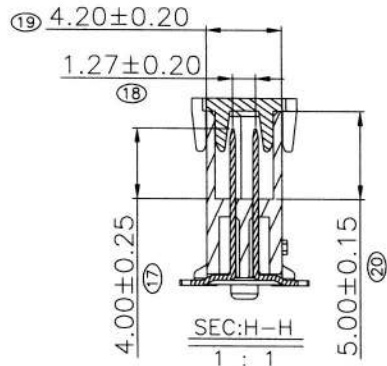
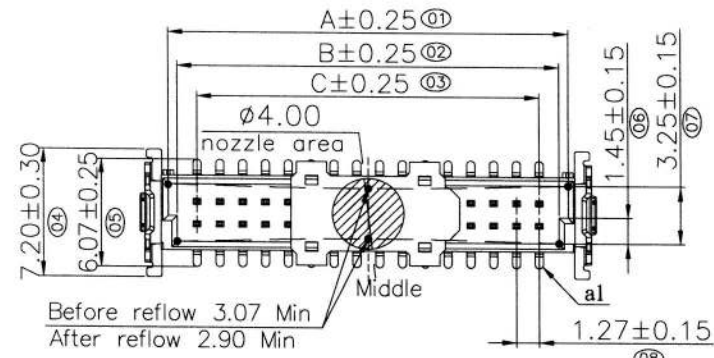

Specifications
 Current Rating:1.70Amp/pin
 Insulation Resistance:10000MΩMin.
 Dielectric Withstanding Voltage:500VAC
 Contact Resistance:25mΩMax.
 Operating Temperature:-55°C to +125°C
Materials
 Contact Material:Phosphor Bronze
 Insulator Material:High Temperature Thermoplastic, UL 94V-0 LCP or the equivalent material
 ☆ All materials must meet GREENCONN hazardous substances control standards.
 "★": Critical Characteristics, indicates product characteristics, functionalities, and manufacturing processes regarding to customer's specifications
 "☆": Safety Features indicates product characteristics, functionalities, and manufacturing processes complying to legal regulations stated by local government

No. of PIN/ROW	Dimension Information					
	A	B	C	D	E	F
2x5	8.30	7.30	5.08	11.43	9.08	9.50
2x6	9.57	8.57	6.35	12.70	10.35	10.77
2x8	12.11	11.11	8.89	15.24	12.89	13.31
2x10	14.65	13.65	11.43	17.78	15.43	15.85
2x13	18.46	17.46	15.24	21.59	19.24	19.66
2x16	22.27	21.27	19.05	25.40	23.05	23.47
2x20	27.35	26.35	24.13	30.48	28.13	28.55
2x25	33.70	32.70	30.48	36.83	34.48	34.90
2x34	45.13	44.13	41.91	48.26	45.91	46.33
2x40	52.75	51.75	49.53	55.88	53.53	53.95

Pin No.	Dim.H
≤ 25pin	0.12
> 25pin	0.15

Recommended P.C.Board Layout
(Tolerance:±0.05)

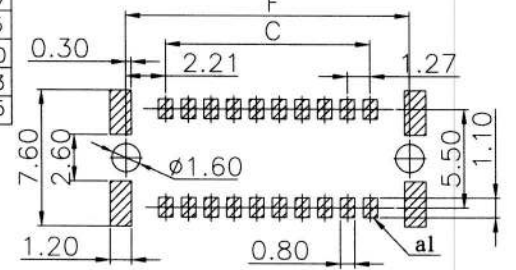

Ordering Information

G BEC208- XX XX B 001 C 1 A X

No. of Pins per Row: 05,06,08,10,13,16, 20,25,34,40
 Standard Plating: 79=5u"Au/80~160u"Matte Tin
 Selective Plating: 02=Gold Flash
 05=1u"Au/80~160u" Tin
 Color: 1=Black
 Standard Packing: F=cap+tape&reel
 Selective Packing: C=tube

 Website:www.greenconn.com E-mail:sales@greenconn.com	3RD.ANG PROJ.	GENERAL TOLERANCE	DESIGNED: 劉先平	DATE: 2022.04.19	DWG. NO. GBEC208-CB001	TITLE. Pitch 1.27 male Connector SMC Q TYPE SMT TYPE 180°
	 PAGE. 1/1	X.±5.0° X.±0.30	CHECKED: 木村	DATE: 2022.4.19		
	REV. 01	UNIT. mm	SCALE. 2:5	APPROVED: 刘先平	DATE: 2022.04.19	