

**PI3USB4000DQ**

**Ultra-High Voltage Protection USB2 1:2 Mux/DeMux**

**Features**

- Differential Bi-directional 2:1 Mux/DeMux
- Wide Input Voltage Range: 0 to 5.5V
- Wide bandwidth: 1GHz
- Ultra-low Con: 7pF
- Ultra-low Ron: 5Ω (typ)
- Low Propagation Delay, 0.25ns typ
- Low Off-Isolation, -30dB@240MHz
- Low Crosstalk: -35dB@240MHz,
- Low Power Consumption: 35μA typical
- Wide Supply Voltage 2.7 to 5.5V
- Support 1.8V Logic on Control Pins
- Protection Feature
  - ◆ Off-protection for current leakage in power-down mode
  - ◆ All I/O pins are high voltage tolerance
    - C0+/C0- tolerance to 24V
    - Lx+/- tolerance to 6V
    - V<sub>DD</sub> tolerance to 6V
  - ◆ Over-voltage protection when Vbus short to C0-/C0+ when device is power-on and enabled
- ESD Protection on (C0+/-)
  - ◆ IEC61000-4-2, 10kV
- Wide Temperature Range: -40°C to 125°C
- Automotive Grade 1 temperature range (-40 to 125°C)
- Totally Lead-Free & Fully RoHS Compliant (Notes 1 & 2)
- Halogen and Antimony Free. "Green" Device (Note 3)
- For automotive applications requiring specific change control (i.e. parts qualified to AEC-Q100/101/200, PPAP capable, and manufactured in IATF 16949 certified facilities), please [contact us](https://www.diodes.com/quality/product-definitions/) or your local Diodes representative.
- Packaging (Pb-free & Green):
  - ◆ 10-contact, UQFN (ZUA), 1.5x2mm, 0.5mm(H), 0.6mm pitch

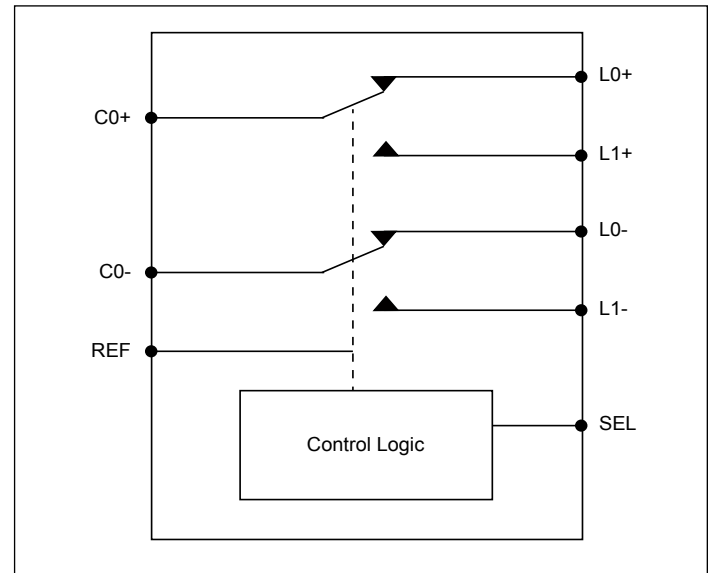
**Description**

The PI3USB4000DQ is a 2-to-1 differential channel multiplexer/demultiplexer switch. C0+/C0- pins can tolerate voltages up to 24V. Over-voltage protection (OVP) is implemented at 4.75V to immediately switch off the channels when over-voltage condition is detected. PI3USB4000DQ can pass USB2.0 signal with bandwidth 1GHz to maintain signal integrity and eye diagram open.

**Applications**

- Smart Phone, USB-C application, Tablets, NB, PC

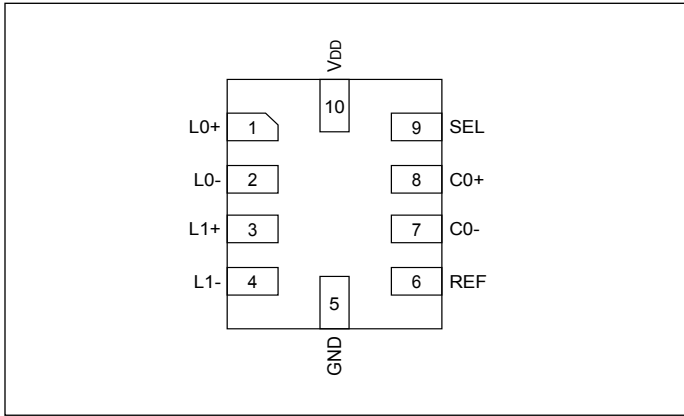
**Block Diagram**



**Notes:**

1. No purposely added lead. Fully EU Directive 2002/95/EC (RoHS), 2011/65/EU (RoHS 2) & 2015/863/EU (RoHS 3) compliant.
2. See <https://www.diodes.com/quality/lead-free/> for more information about Diodes Incorporated's definitions of Halogen- and Antimony-free, "Green" and Lead-free.
3. Halogen- and Antimony-free "Green" products are defined as those which contain <900ppm bromine, <900ppm chlorine (<1500ppm total Br + Cl) and <1000ppm antimony compounds.

## Pin Configuration



## Pin Description

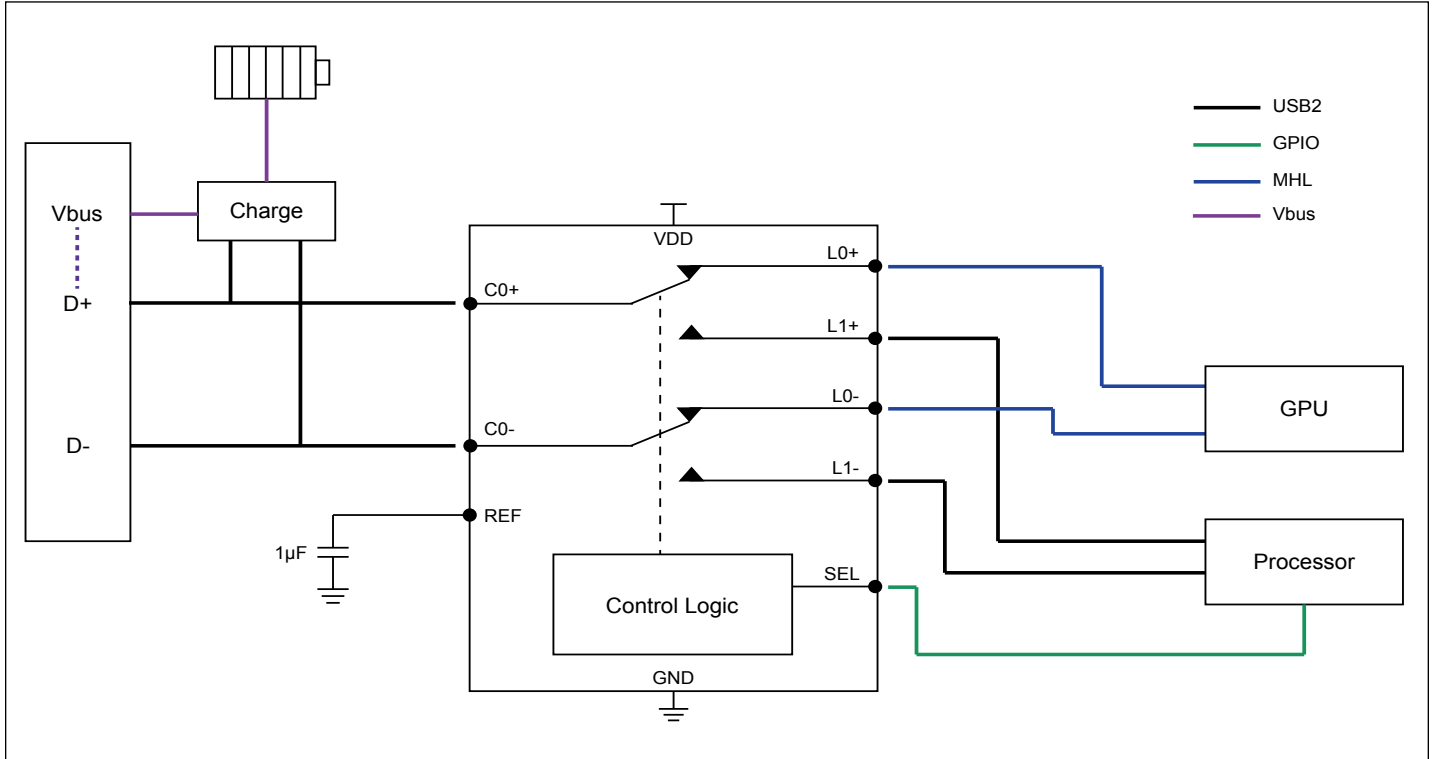
Pin#	Pin Name	Signal Type	Description
8, 7	C0+, C0-	I/O	Signal I/O, Common Port
3, 4	L1+, L1-	I/O	Signal I/O, Channel 1
1, 2	L0+, L0-	I/O	Signal I/O, Channel 0
9	SEL	I	Operation mode Select (when SEL=0: C0→L0, when SEL=1: C0→L1)
6	REF	PWR	Reference pin, tie to GND through cap*
10	V <sub>DD</sub>	PWR	Positive Supply Voltage
5	GND	PWR	Power ground

\* The Cap on the REF pin required 1uF and 25V tolerance

## Truth Table

Function	SEL
C0+/- to L0+/-	L
C0+/- to L1+/-	H

**PI3USB4000DQ application in MHL Switching and provide overvoltage protection for D+/- when high voltage charging**



**Note:**

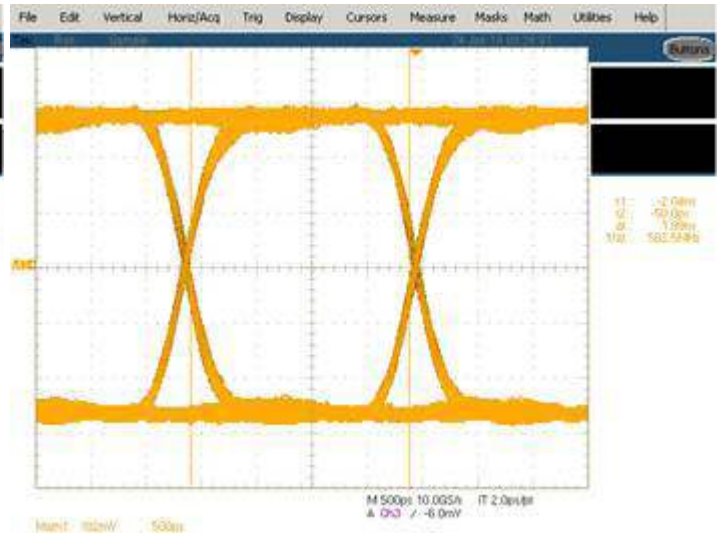
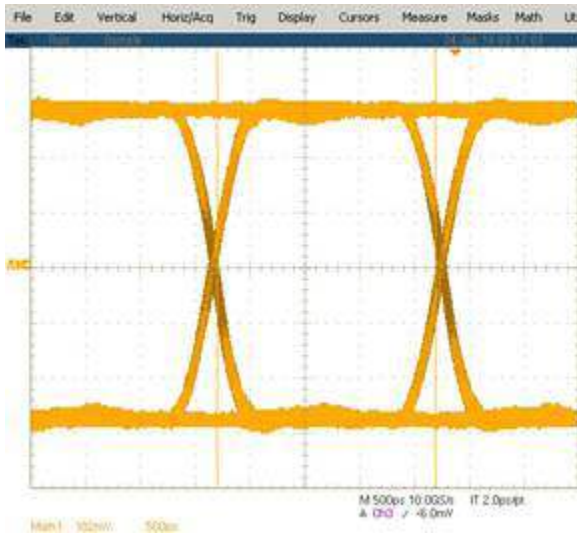
The capacitor connected to REF pin should have rated voltage higher than maximum voltage applied to C0+/- pins; the max rating of device on C0+/- is 24V, customer can select lower voltage capacitor if system required lower voltage tolerance on C0+/-; capacitance of 1uF.

1. The 1uF capacitor recommend to be placed to the REF and GND pin of the device as close as possible
2. The decoupling capacitor at the VDD recommend to be placed to the device as close as possible.
3. Keep the trace between connector and device as long as possible; if needs inductor between device and connector, it recommend to be placed to the USB connector as close as possible and leaving some trace line between the device and the inductor would help some for the ESD performance.

**USB2.0 High Speed (480Mbps) Eye Diagram**

No Device (Trace Only)

With USB4000DQ



## Maximum Ratings

(Above which useful life may be impaired. For user guidelines, not tested.)

Storage Temperature .....	-65°C to +150°C
Supply Voltage (VDD) to Ground Potential .....	-0.3V to +6V
Channel Input/Output Voltage (Lx+/-) .....	-0.3V to +6V
Channel Input/Output Voltage (C0+/-) .....	-0.3V to +24V
Reference Pin Voltage (REF) to Ground Potential.....	-0.3V to +24V
Control Pins Input Voltage (SEL).....	-0.3V to +6V
ESD (All Pins).....	2KV (HBM) and 1KV (CDM)
Channel Input/Output Current (Lx/C0).....	±25mA

**Note:**

Stresses greater than those listed under MAXIMUM RATINGS may cause permanent damage to the device. This is a stress rating only and functional operation of the device at these or any other conditions above those indicated in the operational sections of this specification is not implied. Exposure to absolute maximum rating conditions for extended periods may affect reliability.

## Recommended Operating Conditions

Symbol	Description	Test Conditions	Min.	Typ.	Max.	Units
$V_{DD}$	Power Supply		2.7	3.3	5.5	V
$V_{I/O}$	Analog Voltage Range		0		5.5	V
$V_I$	Voltage Range for Control Pins		0		5.5	V
$I_{DD}$	Current Consumption in Normal Operation	$V_{DD} = 3.3V, V_{I/O} = 0V, SEL = GND$ or $V_{DD}$ , chip enabled		35	45	$\mu A$
$I_{DD\_OVP}$	Current Consumption in OVP	$V_{DD} = 3.3V, V_{C0+}/V_{C0-} = 5.5V,$ $SEL = GND$ or $V_{DD}$ , chip enabled		35		$\mu A$
$T_A$	Operating Temperature Range		-40		125	$^{\circ}C$

## DC Electrical Characteristics for Switching over Operating Range

( $T_A = -40^{\circ}C$  to  $125^{\circ}C$ , Typical values are at  $V_{DD} = 3.3V$ ,  $T_A = 25^{\circ}C$ ,  $REF = NC$  (unless otherwise noted))

Parameter	Description	Test Conditions	Min.	Typ.	Max.	Units
<b>Control Pins – SEL</b>						
$V_{IH}$ - cntrl signals	Input HIGH Voltage for SEL	$V_{DD} = 2.7-5.5V$	1.2			V
$V_{IL}$ - cntrl signals	Input LOW Voltage for SEL	$V_{DD} = 2.7-5.5V$			0.6	V
$I_{IH}$	Input HIGH Current for SEL	$V_I = 5.5V$	-1		1	$\mu A$
$I_{IL}$	Input LOW Current for SEL	$V_I = 0V$	-1		1	$\mu A$
<b>High Speed IO – L0/L1/C0</b>						
$V_{OVP}$	$CO_{\pm}$ OVP trigger voltage		4.6	4.75	5.0	V
$R_{on}$	ON resistance	$V_{I/O} = 0V, 0.4V, I_{on} = -8 mA$		5	10	$\Omega$
$\Delta R_{on}$	On resistance between + and – channel	$V_{I/O} = 0V, 0.4V, I_{on} = -8 mA$		0.5	1	$\Omega$
$R_{on\_Flat}$	ON resistance flatness	$V_{I/O} = 0V, 0.4V, I_{on} = -8 mA$		0.2	0.5	$\Omega$
$I_{off}$	$CO_{\pm}$ Power-off leakage	$V_{DD} = 0V, V_{CO_{\pm}} = 0-3.6V$	-1		1	$\mu A$
$I_{OC}$	Channel off leakage current	$V_{DD} = 3.3V, V_{Lx_{\pm}} = 0-3.6V,$ channel is off	-1		1	$\mu A$
$I_{ON}$	Channel on leakage current	$V_{DD} = 3.3V, V_{Lx_{\pm}} = 0-3.6V,$ channel is on	-1		1	$\mu A$

### DC Electrical Characteristics for Switching over Operating Range Cont.

Parameter	Description	Test Conditions	Min.	Typ.	Max.	Units
I <sub>OVP</sub>	Leakage current on C0+/C0- in OVP mode	V <sub>DD</sub> = 3.3V, V <sub>C0+</sub> or V <sub>C0-</sub> = 20V			1	mA
Z <sub>ON_GND</sub>	On-State impedance to GND	SEL = H or L V <sub>I/O</sub> = 0-3.6V	3.5	7		MΩ

### Dynamic Electrical Characteristics

(T<sub>A</sub> = -40°C to 125°C, Typical values are at V<sub>DD</sub> = 3.3V, T<sub>A</sub> = 25°C, (unless otherwise noted))

Parameter	Description	Test Conditions	Min.	Typ.	Max.	Units
<b>Control Pins – SEL</b>						
C <sub>I</sub>	Input Capacitance	f=1MHz		5		pF
<b>High Speed IO – L0/L1/C0</b>						
C <sub>on</sub>	ON Capacitance	f=1MHz		7		pF
C <sub>off</sub>	OFF Capacitance	f=1MHz		9		pF
DDIL	Insertion Loss	f=240MHz		-0.5		dB
DDRL	Differential Return Loss	f=240MHz		-15		dB
DDOI	Differential OFF Isolation	f=240MHz		-30		dB
		f=100kHz		-80		dB
DDXT	Differential Crosstalk	f=240MHz		-35		dB
BW	-3dB Bandwidth			1		GHz

### Switching Characteristics<sup>(1)</sup>

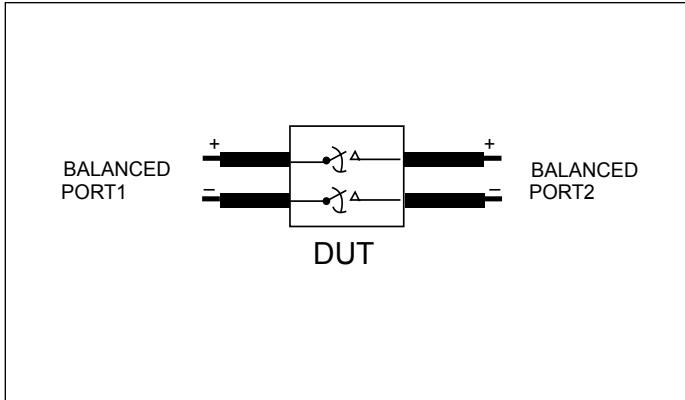
(T<sub>A</sub> = -40°C to 125°C, Typical values are at V<sub>DD</sub> = 3.3V, T<sub>A</sub> = 25°C, (unless otherwise noted))

Parameter	Description	Test Conditions	Min.	Typ.	Max.	Units
t <sub>OVP</sub>	OVP Response Time <sup>(1)</sup>	R <sub>LX</sub> = 600Ω, time from the voltage on C0± = 4~6V to the voltage on L <sub>X</sub> ± = 4.75V		0.5	1	μs
t <sub>PZH</sub> , t <sub>PZL</sub>	Line Enable Time	See Test Circuit for Electrical Characteristics		20		μs
t <sub>PHZ</sub> , t <sub>PLZ</sub>	Line Disable Time			50		ns
t <sub>p</sub> d	Propagation Delay			250		ps
t <sub>b-b</sub>	Bit-to-bit Skew Within the Same Differential Pair <sup>(1)</sup>			8	20	ps
T <sub>on</sub>	Device Enable Time			100		μs
T <sub>off</sub>	Device Disable Time			50		ns

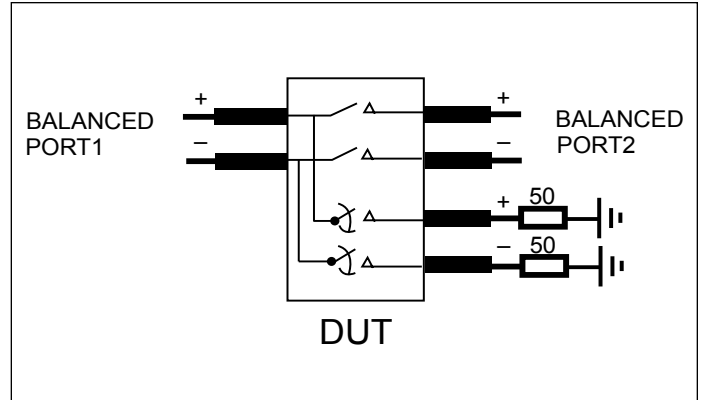
**Note:**

- 1. Guaranteed by design.

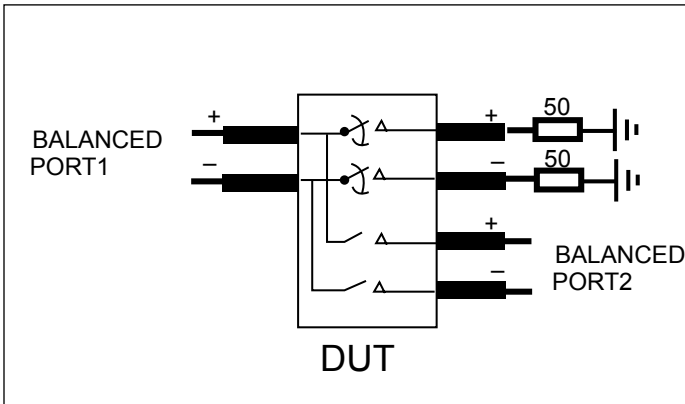
**PI3USB4000DQ**



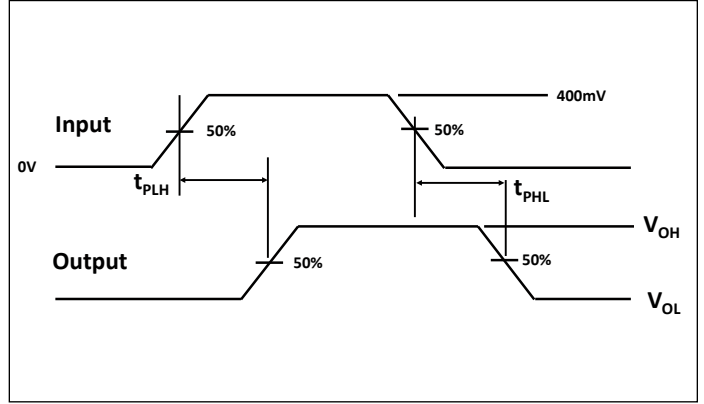
**Fig 1. Differential Insertion Loss Setup**



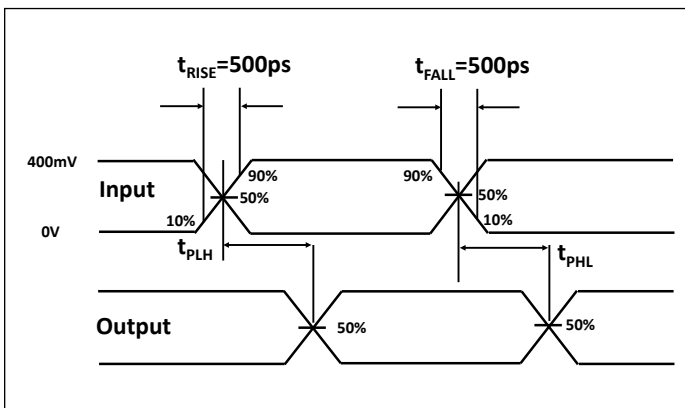
**Fig 2. Off-isolation Setup**



**Fig 3. Crosstalk Setup**

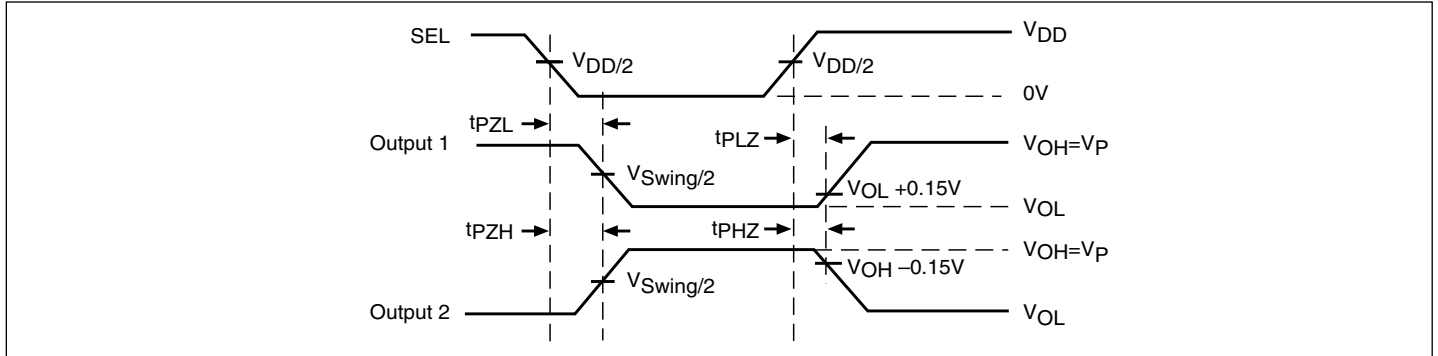


**Fig 4. Propagation Delay**



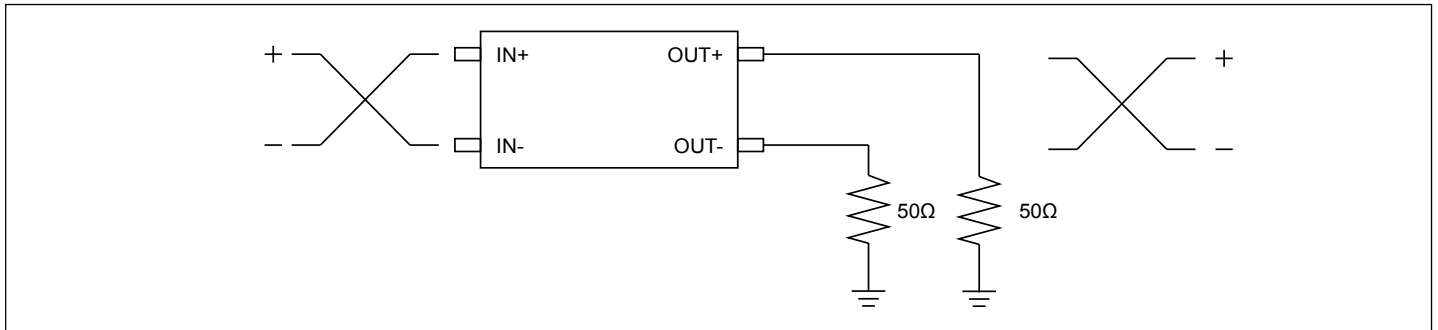
**Fig 5. Skew Test**

**Switching Waveforms**

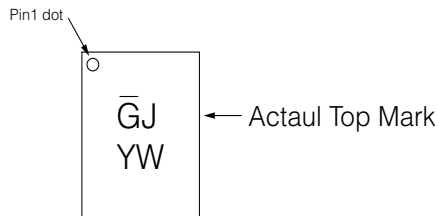


**Voltage Waveforms Enable and Disable Times**

**Test Circuit for Propagation Delay**

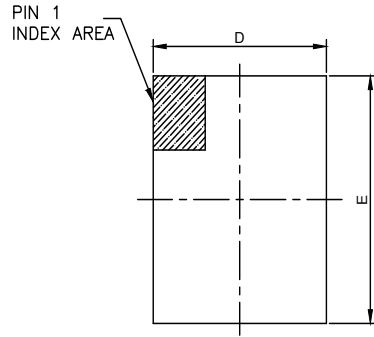


**Part Marking**

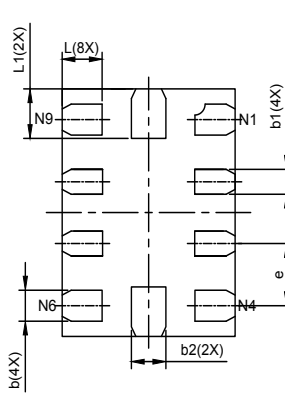


Y: Year  
W: Workweek  
Note: Date Code per MA-1251

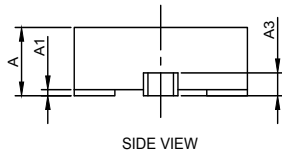
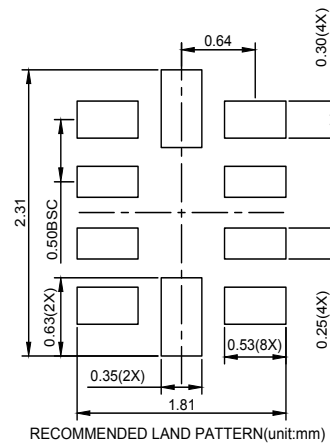
**Packaging Mechanical: 10-UQFN (ZUA)**



TOP VIEW



BOTTOM VIEW



SIDE VIEW

PKG. DIMENSIONS(MM)			
SYMBOL	Min	NOM	Max
A	0.50	0.60	0.65
A1	0.00	0.02	0.05
A3	0.15 REF		
D	1.45	1.50	1.55
E	1.95	2.00	2.05
b	0.20	0.25	0.30
b1	0.15	0.20	0.25
b2	0.25	0.30	0.35
e	0.50 BSC		
L	0.25	0.35	0.45
L1	0.30	0.40	0.50

**Notes:**

1. Ref: JEDEC MO-288B.

**DESCRIPTION: 10-Pin, UQFN, 1.5X2.0**

**PACKAGE CODE: ZUA(ZUA10)**

**DOCUMENT CONTROL#: PD-2220**

**REVISION: --**

17-0002

**For latest package info.**

please check: <http://www.diodes.com/design/support/packaging/pericom-packaging/packaging-mechanicals-and-thermal-characteristics/>

**Ordering Information**

Ordering Code	Package Code	Package Description
PI3USB4000DQ1ZUAEX	ZUA	10-Pin, 1.5x2.0 (UQFN)

**Notes:**

1. No purposely added lead. Fully EU Directive 2002/95/EC (RoHS), 2011/65/EU (RoHS 2) & 2015/863/EU (RoHS 3) compliant.
2. See <https://www.diodes.com/quality/lead-free/> for more information about Diodes Incorporated's definitions of Halogen- and Antimony-free, "Green" and Lead-free.
3. Halogen- and Antimony-free "Green" products are defined as those which contain <900ppm bromine, <900ppm chlorine (<1500ppm total Br + Cl) and <1000ppm antimony compounds.
4. Q = Automotive Compliant
5. 1 = AEC-Q100 Grade Level
6. E = Pb-free and Green
7. X suffix = Tape/Reel



**IMPORTANT NOTICE**

1. DIODES INCORPORATED AND ITS SUBSIDIARIES ("DIODES") MAKE NO WARRANTY OF ANY KIND, EXPRESS OR IMPLIED, WITH REGARDS TO ANY INFORMATION CONTAINED IN THIS DOCUMENT, INCLUDING, BUT NOT LIMITED TO, THE IMPLIED WARRANTIES OF MERCHANTABILITY, FITNESS FOR A PARTICULAR PURPOSE OR NON-INFRINGEMENT OF THIRD PARTY INTELLECTUAL PROPERTY RIGHTS (AND THEIR EQUIVALENTS UNDER THE LAWS OF ANY JURISDICTION).
2. The Information contained herein is for informational purpose only and is provided only to illustrate the operation of Diodes products described herein and application examples. Diodes does not assume any liability arising out of the application or use of this document or any product described herein. This document is intended for skilled and technically trained engineering customers and users who design with Diodes products. Diodes products may be used to facilitate safety-related applications; however, in all instances customers and users are responsible for (a) selecting the appropriate Diodes products for their applications, (b) evaluating the suitability of the Diodes products for their intended applications, (c) ensuring their applications, which incorporate Diodes products, comply the applicable legal and regulatory requirements as well as safety and functional-safety related standards, and (d) ensuring they design with appropriate safeguards (including testing, validation, quality control techniques, redundancy, malfunction prevention, and appropriate treatment for aging degradation) to minimize the risks associated with their applications.
3. Diodes assumes no liability for any application-related information, support, assistance or feedback that may be provided by Diodes from time to time. Any customer or user of this document or products described herein will assume all risks and liabilities associated with such use, and will hold Diodes and all companies whose products are represented herein or on Diodes' websites, harmless against all damages and liabilities.
4. Products described herein may be covered by one or more United States, international or foreign patents and pending patent applications. Product names and markings noted herein may also be covered by one or more United States, international or foreign trademarks and trademark applications. Diodes does not convey any license under any of its intellectual property rights or the rights of any third parties (including third parties whose products and services may be described in this document or on Diodes' website) under this document.
5. Diodes products are provided subject to Diodes' Standard Terms and Conditions of Sale (<https://www.diodes.com/about/company/terms-and-conditions/terms-and-conditions-of-sales/>) or other applicable terms. This document does not alter or expand the applicable warranties provided by Diodes. Diodes does not warrant or accept any liability whatsoever in respect of any products purchased through unauthorized sales channel.
6. Diodes products and technology may not be used for or incorporated into any products or systems whose manufacture, use or sale is prohibited under any applicable laws and regulations. Should customers or users use Diodes products in contravention of any applicable laws or regulations, or for any unintended or unauthorized application, customers and users will (a) be solely responsible for any damages, losses or penalties arising in connection therewith or as a result thereof, and (b) indemnify and hold Diodes and its representatives and agents harmless against any and all claims, damages, expenses, and attorney fees arising out of, directly or indirectly, any claim relating to any noncompliance with the applicable laws and regulations, as well as any unintended or unauthorized application.
7. While efforts have been made to ensure the information contained in this document is accurate, complete and current, it may contain technical inaccuracies, omissions and typographical errors. Diodes does not warrant that information contained in this document is error-free and Diodes is under no obligation to update or otherwise correct this information. Notwithstanding the foregoing, Diodes reserves the right to make modifications, enhancements, improvements, corrections or other changes without further notice to this document and any product described herein. This document is written in English but may be translated into multiple languages for reference. Only the English version of this document is the final and determinative format released by Diodes.
8. Any unauthorized copying, modification, distribution, transmission, display or other use of this document (or any portion hereof) is prohibited. Diodes assumes no responsibility for any losses incurred by the customers or users or any third parties arising from any such unauthorized use.

Copyright © 2021 Diodes Incorporated

[www.diodes.com](http://www.diodes.com)