

THIS DRAWING IS UNPUBLISHED. RELEASED FOR PUBLICATION
 © COPYRIGHT - By - ALL RIGHTS RESERVED.

LOC		DIST		REVISIONS			
P	LTR	DESCRIPTION		DATE	DWN	APVD	
		D1	ECR-12-005726	27MAR12	RK	MY	

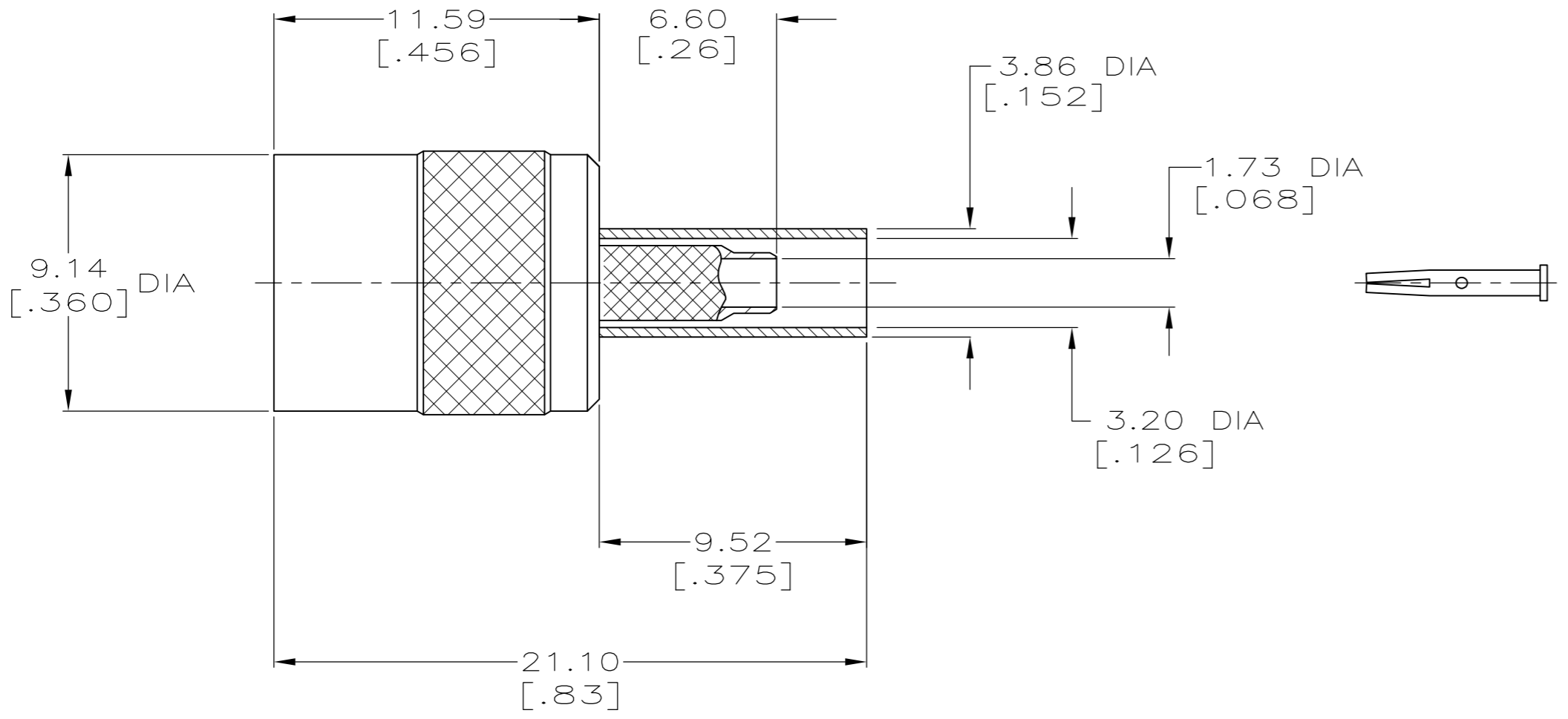

1. MATERIALS:
 BODIES...BRASS PER QQ-B-626
 INNER AND OUTER CONTACTS...
 BERYLLIUM COPPER PER QQ-C-576
 DIELECTRIC...PTFE PER ASTM D1710
 FERRULE...ANNEALED COPPER PER QQ-C-576
2. FINISH:
 CENTER CONTACT...GOLD PER MIL-G-45204
 OTHER METAL PARTS...NICKEL PER QQ-N-290
3. FINISH:
 CENTER AND OUTER CONTACT...GOLD PER MIL-G-45204
 OTHER METAL PARTS...NICKEL PER QQ-N-290

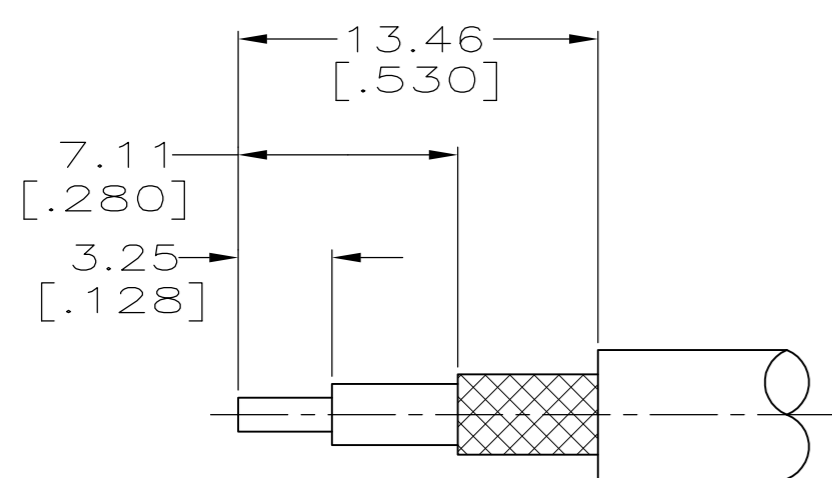

RECOMMENDED STRIP LENGTHS
 SCALE NTS

B	58483-1	.128	HX4-1637	4	K699	2	RG 179,187	414618-2
B	58483-1	.128	HX4-1637	4	K699	3	RG 179,187	414618-1
POSITION LETTER	TE DIE SET	HEX SIZE	DANIELS DIE SET	SELECTOR NUMBER	DANIELS POSITIONER	NOTES	CABLE	PART NUMBER
TE PRO-CRIMPER FOR BRAID CRIMP		M 22520/5-01 FOR BRAID CRIMP		M 22520/2-01 FOR CONTACT CRIMP				

TOOLING INFORMATION

THIS DRAWING IS A CONTROLLED DOCUMENT.		DWN	B. WERNER	13/JUL/93	 TE Connectivity									
DIMENSIONS: mm [INCHES]		CHK	J. MCLEOD	13/JUL/93										
TOLERANCES UNLESS OTHERWISE SPECIFIED:		APVD	J. MCLEOD	13/JUL/93										
0 PLC ± - 1 PLC ± - 2 PLC ± .25 [.010] 3 PLC ± .13 [.005] 4 PLC ± - ANGLES ± -		PRODUCT SPEC	NAME											
MATERIAL SEE NOTES		FINISH	SEE NOTES		WEIGHT	-	SIZE	A2	CAGE CODE	00779	DRAWING NO	C=414618	RESTRICTED TO	-
		CUSTOMER DRAWING		SCALE	5:1	SHEET	1 OF 1	REV	D1					