

SPECIFICATION FOR AUTOMOTIVE SPEAKER

Customer	
Customer P/N	
Bestar Model Name	BMS3650C-LF
Product No.	133309
Issue No.	BS/TES01.857A
Issue Date	07/08/30

Approval:

- 1.Characteristics
- 2.Notice
- 3.Dimension
- 4.Bill of Material
- 5.Reliability Test
- 6.Packing
- 7.History change record

Drawn by	Checked by	Approved by	Customer approved
丁小军	莫丽丽	张秀琴	

For conform to the European Union Directive on the Restriction of Hazardous Substances(RoHS), this type of productions forbid use all the hazardous substances as follow:

Lead
Cadmium
Mercury
Hexavalent chromium
Polybrominated biphenyls (PBB)
Polybrominated diphenyl ethers (PBDE)



BESTAR ELECTRONICS INDUSTRY CO.,LTD
No.199 HuangHe West Road.New district,changzhou,
jiangsu Province,P.R.China
Tel:86-519-88222567 Fax:86-519-88222551
[Http:www.be-star.com](http://www.be-star.com)
E-mail: wu@be-star.com, info@be-star.com

BMS3650C-LF

1. Characteristic

1.1 Electrical and Mechanical Characteristics



1	Rated input	1W
2	Maximum input	1.5W
3	Resonance Frequency	540 ± 150Hz
4	Frequency Response	350...6000Hz
5	Impedance(at 1500Hz)	50ohm ± 15%
6	Output SPL	min79dB (12V DC power special circuit 30cm)
7	Buzzes & Rattles	must be normal at sine wave7.07V
8	Magnet	Nd-Fe-B
9	Diaphragm	PEI Film
10	Operation temperature	-40 ° C...+85° C
11	Storage temperature	-40 ° C...+85° C

2. Notice

2.1 Storage Condition

The products should be stored in the room ,where the temperature/humidity is stable. And avoid such places where there are large temperature changes. Please store the products at the following conditions:

Temperature: -10 to + 40°C Humidity: 15 to 85% R.H.

2.2 Expire Date on Storage

Expire date (Shelf life) of the products is six months after delivered under the conditions of a sealed and an unopened package. Please use the products within six months after delivered.

If you store the products for a long time (more than six months), use carefully because the products may be degraded in the solderability and/or rusty. Please confirm solderability and characteristics for the products regularly.

2.3 Notice on Product Storage

(1) Please do not store the products in a chemical atmosphere (Acids, Alkali, Bases, Organic gas, Sulfides and so on), because the characteristics may be reduced at quality, and/or be degraded in the solderability due to the storage in a chemical atmosphere.

(2) Please use the products immediately after the package is opened, because the characteristics may be reduced at quality, and/or be degraded in the solderability due to storage under the poor condition.

This print and information there in are proprietary to Bestar Electronics Industry Co., Ltd. and shall not be used in whole or in part without its written content

				Date:	07/08/30	BMS3650C-LF	
				Drawn by:	丁小军		
A	07/08/30	丁小军		Checked by:	莫丽丽	Speaker	
Rev.	Date	Drawn	Note	Approved by:	张秀琴		
BESTAR ELECTRONICS INDUSTRY CO.,LTD						DRG NO: BS/TES01.857A	Page:1 of 6
www.be-star.com wu@be-star.com							

BMS3650C-LF

3.Dimension

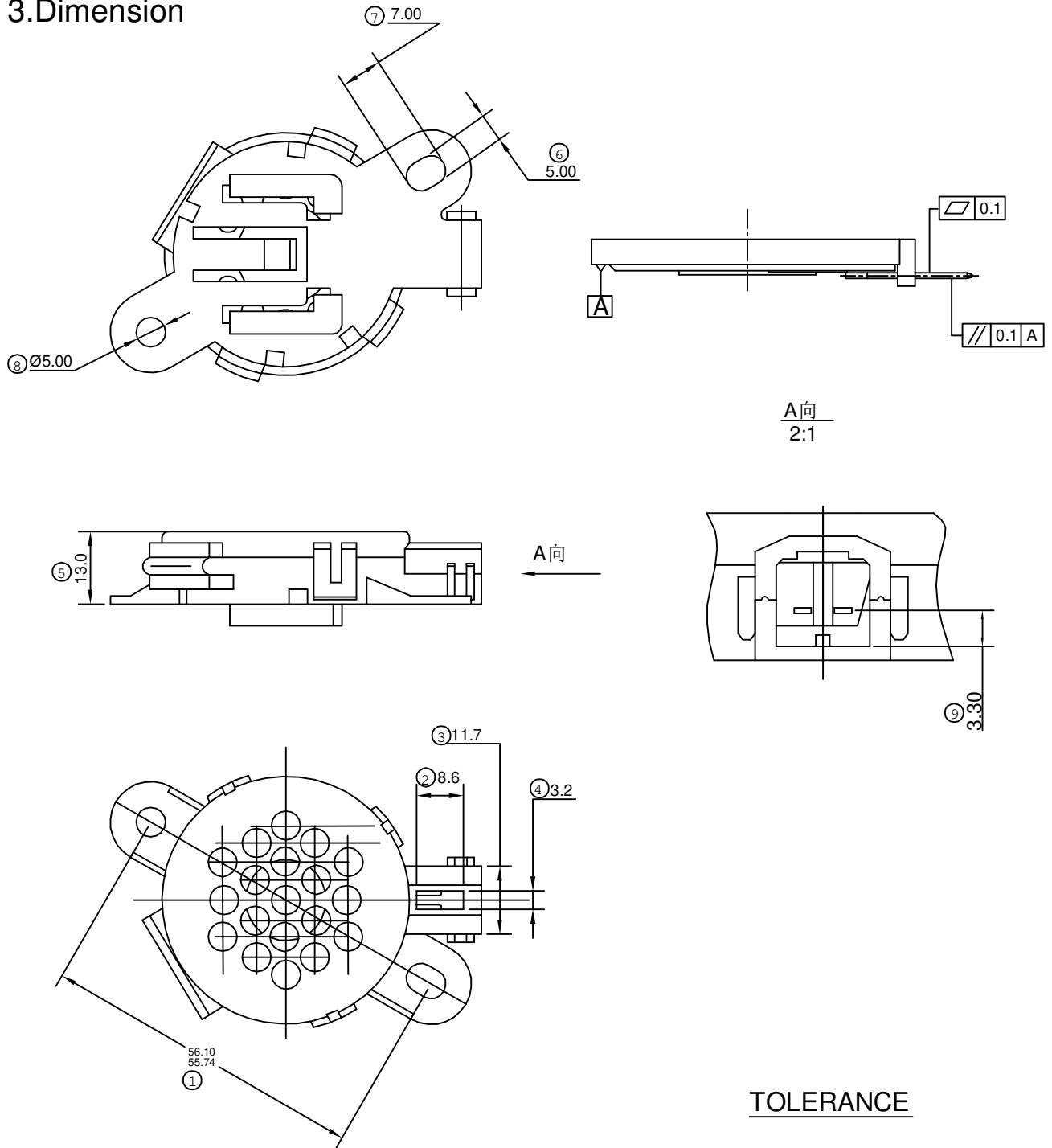

TOLERANCE

.XX=±0.1
.X =±0.2

This print and information there in are proprietary to Bestar Electronics Industry Co., Ltd. and shall not be used in whole or in part without its written content

				Date:	07/08/30	BMS3650C-LF	
				Drawn by:	丁小军		
A	A	07/08/30	丁小军	Checked by:	莫丽丽	Speaker	
Rev.	Date	Drawn	Note	Approved by:	张秀琴		
BESTAR ELECTRONICS INDUSTRY CO.,LTD						DRG NO: BS/TES01.857A	Page:2 of 6
www.be-star.com wu@be-star.com							

BMS3650C-LF

4. Bill of Material

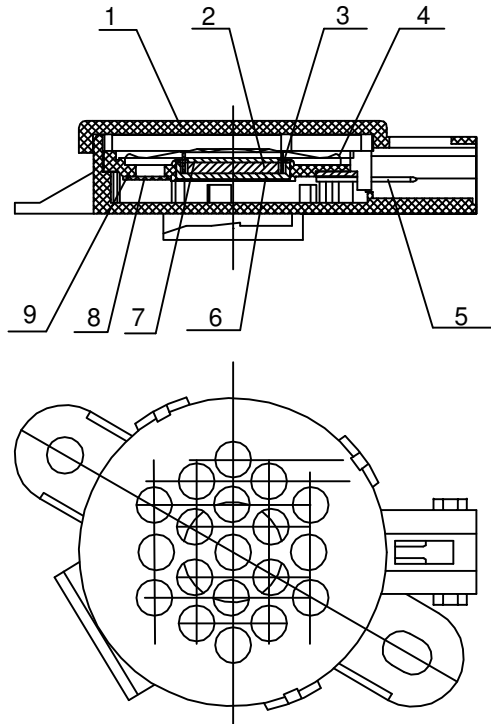

9	Frame	PBT
8	Mesh	SILK
7	Piece	SPCC
6	Magnet bowl	SPCC
5	Pin	BrassY68
4	Diaphragm	PEI
3	Voice Coil	φ0.05Cu
2	Magnet	N38H
1	Housing	PP
No	Parts Name	Material

This print and information there in are proprietary to Bestar Electronics Industry Co., Ltd. and shall not be used in whole or in part without its written content

				Date:	07/08/30	BMS3650C-LF	
				Drawn by:	丁小军		
A	07/08/30	丁小军		Checked by:	莫丽丽	Speaker	
Rev.	Date	Drawn	Note	Approved by:	张秀琴		
BESTAR ELECTRONICS INDUSTRY CO.,LTD						DRG NO: BS/TES01.857A	Page:3 of 6
www.be-star.com wu@be-star.com							

BMS3650C-LF

5. Reliability test

- 5.1 Life Test/Load test/temperature cycling
- | | |
|------------------------|-------------------------|
| Lower temperature | -40 ° C |
| upper temperature | +85 ° C |
| Dwell time | 30 Min each temperature |
| Duration of whole test | 240 h |
- dynamic operation with maximum rated voltage
- 5.2 Heat Test
- | | |
|-------------|------------|
| Temperature | +85 ° C± 2 |
| Duration | 96hrs |
- 5.3 Cold Test
- | | |
|-------------|------------|
| Temperature | -40 ° C± 2 |
| Duration | 96hrs |
- 5.4 Moisture Test
- | | |
|-------------|------------|
| Temperature | +85 ° C± 2 |
| Humidity | 85%RH |
| Duration | 56days |
- Recovery conditions: Climatic condition standard atmospheric
Ventilation time 1 h
- 5.5 Temperature shock
- | | |
|---|---------|
| Low temperature | -40 ° C |
| Upper temperature | +85 ° C |
| Dwell time each temperature | 30min. |
| Transfer time from lower to upper temperature | < 10s |
| Number of cycles | 100 |
- 5.6 Vibration Test
- | | |
|----------------------|-------------------|
| Range of frequency 1 | 10 to 55Hz |
| Amplitude | +/-0.75mm |
| Range of frequency 2 | 55 to 2000Hz |
| Amplitude | 10g |
| Frequency sweep | 1 oct/min |
| Duration | 2h each of 3 axis |
- 5.7 Drop test
- Drop the speaker contained in normal box on to the board 20mm thick 10 times from the height of 1.2m

After each test of 5.2 to 5.3, speakers should be measured after 6hrs exposed in normal temperature.

After each test, performance should be satisfied with spec.

This print and information there in are proprietary to Bestar Electronics Industry Co., Ltd. and shall not be used in whole or in part without its written content

				Date:	07/08/30	BMS3650C-LF
				Drawn by:	丁小军	
A	A	07/08/30	丁小军	Checked by:	莫丽丽	Speaker
Rev.	Date	Drawn	Note	Approved by:	张秀琴	
BESTAR ELECTRONICS INDUSTRY CO.,LTD						DRG NO: BS/TES01.857A
www.be-star.com wu@be-star.com						Page:4 of 6

BMS3650C-LF

6. Packing

6.1 Packing Drawing

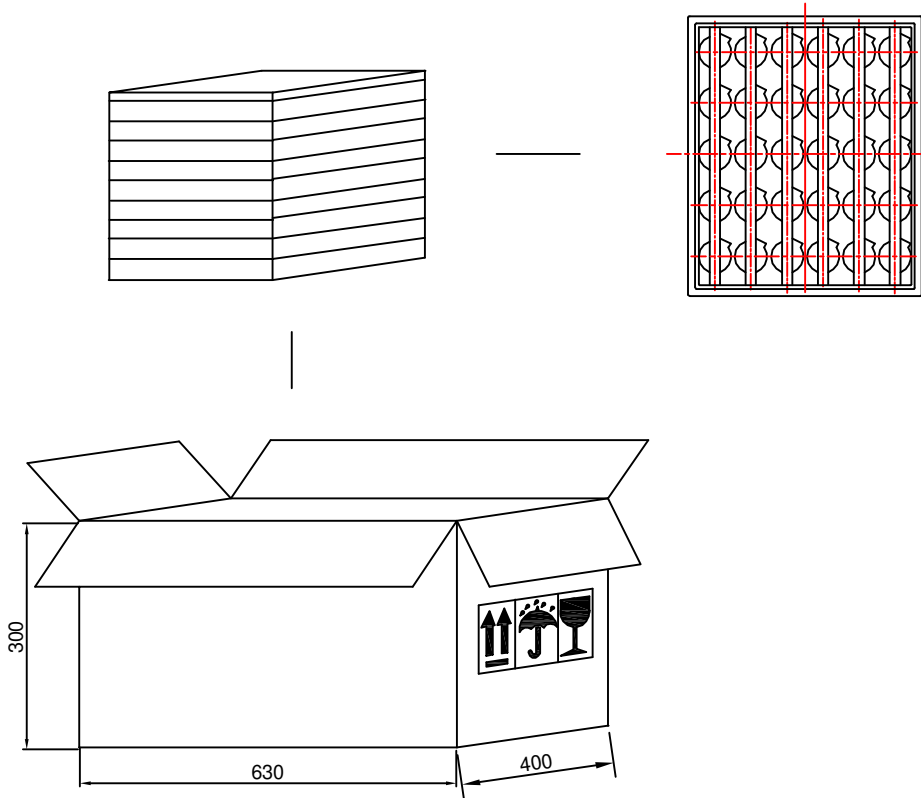

6.2 packing quantity

- 1) 30pcs per tray,
- 2) 18pcs tray per carton
- 3) 540pcs per carton,
- 4) carton size: 63X40X30cm

This print and information there in are proprietary to Bestar Electronics Industry Co., Ltd. and shall not be used in whole or in part without its written content

				Date:	07/08/30	BMS3650C-LF
				Drawn by:	丁小军	
A	07/08/30	丁小军		Checked by:	莫丽丽	Speaker
Rev.	Date	Drawn	Note	Approved by:	张秀琴	
BESTAR ELECTRONICS INDUSTRY CO.,LTD						DRG NO: BS/TES01.857A
						Page:5 of 6

