

SI-3000KD Series

Surface-Mount, Low Current Consumption, Low Dropout Voltage

Features

- Compact surface-mount package (TO263-5)
- Output current: 1.0A
- Low dropout voltage: $V_{DIF} \leq 0.6V$ (at $I_o = 1.0A$)
- Low circuit current consumption: $I_q \leq 350 \mu A$ (600 μA for SI-3010KD, SI-3050KD)
- Low circuit current at output OFF: $I_q (OFF) \leq 1 \mu A$
- Built-in overcurrent, thermal protection circuits
- Compatible with low ESR capacitors (SI-3012KD and SI-3033KD)

Absolute Maximum Ratings

($T_a=25^\circ C$)

Parameter	Symbol	Ratings		Unit
		SI-3012KD/3033KD	SI-3010KD/3050KD	
DC Input Voltage	V_{IN}	17	35 ^{*1}	V
Output Control Terminal Voltage	V_c	V_{IN}		V
DC Output Current	I_o	1.0		A
Power Dissipation	P_D^{*2}	3		W
Junction Temperature	T_j	-30 to +125		$^\circ C$
Storage Temperature	T_{stg}	-30 to +125		$^\circ C$
Thermal Resistance (Junction to Ambient Air)	θ_{j-a}	33.3		$^\circ C/W$
Thermal Resistance (Junction to Case)	θ_{j-c}	3		$^\circ C/W$

*1: A built-in input-overvoltage-protection circuit shuts down the output voltage at the Input Overvoltage Shutdown Voltage of the electrical characteristics.

*2: When mounted on glass-epoxy board of 1600mm² (copper laminate area 100%).

Applications

- Secondary stabilized power supply (local power supply)

Electrical Characteristics 1 (Low Input Voltage type compatible with low ESR output capacitor)

($T_a=25^\circ C, V_c=2V$, unless otherwise specified)

Parameter	Symbol	Ratings						Unit
		SI-3012KD (Variable type)			SI-3033KD			
		min.	typ.	max.	min.	typ.	max.	
Input Voltage	V_{IN}	2.4 ^{*3}		4	3		4	V
Output Voltage (Reference Voltage for SI-3012KD)	$V_o (V_{ADJ})$	1.24	1.28	1.32	3.234	3.300	3.366	V
Line Regulation	ΔV_{OLINE}	$V_{IN}=3.3V, I_o=10mA$			$V_{IN}=5V, I_o=10mA$			mV
	Conditions	$V_{IN}=3.3 \text{ to } 8V, I_o=10mA (V_o=2.5V)$			$V_{IN}=5 \text{ to } 10V, I_o=10mA$			
Load Regulation	ΔV_{LOAD}	40			50			mV
	Conditions	$V_{IN}=3.3V, I_o=0 \text{ to } 1A (V_o=2.5V)$			$V_{IN}=5V, I_o=0 \text{ to } 1A$			
Dropout Voltage	V_{DIF}	0.4			0.4			V
	Conditions	$I_o=0.5A (V_o=2.5V)$			$I_o=0.5A$			
	Conditions	$I_o=1A (V_o=2.5V)$			$I_o=1A$			
Quiescent Circuit Current	I_q	350			350			μA
Conditions		$V_{IN}=3.3V, I_o=0A, V_c=2V, R_2=2.4k\Omega$			$V_{IN}=5V, I_o=0A, V_c=2V$			
Circuit Current at Output OFF	$I_q (OFF)$	1			1			μA
Conditions		$V_{IN}=3.3V, V_c=0V$			$V_{IN}=5V, V_c=0V$			
Temperature Coefficient of Output Voltage	$\Delta V_o/\Delta T_a$	± 0.3			± 0.3			mV/ $^\circ C$
Conditions		$T_j=0 \text{ to } 100^\circ C (V_o=2.5V)$			$T_j=0 \text{ to } 100^\circ C$			
Ripple Rejection	R_{REJ}	55			55			dB
Conditions		$V_{IN}=3.3V, f=100 \text{ to } 120Hz, I_o=0.1A (V_o=2.5V)$			$V_{IN}=5V, f=100 \text{ to } 120Hz, I_o=0.1A$			
Overcurrent Protection Starting Current ^{*1}	I_{s1}	1.1			1.1			A
Conditions		$V_{IN}=3.3V$			$V_{IN}=5V$			
V_c Terminal	Control Voltage (Output ON) ^{*2}	2			2			V
	Control Voltage (Output OFF)	V_c, I_H			0.8			
	Control Current (Output ON)	I_c, I_H			40			
	Control Current (Output OFF)	I_c, I_L			-5			
Conditions		$V_c=2V$			$V_c=2V$			
Conditions		$V_c=0V$			$V_c=0V$			

*1: I_{s1} is specified at the 5% drop point of output voltage V_o under the condition of Output Voltage parameter.

*2: Output is OFF when the output control terminal (V_c terminal) is open. Each input level is equivalent to LS-TTL level. Therefore, the device can be driven directly by LS-TTLs.

*3: Refer to the Dropout Voltage parameter.

*4: $V_{IN} (max)$ and $I_o (max)$ are restricted by the relation $P_D = (V_{IN} - V_o) \times I_o$. Please calculate these values referring to the Copper laminate area vs. Power dissipation data.

■Electrical Characteristics 2 (High Input Voltage Type)

Parameter	Symbol	Ratings						Unit	
		SI-3010KD (Variable type)			SI-3050KD				
		min.	typ.	max.	min.	typ.	max.		
Input Voltage	V_{IN}	2.4 ^{*1}		27 ^{*5}	^{*1}			V	
Output Voltage (Reference Voltage V_{ADJ} for SI-3010KD)	V_O (V_{ADJ})	0.98	1.00	1.02	4.90	5.00	5.10	V	
	Conditions	$V_{IN}=7V, I_O=10mA$			$V_{IN}=7V, I_O=10mA$				
Line Regulation	ΔV_{OLINE}			30			30	mV	
	Conditions	$V_{IN}=6$ to 11V, $I_O=10mA$ ($V_O=5V$)			$V_{IN}=6$ to 11V, $I_O=10mA$				
Load Regulation	ΔV_{OLOAD}			75			75	mV	
	Conditions	$V_{IN}=7V,$ $I_O=0$ to 1A ($V_O=5V$)			$V_{IN}=7V, I_O=0$ to 1A				
Dropout Voltage	V_{DIF}			0.3			0.3	V	
	Conditions	$I_O=0.5A$ ($V_O=5V$)			$I_O=0.5A$				
	Conditions	$I_O=1A$ ($V_O=5V$)			$I_O=1A$				
Quiescent Circuit Current	I_q			600			600	∞A	
	Conditions	$V_{IN}=7V, I_O=0A, V_C=2V$ $R_2=10k\Omega$			$V_{IN}=7V, I_O=0A,$ $V_C=2V$				
Circuit Current at Output OFF	I_q (OFF)			1			1	∞A	
	Conditions	$V_{IN}=7V, V_C=0V$			$V_{IN}=7V, V_C=0V$				
Temperature Coefficient of Output Voltage	$\Delta V_O/\Delta T_a$		± 0.5			± 0.5		mV/ $^{\circ}C$	
	Conditions	$T_j=0$ to 100 $^{\circ}C$ ($V_O=5V$)			$T_j=0$ to 100 $^{\circ}C$				
Ripple Rejection	RREJ		75			75		dB	
	Conditions	$V_{IN}=7V,$ $f=100$ to 120Hz, $I_O=0.1A$ ($V_O=5V$)			$V_{IN}=7V,$ $f=100$ to 120Hz, $I_O=0.1A$				
Overcurrent Protection Starting Current ^{*2}	I_{S1}	1.1			1.1			A	
	Conditions	$V_{IN}=7V$			$V_{IN}=7V$				
Vc Terminal	Control Voltage (Output ON) ^{*3}	V_C, I_H	2.0		2.0			V	
	Control Voltage (Output OFF) ^{*3}	V_C, I_L			0.8		0.8	V	
	Control Current (Output ON)	I_C, I_H			40		40	∞A	
		Conditions	$V_C=2V$			$V_C=2V$			
	Control Current (Output OFF)	I_C, I_L	-5	0		-5	0		∞A
	Conditions	$V_C=0V$			$V_C=0V$				
Input Overvoltage Shutdown Voltage	V_{OVP}	33			26			V	
	Conditions	$I_O=10mA$			$I_O=10mA$				

*1: Refer to the Dropout Voltage parameter.

*2: I_{S1} is specified at the 5% drop point of output voltage V_O under the condition of Output Voltage parameter.

*3: Output is OFF when the output control terminal (V_C terminal) is open. Each input level is equivalent to LS-TTL level. Therefore, the device can be driven directly by LS-TTLs.

*4: SI-3010KD, SI-3050KD, cannot be used in the following applications because the built-in foldback-type overcurrent protection may cause errors during start-up stage.

(1) Constant current load (2) Positive and negative power supply (3) Series-connected power supply (4) V_O adjustment by raising ground voltage

*5: V_{IN} (max) and I_O (max) are restricted by the relation $P_b = (V_{IN} - V_O) \times I_O$. Please calculate these values referring to the Copper laminate area vs. Power dissipation data as shown hereinafter.

■External Dimensions (TO263-5)

(unit : mm)

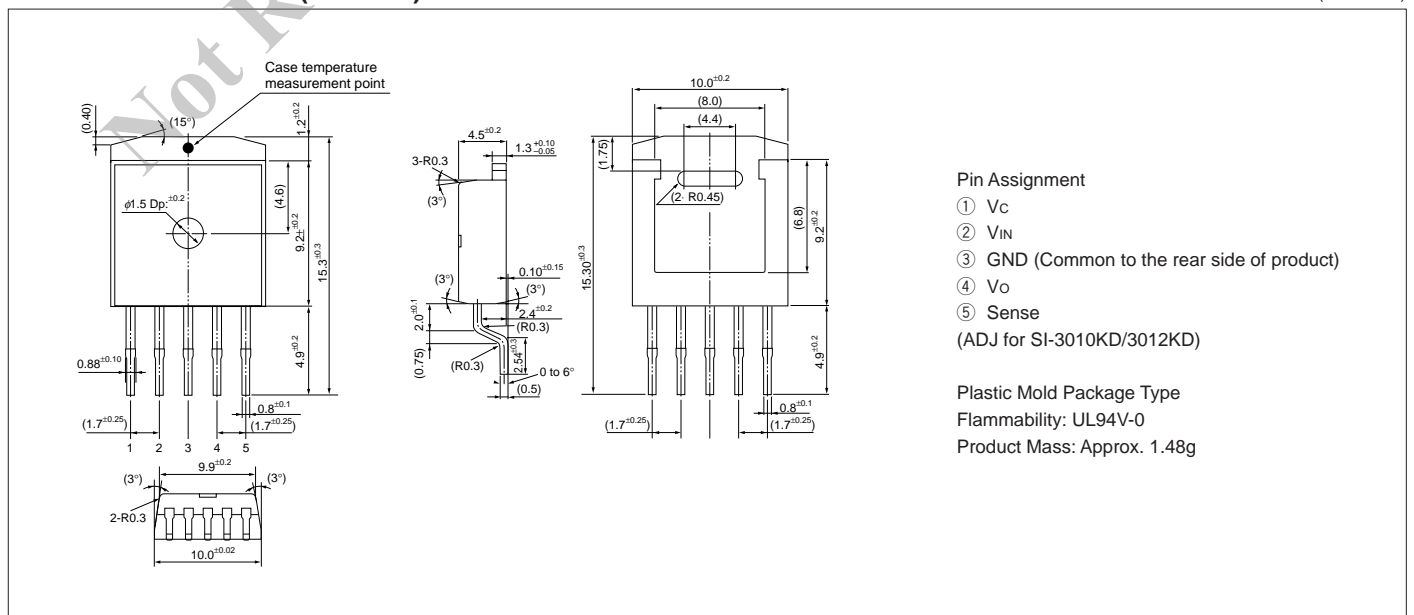

■Block Diagram

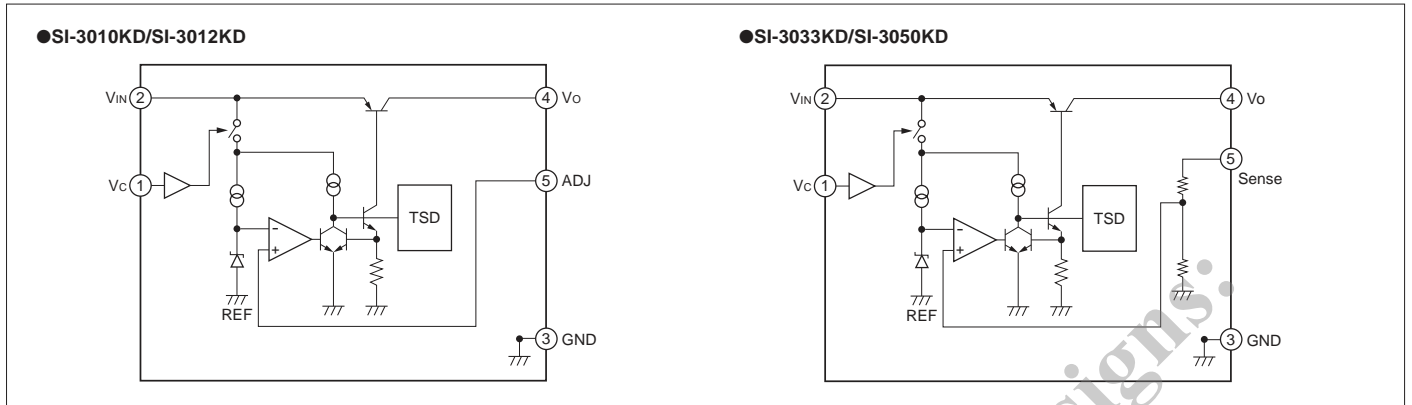

■Typical Connection Diagram

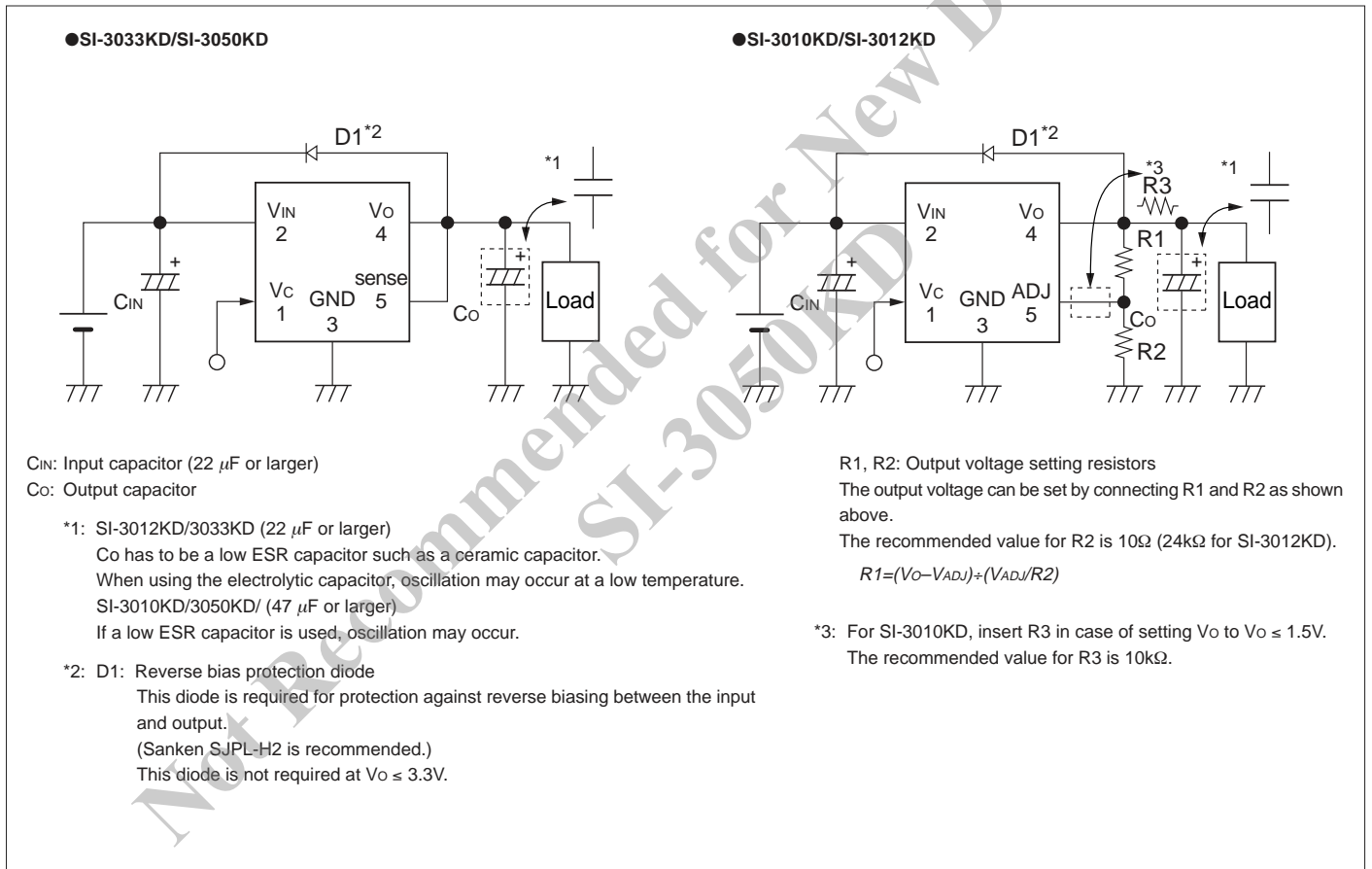

■Reference Data

Copper Laminate Area (on Glass-Epoxy Board) vs. Thermal Resistance (from Junction to Ambient Temperature) (Typical Value)

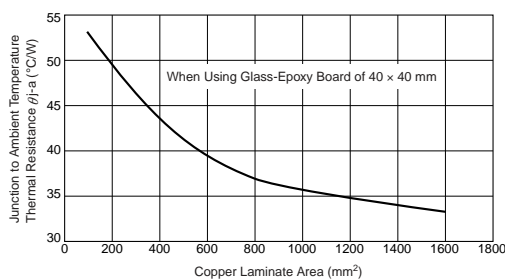

- A higher heat radiation effect can be achieved by enlarging the copper laminate area connected to the inner frame to which a monolithic ICs is mounted.
- Obtaining the junction temperature
 Measure the case temperature T_c with a thermocouple, etc. Then, substitute this value in the following formula to obtain the junction temperature.

$$T_j = P_D \times \theta_{j-c} + T_c \quad (\theta_{j-c} = 3^{\circ}\text{C/W}) \quad P_D = (V_{IN} - V_o) \cdot I_{OUT}$$