

Revision level		Revision Record	Changed	Date	Approved	Date
part	drawing					
-	03	See ECN 011032	AAC	05/12/08	K.A.C.	05/12/08

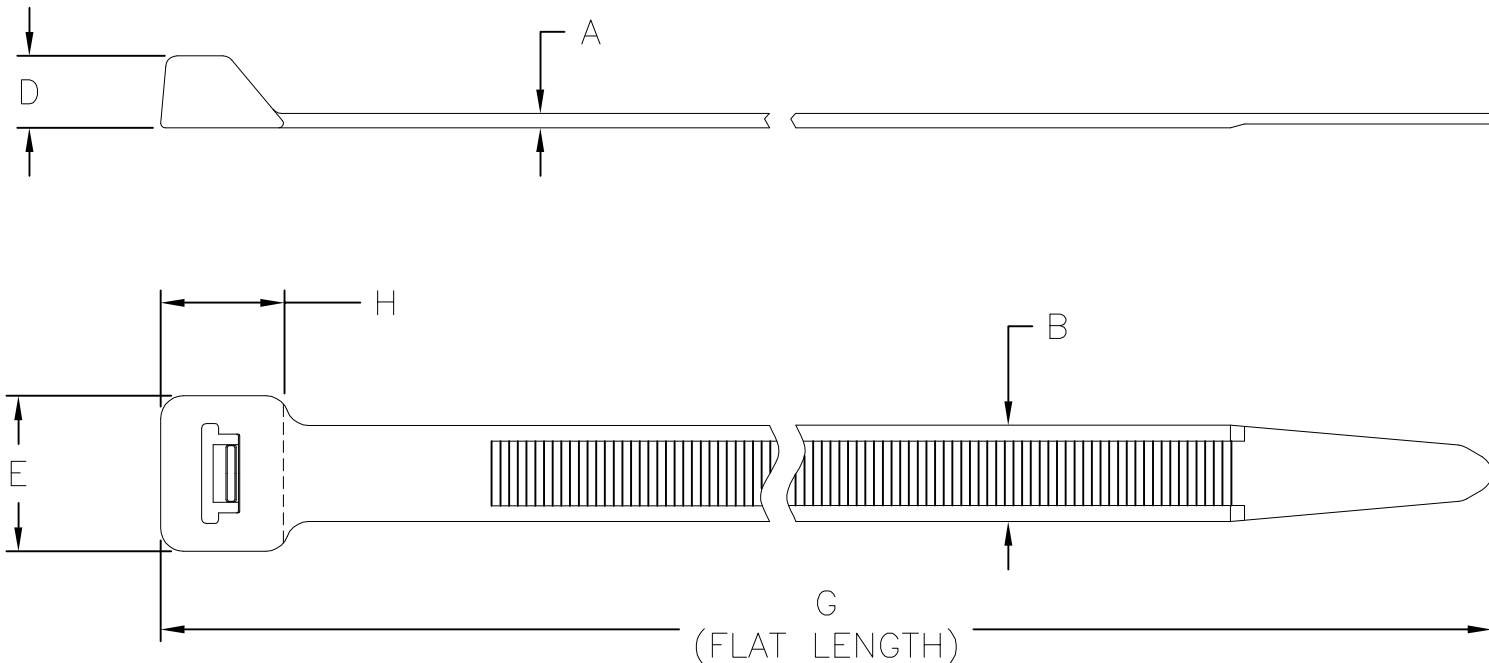

PRODUCT CODE DESCRIPTION

SR255S\_HIHSUV

COLOR

(CONSULT FACTORY FOR AVAILABLE COLORS)

G (FLAT LENGTH)

03

03

Product Code	Cable Range (mm)	Material	A	B	D	E	G	H	Min Loop Tensile Strength (newtons)
SR255S_HIHSUV	13 to 50	PA66HIHSUV	1.8±0.2	12.6±0.3	9.3 ±0.3	20.0 ±0.5	225.0 ±5.0	15.5 ±1.2	1115

SEE CHART

Material

Dimension tolerances unless otherwise specified

- .XXXX = ± .0130
- .XXX = ± .130
- .XX = ± .30
- .X = ± .8
- ∠ = ± 0.5 °

Dimension Units mm

PERFORMANCE SPECIFICATION

ACAD MECH  
2008

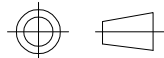

Drawn  
Approved

KDP  
K.A.C.

02/14/01  
05/12/08

Scale 1:1

Computer File Number  
CT\CST\2252007\_03  
Phase: Production

ALL PROPRIETARY RIGHTS IN THE SUBJECT MATTER SHOWN ON THIS DRAWING ARE EXCLUSIVE PROPERTY OF HELLERMANNNTYTON

**HellermannTyton**

7930 N. Faulkner Rd.  
Milwaukee, WI 53224  
Ph: (414) 355-1130  
Fx: (414) 362-8338

**SR255S**  
**250 LB CABLE TIE W/SUB-RELEASE**  
**WITHOUT BUCKLE MOUNT**

Drawing-No

**CT2252007CST**

Format

AH

Sheet 1 of 1