

| PART NUMBER | REV | FIRST USED |
|-------------|-----|------------|
| 687833-4 | C | 854400-1 |

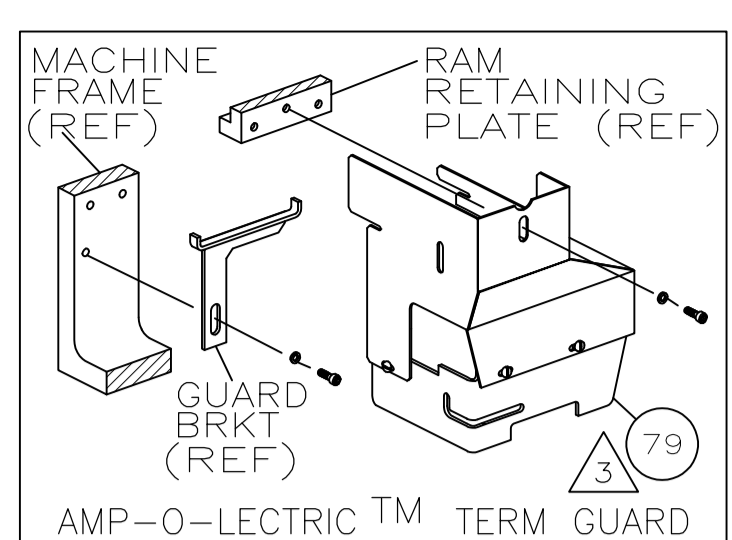

| TERMINAL NAME: FLANGED SPADE | |
|------------------------------|--|
| 40891-A | |
| 41495-A | |
| 42113-A | |
| TERM APPL SPEC 114-2084 | |

| CRIMPING DATA | | | |
|-----------------------------|--------------|--------------------|---------------------------------|
| PAD LTR | CRIMP HEIGHT | WIRE SIZE | |
| A | .120 ±.002 | 10 | |
| B | .108 ±.002 | 12 | |
| C | NOT | USED | |
| D | NOT | USED | |
| CRIMP | SIZE | TYPE | RANGE |
| WIRE | .180 | F | 12-10 |
| INSUL | - | - | - |
| FEED | .800 | APPL INST 408-8039 | SET UP GAGE 458638-1 LAYOUT 26A |
| WIRE STRIP LENGTH .235-.265 | | | |

| REVISIONS | | | |
|-----------|------|---------------|--------|
| LOC | DIST | DESCRIPTION | DATE |
| A | 66 | | |
| C | | ECR-09-014469 | 6-2009 |
| BY | MY | | GB |

-4 LEADMAKER & BENCH MODEL G MECH POST FEED

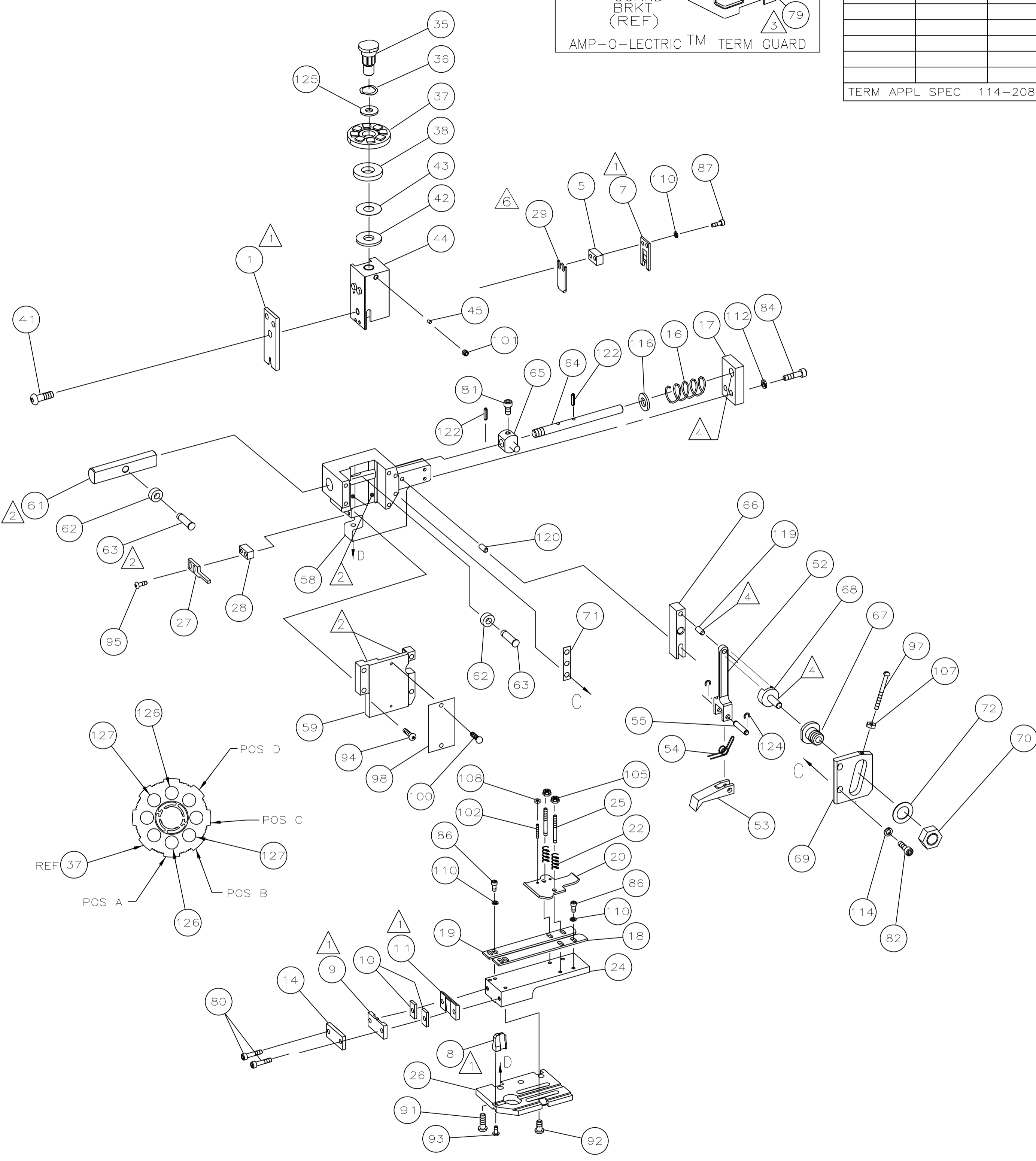

| REF | QTY | DESCRIPTION | ITEM NO |
|-------|-----|---------------------------------------|---------|
| REF - | | 22594-8 NUT, HEX | 70 |
| REF - | | 240628-1 PLATE, ADJ | 69 |
| REF - | | 240626-1 SHAFT, PIVOT | 68 |
| REF - | | 240633-1 BUSHING | 67 |
| REF - | | 455680-1 LEVER, INTERMEDIATE | 66 |
| REF - | | 240629-1 BLOCK, PIVOT | 65 |
| REF - | | 240632-2 SCR, ADJ | 64 |
| REF - | | 240659-3 PIN, CAM ROLLER | 63 |
| REF - | | 240658-1 CAM, ROLLER | 62 |
| REF - | | 454398-1 ROD, FEED | 61 |
| REF - | | 454220-1 CAP, RAM | 59 |
| REF - | | 453736-1 HOUSING | 58 |
| REF - | | 240624-1 PIN, FEED FINGER | 55 |
| REF - | | 691499-1 SPRING, FEED FINGER | 54 |
| REF - | | 240635-1 FINGER, FEED | 53 |
| REF - | | 240634-3 LEVER, TERMINAL | 52 |
| REF - | | 690501-4 CAM, POST FEED 1 5/8 ST | 47 |
| REF - | | 690191-1 PLUG, NYLON | 45 |
| REF - | | 455674-1 RAM | 44 |
| REF - | | 690125-1 WASHER, LAMINATED | 43 |
| REF - | | 1-690124-0 WASHER, RAM | 42 |
| REF - | | 7-21002-9 BOLT, CRIMPER(5/16-24x1.00) | 41 |
| REF - | | 690223-2 SPACER, INSULATION DISC | 38 |
| REF - | | 354777-1 WIRE DISC, PLASTIC | 37 |
| REF - | | 22480-5 WASHER, SPRING | 36 |
| REF - | | 690212-1 POST, RAM | 35 |
| REF - | | 458980-2 APPLICATOR, BASIC (SUB ASSY) | 32 |
| REF - | | 690759-1 TOOL, FLANGING | 29 |
| REF - | | 3-690451-2 SPACER, STRIPPER | 28 |
| REF - | | 240639-1 STRIPPER | 27 |
| REF - | | 455676-1 PLATE, BASE | 26 |
| REF - | | 22354-8 DRAG, STUD | 25 |
| REF - | | 455678-6 PLATE, STRIP GUIDE | 24 |
| REF - | | 4-22281-1 SPRING, DRAG | 22 |
| REF - | | 454177-1 DRAG, STOCK | 20 |
| REF - | | 458030-4 GUIDE, STRIP (REAR) | 19 |
| REF - | | 458031-4 GUIDE, STRIP (FRONT) | 18 |
| REF - | | 454178-1 GUIDE, FEED ROD | 17 |
| REF - | | 4-22284-9 SPRING, FEED RETURN | 16 |
| REF - | | 690783-1 PLATE, RETAINING | 14 |
| REF - | | 1-240644-1 PLATE, REAR SHEAR | 11 |
| REF - | | 1-240645-2 SPACER, SHEAR PLATE | 10 |
| REF - | | 690784-7 PLATE, FRONT SHEAR | 9 |
| REF - | | 240654-3 ANVIL | 8 |
| REF - | | 6-240651-7 BLADE, SLUG | 7 |
| REF - | | 4-240641-8 SPACER, SLUG BLADE | 5 |
| REF - | | 456428-2 CRIMPER, WIRE | 1 |

| QTY REQD | U/M | PART NO | DESCRIPTION | ITEM NO |
|----------|-----|------------|----------------------------------|---------|
| 2 | - | 7-354778-9 | PIN, WIRE DISC (.2890)B | 129 |
| 2 | - | 5-354778-0 | PIN, WIRE DISC (.2745)A | 126 |
| 1 | - | 986950-1 | WASHER, FLAT PRECISION | 125 |
| REF | - | 21045-3 | RING, RET" C" (Ø.187)FD PIN | 124 |
| REF | - | 5-21028-1 | PIN, STD SPRING (Ø.12)FD ADJ ROD | 123 |
| REF | - | 1-21030-7 | PIN, DOWEL (Ø.187x1.50)HSG | 122 |
| REF | - | 1-21030-1 | PIN, DOWEL (Ø.187x.50)LEVER | 121 |
| REF | - | 21899-4 | WASHER, FLAT (Ø5/16)SCR ADJ | 120 |
| REF | - | 21024-5 | WASHER, LOCK (NO.10)FD ADJ PL | 119 |
| REF | - | 21024-5 | WASHER, LOCK (NO.10)FD ROD GDE | 118 |
| 6 | - | 21024-4 | WASHER, LOCK (NO.8)SHEAR BL | 117 |
| 2 | - | 21018-4 | NUT, HEX (4-40)DRAG | 116 |
| REF | - | 21018-5 | NUT, HEX (6-32)FD ADJ PL | 115 |
| 2 | - | 21022-2 | NUT, HEX SL (8-32)DRAG STUD | 114 |
| 2 | - | 2-21006-6 | SCR, SKT SET (4-40x.62)DRAG | 113 |
| 1 | - | 21009-2 | SCR, SKT SET (1/4-20x.25)RAM | 112 |
| 2 | - | 21017-2 | SCR, DRIVE (#2x.19)ID PLATE | 111 |
| 1 | - | 1-21002-7 | SCR, BHC (6-32x.38)CAM | 110 |
| 1 | - | 461264-1 | PLATE, IDENTIFICATION | 109 |
| REF | - | 6-23715-5 | SCR, PAN HD (6-32x1.50)FEED ADJ | 108 |
| 2 | - | 2-21002-2 | SCR, BHC (8-32x.50)STRIPPER | 107 |
| REF | - | 2-21002-9 | SCR, BHC (10-32x.75)HSG CAP | 106 |
| 1 | - | 22733-8 | SCR, BHC (8-32x.38 LW)ANVIL | 105 |
| 4 | - | 3-21002-3 | SCR, BHC (1/4-20x.50)ST GD PL | 104 |
| REF | - | 2-22733-8 | SCR, BHC (1/4-20x.62)BASE PL | 103 |
| 2 | - | 2-21000-7 | SCR, SHC (8-32x.50)SLUG BLADE | 102 |
| 4 | - | 2-21000-6 | SCR, SHC (8-32x.38)STRIP GUIDE | 101 |
| REF | - | 3-21000-7 | SCR, SKT CAP (10-32x.75)FD GDE | 100 |
| REF | - | 3-21000-6 | SCR, SKT CAP (10-32x.62)FD ADJ P | 99 |
| REF | - | 3-21000-4 | SCR, SKT CAP (10-32x.38)PIVOT BL | 98 |
| 2 | - | 3-21002-0 | SCR, SKT CAP (10-32x.88)SH PL | 97 |
| REF | - | 455745-1 | GUARD, WINDOW | 96 |
| REF | - | 458109-1 | WASHER, FLAT (SPECIAL) | 95 |
| REF | - | 690517-1 | SPACER | 94 |

- 1 RECOMMENDED SPARE PARTS.
- 2 GREASE LIGHTLY.
- 3 GUARD MUST BE IN PLACE WHEN OPERATING APPLICATOR IN A BENCH MACHINE.
- 4 LUBRICATE DAILY USING NO. 20 MACHINE OIL.
- 5. ITEMS WITH QTY OF REF SPECIFIED (EXCEPT ITEMS 78 AND 79) ARE USED ON ITEM 32.
- 6 ADJUST ITEM 29 TO ACHIEVE PROPER BEND WHEN CHANGING WIRE SIZES.

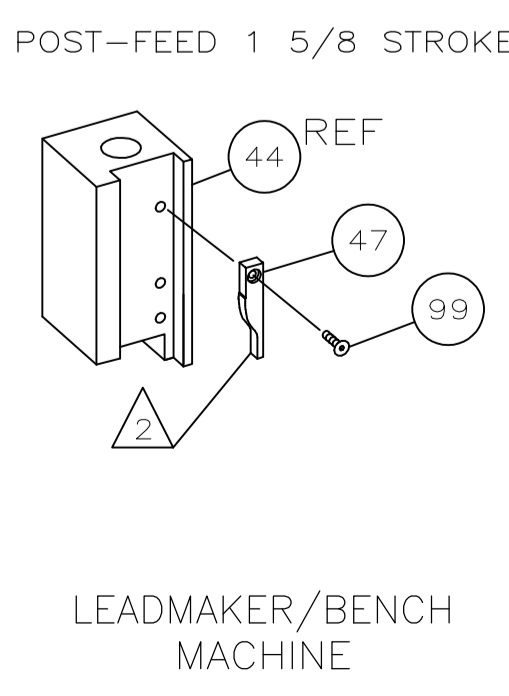

THIS DRAWING IS A CONTROLLED DOCUMENT. DIMENSIONS: INCHES. TOLERANCES UNLESS OTHERWISE SPECIFIED: 0 PLC ±.0005, 1 PLC ±.0008, 2 PLC ±.0010, 3 PLC ±.0015, 4 PLC ±.0020. ANGLES: UNLESS OTHERWISE SPECIFIED. MATERIAL: FINISH: Tyco Electronics Corporation, Harrisburg, PA 17105-3608. NAME: END FEED HDM APPLICATOR. SIZE: A1. CASE CODE: 00779. DRAWING NO: 687833-4. WEIGHT: RESTRICTED TO: CUSTOMER DRAWING. SCALE: SHEET 1 OF 1. REV C.