

## GENERAL DESCRIPTION

The 841602 is an optimized PCIe and sRIO clock generator. The device uses a 25MHz parallel crystal to generate 100MHz and 125MHz clock signals, replacing solutions requiring multiple oscillator and fanout buffer solutions. The device has excellent phase jitter (< 1ps rms) suitable to clock components requiring precise and low-jitter PCIe or sRIO or both clock signals. Designed for telecom, networking and industrial applications, the 841602 can also drive the high-speed sRIO and PCIe SerDes clock inputs of communication processors, DSPs, switches and bridges.

## FEATURES

- Two differential clock outputs: configurable for PCIe (100MHz) and sRIO (125MHz) clock signals
- Selectable crystal oscillator interface, 25MHz, 18pF parallel resonant crystal or LVCMOS/LVTTL single-ended reference clock input
- Supports the following output frequencies: 100MHz or 125MHz
- VCO: 500MHz
- PLL bypass and output enable
- PCI Express (2.5Gb/s) and Gen 2 (5 Gb/s) jitter compliant
- RMS phase jitter, 125MHz, using a 25MHz crystal: (1.875MHz – 20MHz): 0.45ps (typical)
- Full 3.3V power supply mode
- -40°C to 85°C ambient operating temperature
- Available in lead-free (RoHS 6) package

## BLOCK DIAGRAM

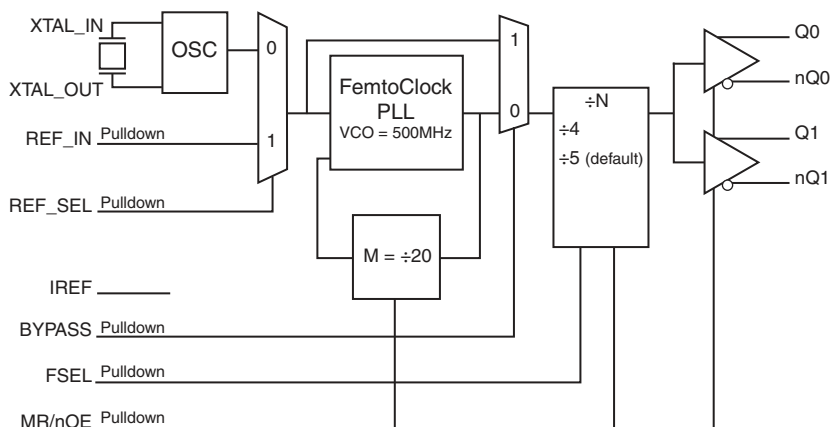

## PIN ASSIGNMENT

REF_SEL	1	28	V <sub>DDA</sub>
REF_IN	2	27	BYPASS
V <sub>DD</sub>	3	26	IREF
GND	4	25	FSEL
XTAL_IN	5	24	V <sub>DD</sub>
XTAL_OUT	6	23	nQ1
MR/nOE	7	22	Q1
V <sub>DD</sub>	8	21	nQ0
nc	9	20	Q0
nc	10	19	GND
nc	11	18	nc
nc	12	17	nc
GND	13	16	nc
V <sub>DD</sub>	14	15	nc

**841602**

**28-Lead TSSOP**

6.1mm x 9.7mm x 0.925mm  
package body  
**G Package**  
Top View

**TABLE 1. PIN DESCRIPTIONS**

Number	Name	Type		Description
1	REF_SEL	Input	Pulldown	Reference select. Selects the input reference source. LVCMOS/LVTTL interface levels. See Table 3D.
2	REF_IN	Input	Pulldown	LVCMOS/LVTTL PLL reference clock input.
3, 8, 14, 24	V <sub>DD</sub>	Power		Core supply pins.
4, 13, 19	GND	Power		Power supply ground.
5, 6	XTAL_IN, XTAL_OUT	Input		Parallel resonant crystal interface. XTAL_OUT is the output, XTAL_IN is the input.
7	MR/nOE	Input	Pulldown	Active HIGH master reset. Active LOW output enable. When logic HIGH, the internal dividers are reset and the outputs are in high impedance (HiZ). When logic LOW, the internal dividers and the outputs are enabled. Asynchronous function. LVCMOS/LVTTL interface levels. See Table 3C.
9, 10, 11, 12, 15, 16, 17, 18	nc	Unused		No connect.
20, 21	Q0, nQ0	Output		Differential output pair. PCI Express interface levels.
22, 23	Q1, nQ1	Output		Differential output pair. PCI Express interface levels.
25	FSEL	Input	Pulldown	Output frequency select pin. LVCMOS/LVTTL interface levels. See Table 3A.
26	IREF	Output		HCSL current reference resistor output. An external fixed precision resistor (475Ω) from this pin to ground provides a reference current used for differential current-mode Qx/nQx clock outputs.
27	BYPASS	Input	Pulldown	Selects PLL operation/PLL bypass operation. Asynchronous function. LLVCMOS/LVTTL interface levels. See Table 3B.
28	V <sub>DDA</sub>	Power		Analog supply pin.

NOTE: *Pulldown* refers to internal input resistors. See Table 2, Pin Characteristics, for typical values.

**TABLE 2. PIN CHARACTERISTICS**

Symbol	Parameter	Test Conditions	Minimum	Typical	Maximum	Units
C <sub>IN</sub>	Input Capacitance			4		pF
R <sub>PULLDOWN</sub>	Input Pulldown Resistor			51		kΩ

**TABLE 3A. FSEL FUNCTION TABLE (f<sub>ref</sub> = 25MHz)**

Input		Outputs
FSEL	N	Q0:7/nQ0:7
0	5	VCO/5 (100MHz) PCIe (default)
1	4	VCO/4 (125MHz) sRIO

**TABLE 3B. BYPASS FUNCTION TABLE**

Input	
BYPASS	PLL Configuration
0	PLL enabled (default)
1	PLL bypassed (f <sub>OUT</sub> = f <sub>REF</sub> ÷ N)

**TABLE 3C. MR/nOE FUNCTION TABLE**

Input	
MR/nOE	Function
0	Outputs enabled (default)
1	Device reset, outputs disabled (high-impedance)

**TABLE 3D. REF\_SEL FUNCTION TABLE**

Input	
REF_SEL	Input Reference
0	XTAL (default)
1	REF_IN

**ABSOLUTE MAXIMUM RATINGS**

Supply Voltage, $V_{DD}$	4.6V
Inputs, $V_I$	-0.5V to $V_{DD} + 0.5V$
Outputs, $V_O$	-0.5V to $V_{DD} + 0.5V$
Package Thermal Impedance, $\theta_{JA}$	64.5°C/W (0 mps)
Storage Temperature, $T_{STG}$	-65°C to 150°C

NOTE: Stresses beyond those listed under Absolute Maximum Ratings may cause permanent damage to the device. These ratings are stress specifications only. Functional operation of product at these conditions or any conditions beyond those listed in the *DC Characteristics* or *AC Characteristics* is not implied. Exposure to absolute maximum rating conditions for extended periods may affect product reliability.

**TABLE 4A. POWER SUPPLY DC CHARACTERISTICS,  $V_{DD} = 3.3V \pm 5\%$ ,  $T_A = -40^\circ C$  TO  $85^\circ C$** 

Symbol	Parameter	Test Conditions	Minimum	Typical	Maximum	Units
$V_{DD}$	Core Supply Voltage		3.135	3.3	3.465	V
$V_{DDA}$	Analog Supply Voltage		$V_{DD} - 0.15$	3.3	$V_{DD}$	V
$I_{DD}$	Power Supply Current				87	mA
$I_{DDA}$	Analog Supply Current				15	mA

**TABLE 4B. LVCMOS / LVTTTL DC CHARACTERISTICS,  $V_{DD} = 3.3V \pm 5\%$ ,  $T_A = -40^\circ C$  TO  $85^\circ C$** 

Symbol	Parameter	Test Conditions	Minimum	Typical	Maximum	Units
$V_{IH}$	Input High Voltage		2		$V_{DD} + 0.3$	V
$V_{IL}$	Input Low Voltage		-0.3		0.8	V
$I_{IH}$	Input High Current	REF_IN, REF_SEL, BYPASS, MR/nOE, FSEL			150	$\mu A$
$I_{IL}$	Input Low Current	REF_IN, REF_SEL, BYPASS, MR/nOE, FSEL	-5			$\mu A$

**TABLE 5. CRYSTAL CHARACTERISTICS**

Parameter	Test Conditions	Minimum	Typical	Maximum	Units
Mode of Oscillation		Fundamental			
Frequency			25		MHz
Equivalent Series Resistance (ESR)				50	$\Omega$
Shunt Capacitance				7	pF

NOTE: Characterized using an 18pF parallel resonant crystal.

**TABLE 6. AC CHARACTERISTICS,  $V_{DD} = 3.3V \pm 5\%$ ,  $T_A = -40^\circ C$  TO  $85^\circ C$** 

Symbol	Parameter	Test Conditions	Minimum	Typical	Maximum	Units
$f_{MAX}$	Output Frequency	VCO/5		100		MHz
		VCO/4		125		MHz
$t_{jit}(\emptyset)$	RMS Phase Jitter (Random); NOTE 1	100MHz, (1.875MHz - 20MHz)		0.40		ps
		125MHz, (1.875MHz - 20MHz)		0.42		ps
$T_j$	Phase Jitter Peak-to-Peak; NOTE 2	100MHz, (1.2MHz – 50MHz), 10 <sup>6</sup> samples, 25MHz crystal input		14.50		ps
		125MHz, (1.2MHz – 62.5MHz), 10 <sup>6</sup> samples, 25MHz crystal input		13.67		ps
$T_{REFCLK\_HF\_RMS}$	Phase Jitter RMS; NOTE 3	100MHz, 10 <sup>6</sup> samples, 25MHz crystal input		1.41		ps rms
		125MHz, 10 <sup>6</sup> samples, 25MHz crystal input		1.25		ps rms
$t_{jit}(cc)$	Cycle-to-Cycle Jitter; NOTE 4				50	ps
$tsk(o)$	Output Skew; NOTE 4, 5				55	ps
Rise Edge Rate	Rising Edge Rate; NOTE 6, 7		0.6		4	V/ns
Fall Edge Rate	Falling Edge Rate; NOTE 6, 7		0.6		4	V/ns
$V_{RB}$	Ringback Voltage; NOTE 6, 8		-100		100	mV
$V_{MAX}$	Absolute Max. Output Voltage; NOTE 9, 10				1150	mV
$V_{MIN}$	Absolute Min. Output Voltage; NOTE 9, 11		-300			mV
$V_{CROSS}$	Absolute Crossing Voltage; NOTE 9, 12, 13		250		550	mV
$DV_{CROSS}$	Total Variation of $V_{CROSS}$ over all edges; NOTE 9, 12, 14				140	mV
odc	Output Duty Cycle; NOTE 6, 15		48		52	%
$T_{STABLE}$	Power-up Stable Clock Output; NOTE 6, 8		500			ps
$t_L$	PLL Lock Time				90	ms

NOTE: All specifications are taken at 100MHz and 125MHz.

NOTE 1: Please refer to the Phase Noise Plot.

NOTE 2: RMS jitter after applying system transfer function. See IDT Application Note, PCI Express Reference Clock Requirements. Maximum limit for PCI Express is 86ps peak-to-peak.

NOTE 3: RMS jitter after applying system transfer function. The pole frequencies for H1 and H2 for PCIe Gen 2 are 8-16MHz and 5-16MHz. See IDT Application Note, PCI Express Reference Clock Requirements. Maximum limit for PCI Express Generation 2 is 3.1ps rms.

NOTE 4: This parameter is defined in accordance with JEDEC Standard 65.

NOTE 5: Defined as skew between outputs at the same supply voltage and with equal load conditions.

Measured at the output differential cross points.

NOTE 6: Measurement taken from differential waveform.

NOTE 7: Measurement from -150mV to +150mV on the differential waveform (derived from Qx minus nQx).

The signal must be monotonic through the measurement region for rise and fall time. The 300mV measurement window is centered on the differential zero crossing. See Parameter Measurement Information Section.

NOTE 8:  $T_{STABLE}$  is the time the differential clock must maintain a minimum  $\pm 150mV$  differential voltage after rising/falling edges before it is allowed to drop back into the  $V_{RB} \pm 100$  differential range. See Parameter Measurement Information Section.

NOTE 9: Measurement taken from single ended waveform.

NOTE 10: Defined as the maximum instantaneous voltage including overshoot. See Parameter Measurement Information Section.

NOTE 11: Defined as the minimum instantaneous voltage including undershoot. See Parameter Measurement Information Section.

NOTE 12: Measured at crossing point where the instantaneous voltage value of the rising edge of Qx equals the falling edge of nQx.

See Parameter Measurement Information Section.

NOTE 13: Refers to the total variation from the lowest crossing point to the highest, regardless of which edge is crossing.

Refers to all crossing points for this measurement. See Parameter Measurement Information Section.

NOTE 14: Defined as the total variation of all crossing voltage of rising Qx and falling nQx. This is the maximum allowed variance in the  $V_{CROSS}$  for any particular system. See Parameter Measurement Information Section.

NOTE 15: Input duty cycle must be 50%.

### TYPICAL PHASE NOISE AT 100MHz

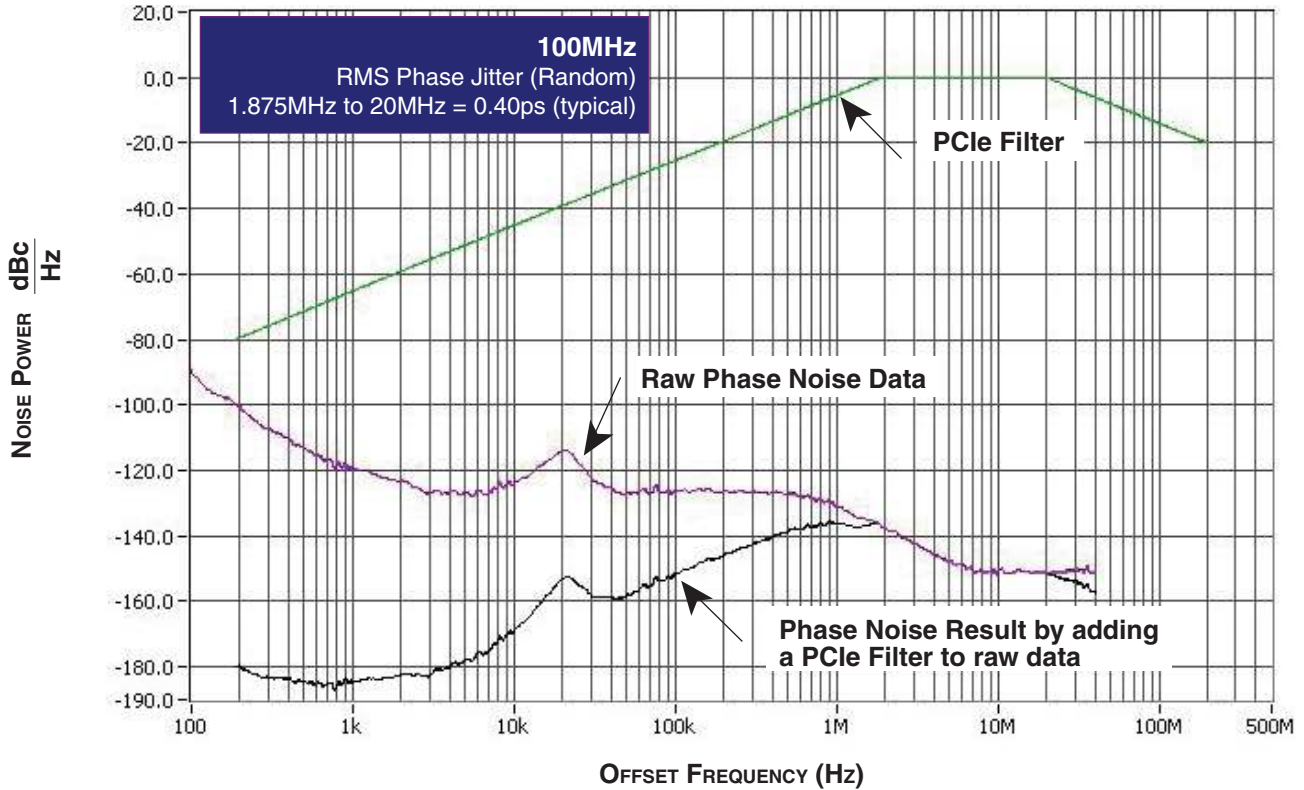

### TYPICAL PHASE NOISE AT 125MHz

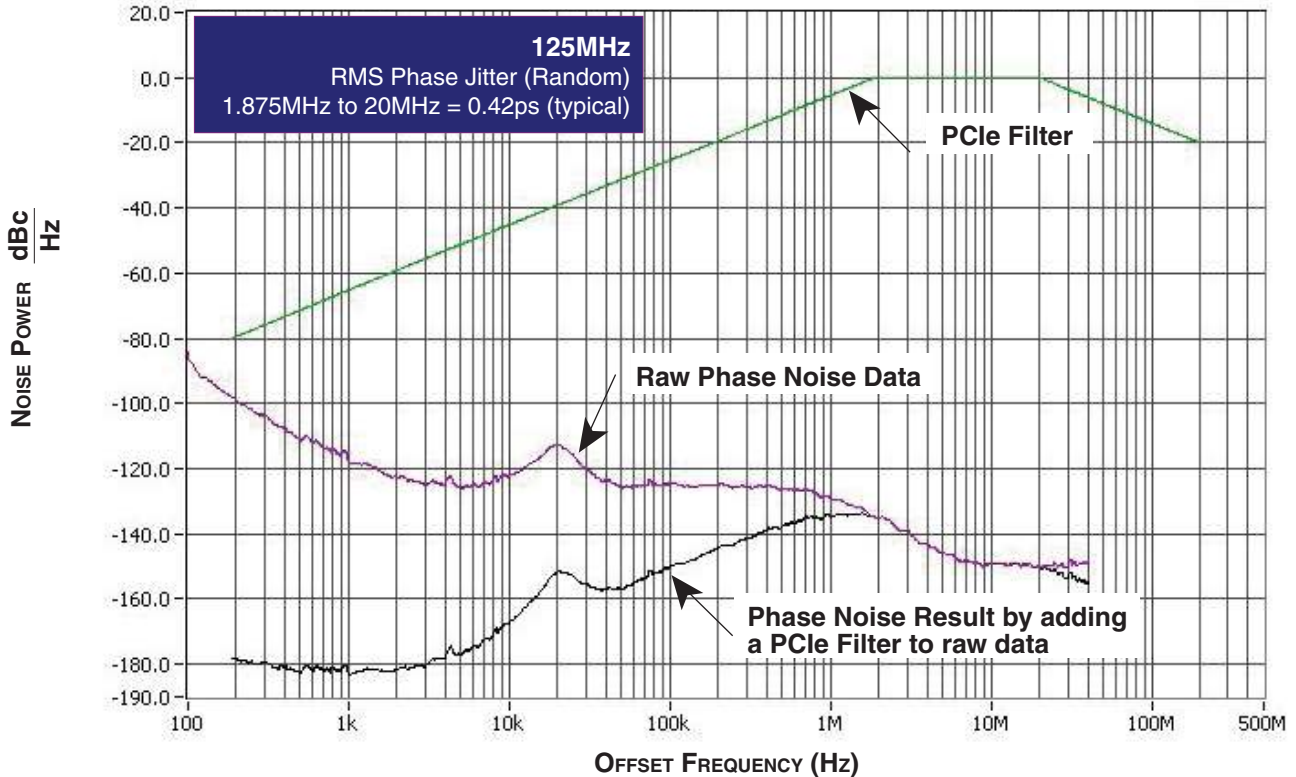

## PARAMETER MEASUREMENT INFORMATION

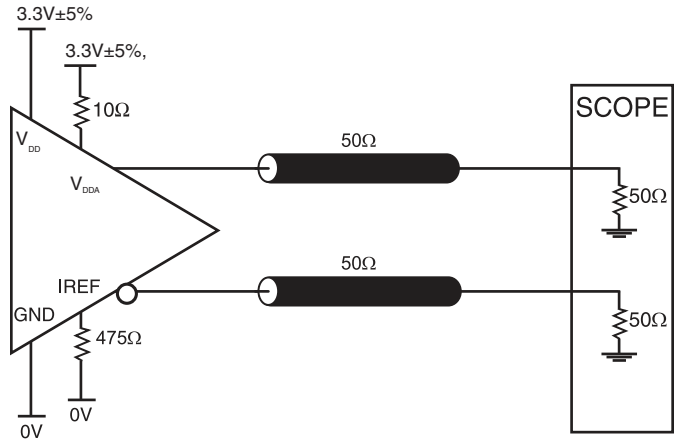
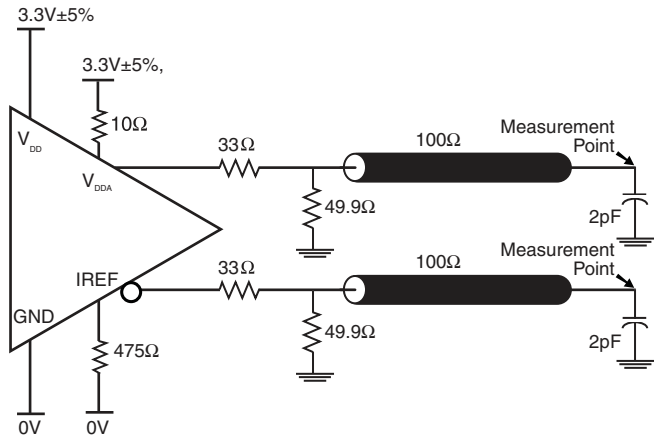

This load condition is used for  $I_{DD}$ ,  $t_{sk}(o)$ , and  $t_{jit}$  measurements.

3.3V HCSL OUTPUT LOAD AC TEST CIRCUIT

3.3V HCSL OUTPUT LOAD AC TEST CIRCUIT

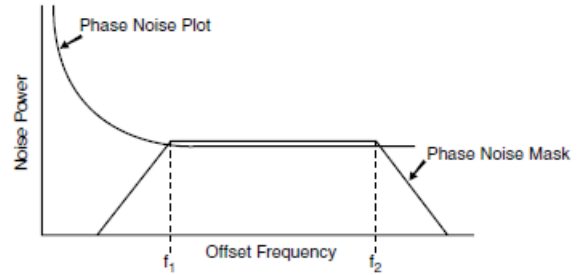
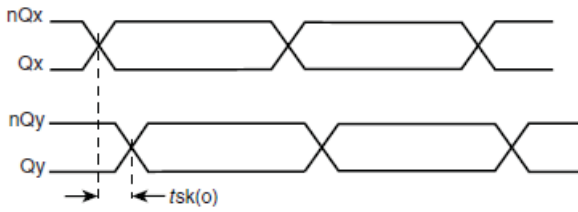

$$\text{RMS Jitter} = \sqrt{\text{Area Under the Masked Phase Noise Plot}}$$

OUTPUT SKEW

RMS PHASE JITTER

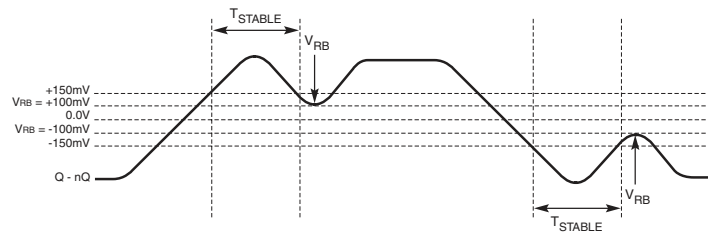

DIFFERENTIAL MEASUREMENT POINTS FOR RISE/FALL TIME

DIFFERENTIAL MEASUREMENT POINTS FOR RINGBACK

# PARAMETER MEASUREMENT INFORMATION, CONTINUED

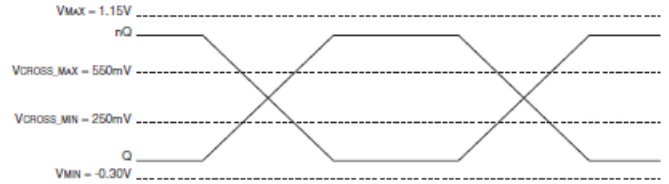
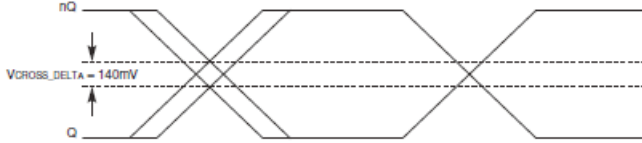

**SINGLE-ENDED MEASUREMENT POINTS FOR DELTA CROSS POINT**

**SINGLE-ENDED MEASUREMENT POINTS FOR ABSOLUTE CROSS POINT/SWING**

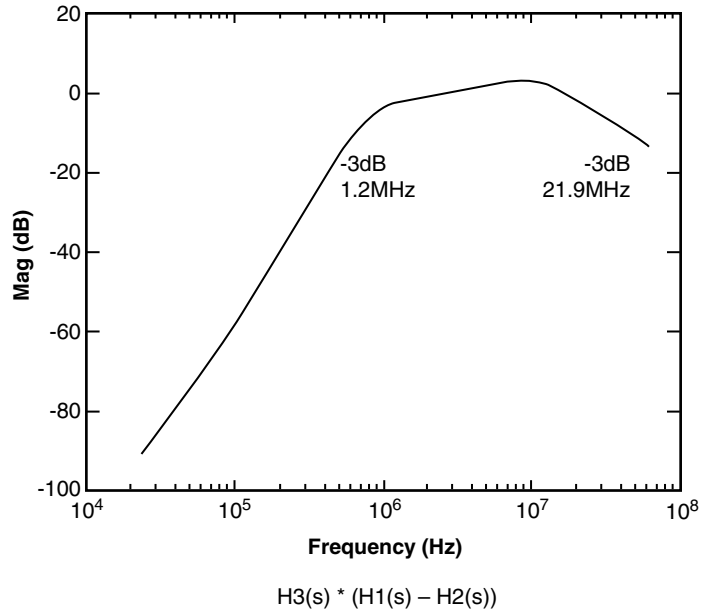
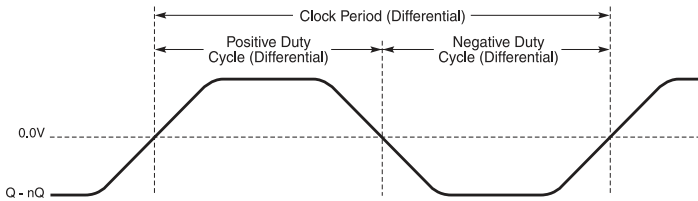

**DIFFERENTIAL MEASUREMENT POINTS FOR DUTY CYCLE PERIOD**

**COMPOSITE PCIe TRANSFER FUNCTION**

## APPLICATION INFORMATION

### POWER SUPPLY FILTERING TECHNIQUES

As in any high speed analog circuitry, the power supply pins are vulnerable to random noise. To achieve optimum jitter performance, power supply isolation is required. The 841602 provides separate power supplies to isolate any high switching noise from the outputs to the internal PLL.  $V_{DD}$  and  $V_{DDA}$  should be individually connected to the power supply plane through vias, and  $0.01\mu\text{F}$  bypass capacitors should be used for each pin. *Figure 1* illustrates this for a generic  $V_{DD}$  pin and also shows that  $V_{DDA}$  requires that an additional  $10\Omega$  resistor along with a  $10\mu\text{F}$  bypass capacitor be connected to the  $V_{DDA}$  pin.

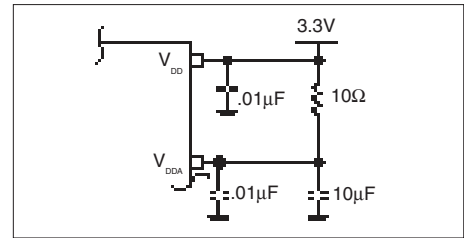

FIGURE 1. POWER SUPPLY FILTERING

### RECOMMENDATIONS FOR UNUSED INPUT AND OUTPUT PINS

#### INPUTS:

##### CRYSTAL INPUTS

For applications not requiring the use of the crystal oscillator input, both XTAL\_IN and XTAL\_OUT can be left floating. Though not required, but for additional protection, a  $1\text{k}\Omega$  resistor can be tied from XTAL\_IN to ground.

##### REF\_IN INPUT

For applications not requiring the use of the reference clock, it can be left floating. Though not required, but for additional protection, a  $1\text{k}\Omega$  resistor can be tied from the REF\_IN to ground.

##### LVC MOS CONTROL PINS

All control pins have internal pull-downs; additional resistance is not required but can be added for additional protection. A  $1\text{k}\Omega$  resistor can be used.

#### OUTPUTS:

##### DIFFERENTIAL OUTPUTS

All unused differential outputs can be left floating. We recommend that there is no trace attached. Both sides of the differential output pair should either be left floating or terminated.



### CRYSTAL INPUT INTERFACE

The 841602 has been characterized with 18pF parallel resonant crystals. The capacitor values shown in *Figure 2* below were

determined using a 25MHz, 18pF parallel resonant crystal and were chosen to minimize the ppm error.

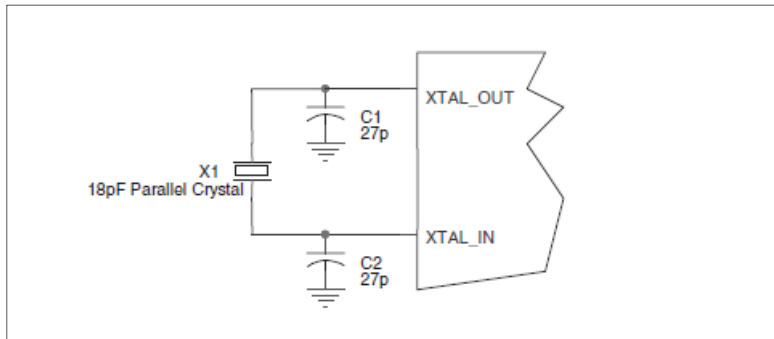

FIGURE 2. CRYSTAL INPUT INTERFACE

### LVC MOS TO XTAL INTERFACE

The XTAL\_IN input can accept a single-ended LVC MOS signal through an AC couple capacitor. A general interface diagram is shown in *Figure 3*. The XTAL\_OUT pin can be left floating. The input edge rate can be as slow as 10ns. For LVC MOS inputs, it is recommended that the amplitude be reduced from full swing to half swing in order to prevent signal interference with the power rail and to reduce noise. This configuration requires that the output

impedance of the driver ( $R_o$ ) plus the series resistance ( $R_s$ ) equals the transmission line impedance. In addition, matched termination at the crystal input will attenuate the signal in half. This can be done in one of two ways. First,  $R_1$  and  $R_2$  in parallel should equal the transmission line impedance. For most 50Ω applications,  $R_1$  and  $R_2$  can be 100Ω. This can also be accomplished by removing  $R_1$  and making  $R_2$  50Ω.

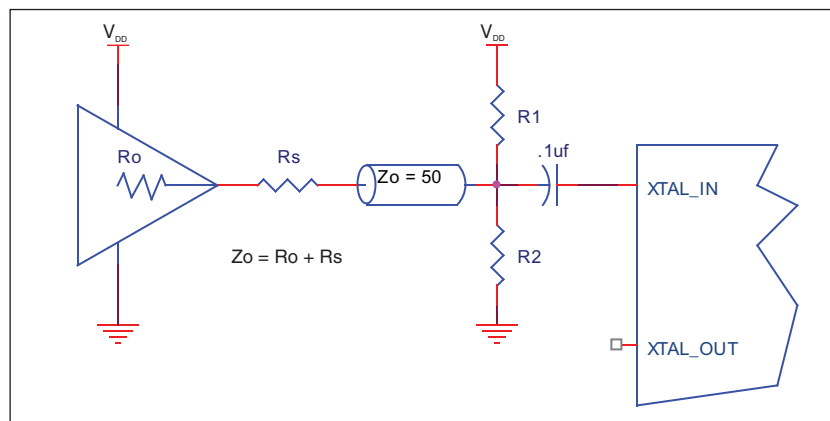
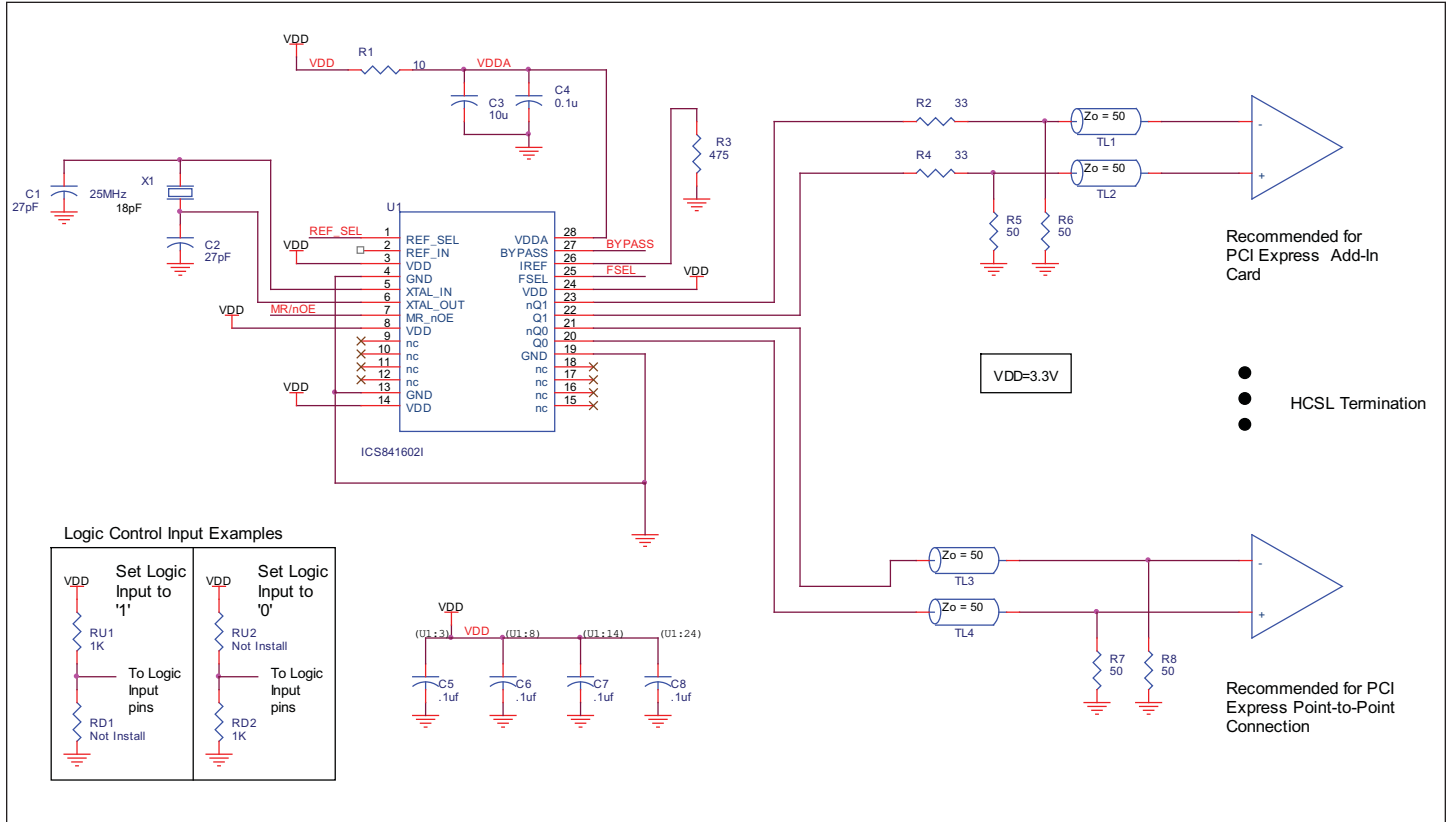

FIGURE 3. GENERAL DIAGRAM FOR LVC MOS DRIVER TO XTAL INPUT INTERFACE

**SCHEMATIC EXAMPLE**

Figure 4 shows an example of 841602 application schematic. In this example, the device is operated at  $V_{DD} = 3.3V$ . The 18pF parallel resonant 25MHz crystal is used. The  $C1 = 27pF$  and  $C2 = 27pF$  are recommended for frequency accuracy. For different board layout,

the  $C1$  and  $C2$  may be slightly adjusted for optimizing frequency accuracy. Two examples of HCSL terminations are shown in this schematic. The decoupling capacitors should be located as close as possible to the power pin.



**FIGURE 4. 841602 SCHEMATIC EXAMPLE**

**RECOMMENDED TERMINATION**

Figure 5A is the recommended termination for applications which require the receiver and driver to be on a separate PCB. All traces should be 50Ω impedance.

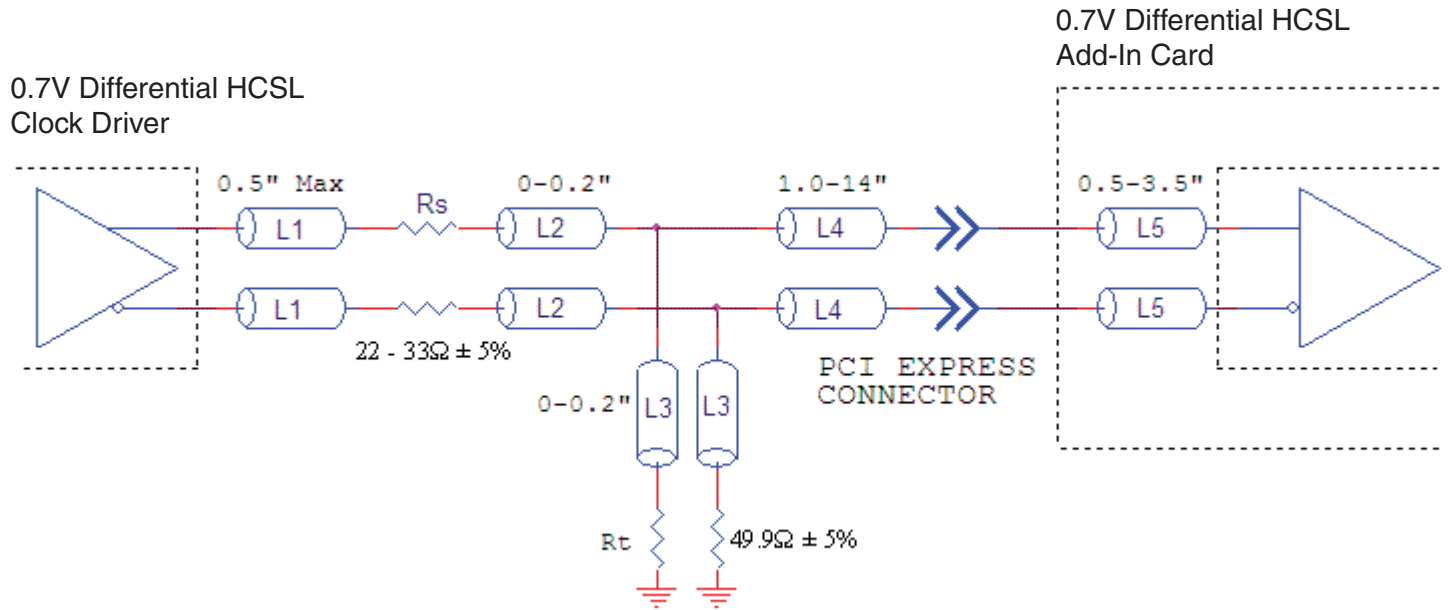

**FIGURE 5A. RECOMMENDED TERMINATION**

Figure 5B is the recommended termination for applications which require a point to point connection and contain the driver and

receiver on the same PCB. All traces should all be 50Ω impedance.

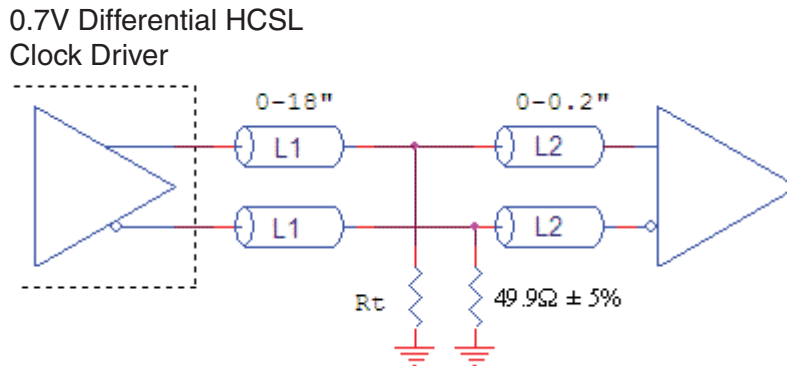

**FIGURE 5B. RECOMMENDED TERMINATION**

## POWER CONSIDERATIONS

This section provides information on power dissipation and junction temperature for the 841602. Equations and example calculations are also provided.

### 1. Power Dissipation.

The total power dissipation for the ICS41602I is the sum of the core power plus the analog plus the power dissipated in the load(s). The following is the power dissipation for  $V_{DD} = 3.3V + 5\% = 3.465V$ , which gives worst case results.

**NOTE:** Please refer to Section 3 for details on calculating power dissipated in the load.

- Power (core)<sub>MAX</sub> =  $V_{DD\_MAX} * (I_{DD\_MAX} + I_{DDA}) = 3.465V * (87mA + 15mA) = 353.43mW$
- Power (outputs)<sub>MAX</sub> = **44.5mW/Loaded Output pair**  
If all outputs are loaded, the total power is  $2 * 44.5mW = 89mW$

**Total Power**<sub>MAX</sub> (3.465V, with all outputs switching) =  $353.43mW + 89mW = 442.43mW$

### 2. Junction Temperature.

Junction temperature, T<sub>j</sub>, is the temperature at the junction of the bond wire and bond pad and directly affects the reliability of the device. The maximum recommended junction temperature for HiPerClockS™ devices is 125°C.

The equation for T<sub>j</sub> is as follows:  $T_j = \theta_{JA} * Pd\_total + T_A$

T<sub>j</sub> = Junction Temperature

$\theta_{JA}$  = Junction-to-Ambient Thermal Resistance

Pd<sub>total</sub> = Total Device Power Dissipation (example calculation is in Section 1 above)

T<sub>A</sub> = Ambient Temperature

In order to calculate junction temperature, the appropriate junction-to-ambient thermal resistance  $\theta_{JA}$  must be used. Assuming no air flow and a multi-layer board, the appropriate value is 64.5°C/W per Table 7 below.

Therefore, T<sub>j</sub> for an ambient temperature of 85°C with all outputs switching is:

$85^\circ C + 0.442W * 64.5^\circ C/W = 113.5^\circ C$ . This is well below the limit of 125°C.

This calculation is only an example. T<sub>j</sub> will obviously vary depending on the number of loaded outputs, supply voltage, air flow, and the type of board (single layer or multi-layer).

**TABLE 7. THERMAL RESISTANCE  $\theta_{JA}$  FOR 28-PIN TSSOP, FORCED CONVECTION**

$\theta_{JA}$ by Velocity (Meters per Second)			
	0	1	2.5
Multi-Layer PCB, JEDEC Standard Test Boards	64.5°C/W	60.4°C/W	58.5°C/W

3. Calculations and Equations.

The purpose of this section is to calculate power dissipation on the IC per HCSL output pair.

HCSL output driver circuit and termination are shown in *Figure 6*.

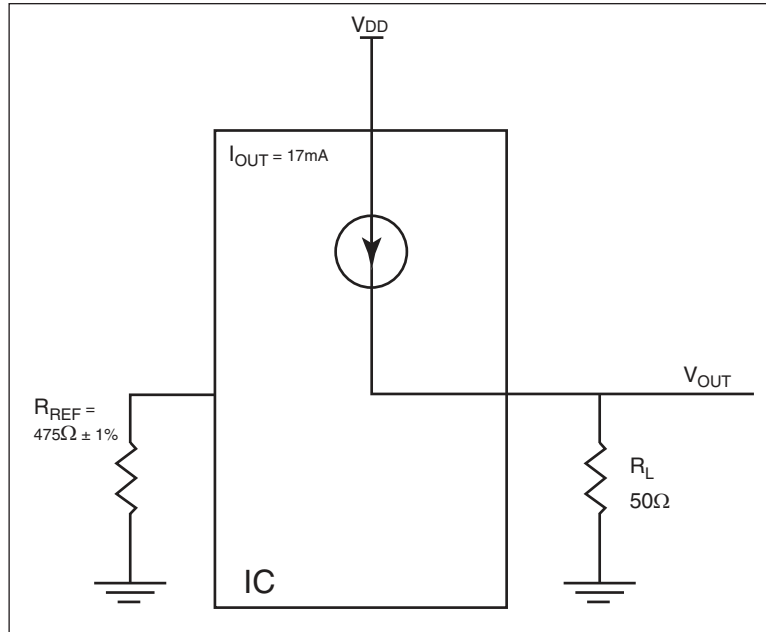

**FIGURE 6. HCSL DRIVER CIRCUIT AND TERMINATION**

HCSL is a current steering output which sources a maximum of 17mA of current per output. To calculate worst case on-chip power dissipation, use the following equations which assume a 50Ω load to ground.

The highest power dissipation occurs when  $V_{DD}$  is HIGH.

$$\begin{aligned} \text{Power} &= (V_{DD\_HIGH} - V_{OUT}) * I_{OUT}, \text{ since } V_{OUT} = I_{OUT} * R_L \\ &= (V_{DD\_HIGH} - I_{OUT} * R_L) * I_{OUT} \\ &= (3.465V - 17mA * 50\Omega) * 17mA \end{aligned}$$

Total Power Dissipation per output pair = **44.5mW**

## RELIABILITY INFORMATION

TABLE 8.  $\theta_{JA}$  VS. AIR FLOW TABLE FOR 28 LEAD TSSOP

$\theta_{JA}$  by Velocity (Meters per Second)

	0	1	2.5
Multi-Layer PCB, JEDEC Standard Test Boards	64.5°C/W	60.4°C/W	58.5°C/W

### TRANSISTOR COUNT

The transistor count for 841602 is: 2785

## PACKAGE OUTLINE & DIMENSIONS

PACKAGE OUTLINE - G SUFFIX FOR 28 LEAD TSSOP

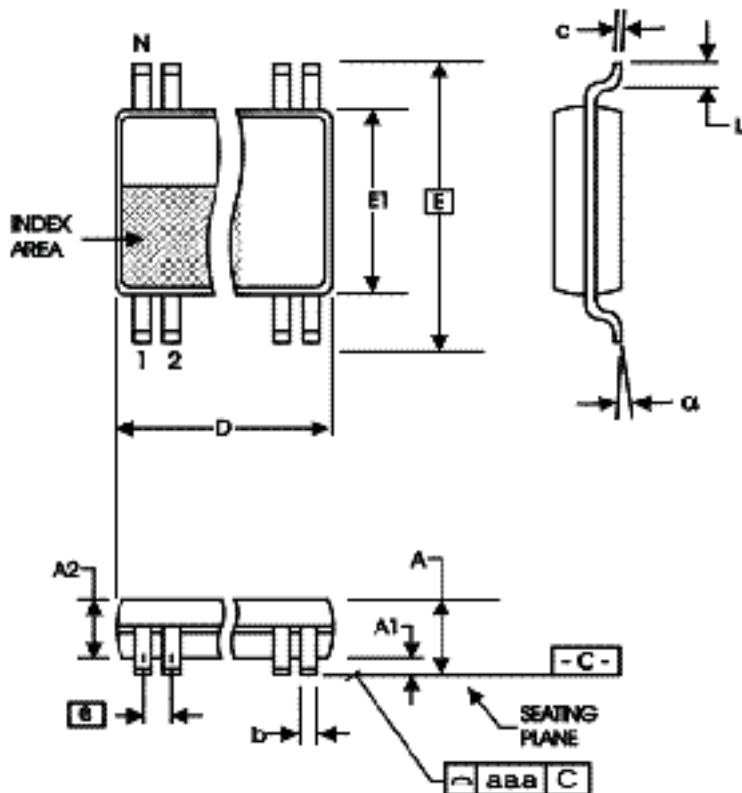

TABLE 9. PACKAGE DIMENSIONS

SYMBOL	Millimeters	
	Minimum	Maximum
N	28	
A	--	1.20
A1	0.05	0.15
A2	0.80	1.05
b	0.19	0.30
c	0.09	0.20
D	9.60	9.80
E	8.10 BASIC	
E1	6.00	6.20
e	0.65 BASIC	
L	0.45	0.75
$\alpha$	0°	8°
aaa	--	0.10

Reference Document: JEDEC Publication 95, MO-153

**TABLE 10. ORDERING INFORMATION**

<b>Part/Order Number</b>	<b>Marking</b>	<b>Package</b>	<b>Shipping Packaging</b>	<b>Temperature</b>
841602AGILF	ICS841602AGILF	28 Lead "Lead-Free" TSSOP	tube	-40°C to 85°C
841602AGILFT	ICS841602AGILF	28 Lead "Lead-Free" TSSOP	tape & reel	-40°C to 85°C

NOTE: Parts that are ordered with an "LF" suffix to the part number are the Pb-Free configuration and are RoHS compliant.

**REVISION HISTORY SHEET**

<b>Rev</b>	<b>Table</b>	<b>Page</b>	<b>Description of Change</b>	<b>Date</b>
A	T10	15	Ordering Information - Removed leaded devices. Updated data sheet format.	4/17/15





## IMPORTANT NOTICE AND DISCLAIMER

RENESAS ELECTRONICS CORPORATION AND ITS SUBSIDIARIES (“RENESAS”) PROVIDES TECHNICAL SPECIFICATIONS AND RELIABILITY DATA (INCLUDING DATASHEETS), DESIGN RESOURCES (INCLUDING REFERENCE DESIGNS), APPLICATION OR OTHER DESIGN ADVICE, WEB TOOLS, SAFETY INFORMATION, AND OTHER RESOURCES “AS IS” AND WITH ALL FAULTS, AND DISCLAIMS ALL WARRANTIES, EXPRESS OR IMPLIED, INCLUDING, WITHOUT LIMITATION, ANY IMPLIED WARRANTIES OF MERCHANTABILITY, FITNESS FOR A PARTICULAR PURPOSE, OR NON-INFRINGEMENT OF THIRD PARTY INTELLECTUAL PROPERTY RIGHTS.

These resources are intended for developers skilled in the art designing with Renesas products. You are solely responsible for (1) selecting the appropriate products for your application, (2) designing, validating, and testing your application, and (3) ensuring your application meets applicable standards, and any other safety, security, or other requirements. These resources are subject to change without notice. Renesas grants you permission to use these resources only for development of an application that uses Renesas products. Other reproduction or use of these resources is strictly prohibited. No license is granted to any other Renesas intellectual property or to any third party intellectual property. Renesas disclaims responsibility for, and you will fully indemnify Renesas and its representatives against, any claims, damages, costs, losses, or liabilities arising out of your use of these resources. Renesas' products are provided only subject to Renesas' Terms and Conditions of Sale or other applicable terms agreed to in writing. No use of any Renesas resources expands or otherwise alters any applicable warranties or warranty disclaimers for these products.

(Disclaimer Rev.1.0 Mar 2020)

### Corporate Headquarters

TOYOSU FORESIA, 3-2-24 Toyosu,  
Koto-ku, Tokyo 135-0061, Japan  
[www.renesas.com](http://www.renesas.com)

### Contact Information

For further information on a product, technology, the most up-to-date version of a document, or your nearest sales office, please visit:  
[www.renesas.com/contact/](http://www.renesas.com/contact/)

### Trademarks

Renesas and the Renesas logo are trademarks of Renesas Electronics Corporation. All trademarks and registered trademarks are the property of their respective owners.