

für Wellenschlauch NW23  
for corrugated pipe NW23

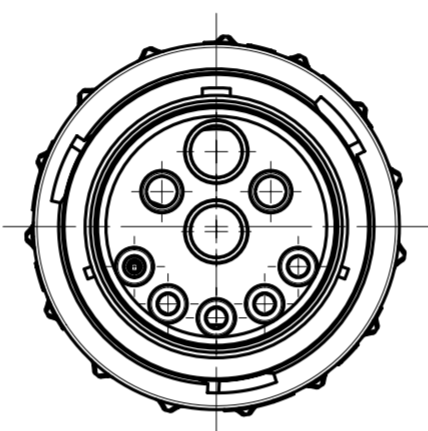

Beutel beinhaltet folgende Einzelteile:  
Packaging includes following single parts:

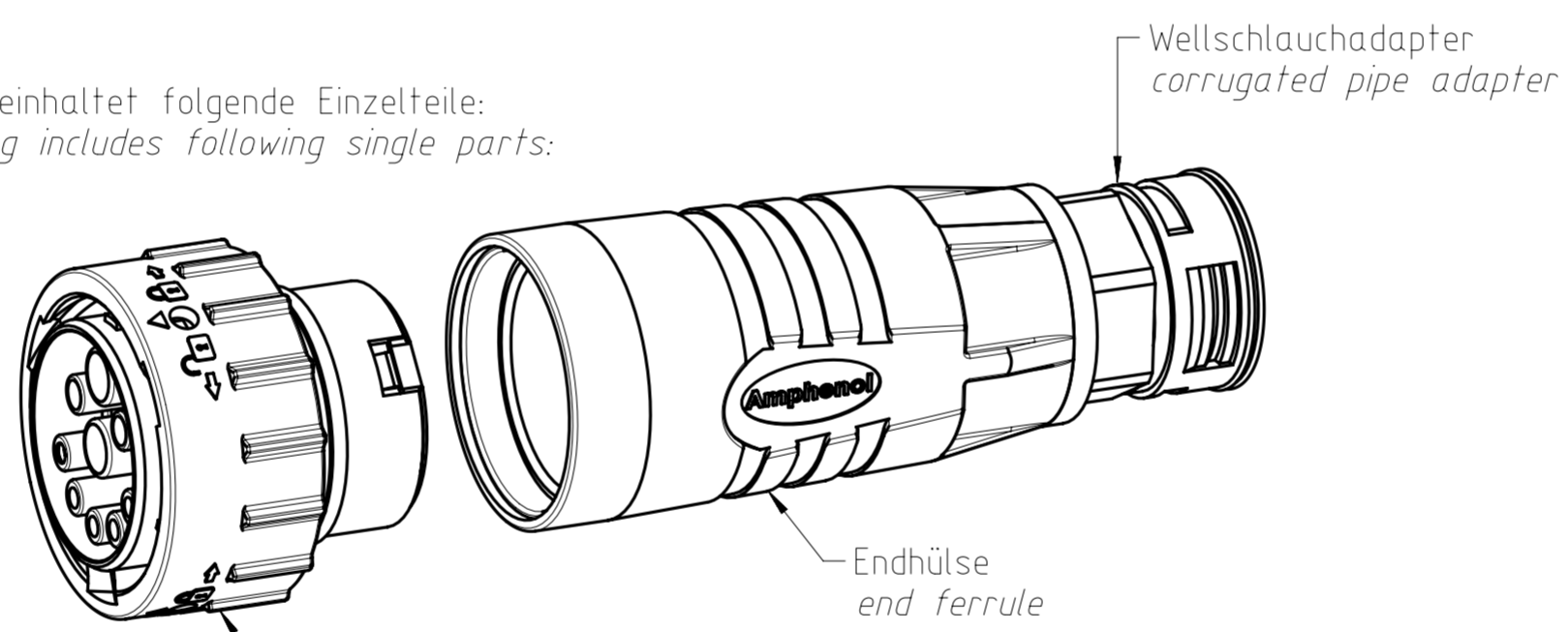

Buchseneinsatz komplett (Kontakt Pin 5 vormontiert)  
female insert assembled (contact pin 5 pre-assembled)

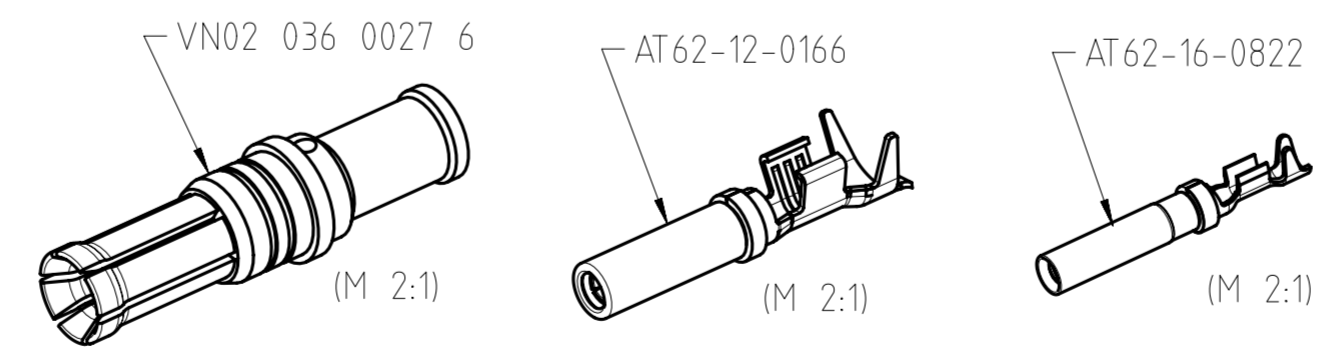

Kontakte in separaten Beutel beigelegt  
contacts attached in separate poly bag:

- Size 8 (2x):  
10mm<sup>2</sup> - VN02 036 0027 6
- Size 12 (2x):  
gestanz / stamped (AWG 12-14): AT62-12-0166 (nickel plated)
- Size 16 (4x):  
gestanz / stamped (0,34-0,5mm<sup>2</sup>): AT62-16-0822 (nickel plated)

Alle technischen Daten wurden unter Laborbedingungen ermittelt und können im Praxisbetrieb abweichen.  
Es handelt sich bei den Angaben weder um Beschaffenheits- noch um Haltbarkeitsgarantien.  
All technical data have been measured in a laboratory environment and can be different during practical usage of the product.  
Any product information is for descriptive usage only and not legally binding particularly the information does not constitute or provide any legal guarantees ("Beschaffenheitsgarantie" or "Haltbarkeitsgarantie")

Weitergabe sowie Vervielfältigung dieser Unterlage, Verwertung und Mitteilung ihres Inhalts nicht gestattet, soweit nicht ausdrücklich zugestanden. Zuwiderhandlungen verpflichten zu Schadenersatz. Alle Rechte für den Fall der Patenterteilung oder Gebrauchsmuster-Eintragung vorbehalten.  
Copying of this document and giving it to others and the use or communication of the contents thereof, are forbidden without express authority. Offenders are liable to the payment of damages. All rights are reserved in the event of the grant of a patent or the registration of the utility model or design.

Polzahl number of contacts	2+2+4+1
Kontakte contacts	2x Size 8 2x Size 12 4x Size 16 1x Size 16 überbrückt / bridged
Bemessungsspannung (DIN EN 60664-1) Rated voltage (DIN EN 60664-1)	24VDC
Strombelastbarkeit bei +40°C (alle Kontakte belastet) Current carrying capacity at 40°C (all contacts under load)	2x60A (10mm <sup>2</sup> ) 2x15A (2,5mm <sup>2</sup> ) 4x5A (0,5mm <sup>2</sup> )
Max. Strombelastbarkeit der Kontakte bei +40°C max. current carrying capacity of contacts at +40°C	2x70A (10mm <sup>2</sup> ) 2x25A (2,5mm <sup>2</sup> )
Verschmutzungsgrad Pollution degree	3
Temperaturbereich Temperature range	-40°C bis +125°C -40°F up to +257°F
Schutzgrad protection class	IP67 / IP69K (gesteckt) IP67 / IP69K (mated)
Mechanische Lebensdauer Mechanical operations	≥100 Steckzyklen ≥100 mating cycles
Werkstoff Dichtungen material gaskets	NBR, Silikon NBR, silicone
Werkstoff Gehäuse material housing	Polyamid schwarz, UL94V-0 polyamide black, UL94V-0
Werkstoff Kontaktträger material housing	Polyamid schwarz, UL94V-0 polyamide black, UL94V-0
Werkstoff Wellrohradapter material corrugated pipe adapter	Polyamid schwarz, UL94V-0 polyamide black, UL94V-0
Werkstoff Kontakte + Oberfläche material contacts + surface	Kupferlegierung, vernickelt copper alloy, nickel plated
Verriegelung locking	Bajonett Bayonet

Stecker nach ISO 11783-2  
connector acc. to ISO 11783-2

Version frei konfektionierbar mit Wellenschlauchadapter  
(Wellenschlauch wird nicht mitgeliefert)  
version free assembly with corrugated pipe adapter  
(corrugated pipe not included)

Crimpausrüstung siehe Montageanleitung  
- N 22 000 0029 (10mm<sup>2</sup>)  
equipment for crimping according to assembly instruction  
- N 22 000 0029 (10mm<sup>2</sup>)

Gewicht (errechnet) / Calc. WT.: 134,73 g	Zul. Abw./Tolerances	Maßstab / Scale: 1:1	A2	☐
Prüfmaß / Testdimension	ISO 2768-c	CUSTOMER DRAWING		
Teilindex / Partindexnumber:	DIN / ISO 13715	Kabeldose female cable connector		
Bagatelle change:	Gez. 11.01.2017 Drawn: RSCHAEDEL Status: Released Gepr. 18.07.2019 Checked: MGRIMM	Blatt / Sheet 1 1 Bl.		
02 201900126 12.07.2019 SWAHL	Amphenol Tuchel Industrial GmbH	M	AHDP06-24-91S-BS3-K10S	1
01 201700501 27.02.2018 RSCHA				
Index / Änderung / Description	Datum / Date	Name	Ers. f. / Replacement for:	

# AT Series™ - Contact Size 16 Options

Machined Contacts, Sockets & Pins				
Part Number	Description	Size	AWG	Type
AT60-215-1631	Male Contact - Pin, Gold-plated	16	14	Machined
AT62-209-1631	Female Contact - Socket, Gold-plated	16	14	Machined
AT60-215-16141	Male Contact - Pin, Nickel-plated	16	14	Machined
AT62-209-16141	Female Contact - Socket, Nickel-plated	16	14	Machined
AT60-202-1631	Male Contact - Pin, Gold-plated	16	16-20	Machined
AT62-201-1631	Female Contact - Socket, Gold-plated	16	16-20	Machined
AT60-202-16141	Male Contact - Pin, Nickel-plated	16	16-20	Machined
AT62-201-16141	Female Contact - Socket, Nickel-plated	16	16-20	Machined
AT60-202-1631-22	Male Contact - Pin, Gold-plated	16	22-24	Machined
AT62-201-1631-22	Female Contact - Socket, Gold-plated	16	22-24	Machined
AT60-202-16141-22	Male Contact - Pin, Nickel-plated	16	22-24	Machined
AT62-201-16141-22	Female Contact - Socket, Nickel-plated	16	22-24	Machined

Tooling - Machined Contacts		
Part	Part Number	Description
	CA-5D12	Universal Hand Crimp Tool, Size 12/16/20 (Machined contacts only)
	CA-5E12	Pneumatic Crimp Tool, Size 12/16/20 (Machined contacts only)

Contact Removal Tools		
Part	Part Number	Description
	ATRT-100	Used for removal of contacts for A Series™ products
	AT11-310-1605	Contact Removal Tool, Plastic, Size 16
	A114017	Sealing Plug, Size 16, White

Stamped & Formed Contacts, Sockets & Pins				
Part Number	Description	Size	AWG	Type
AT60-14-0144	Male Contact - Pin, Gold-plated	16	14-16	Stamped & Formed
AT62-14-0144	Female Contact - Socket, Gold-plated	16	14-16	Stamped & Formed
AT60-14-0122	Male Contact - Pin, Nickel-plated	16	14-16	Stamped & Formed
AT62-14-0122	Female Contact - Socket, Nickel-plated	16	14-16	Stamped & Formed
AT60-16-0144	Male Contact - Pin, Gold-plated	16	16-18	Stamped & Formed
AT62-16-0144	Female Contact - Socket, Gold-plated	16	16-18	Stamped & Formed
AT60-16-0122	Male Contact - Pin, Nickel-plated	16	16-18	Stamped & Formed
AT62-16-0122	Female Contact - Socket, Nickel-plated	16	16-18	Stamped & Formed
AT60-16-0644	Male Contact - Pin, Gold-plated	16	18-20	Stamped & Formed
AT62-16-0644	Female Contact - Socket, Gold-plated	16	18-20	Stamped & Formed
AT60-16-0622	Male Contact - Pin, Nickel-plated	16	18-20	Stamped & Formed
AT62-16-0622	Female Contact - Socket, Nickel-plated	16	18-20	Stamped & Formed
AT60-16-0844	Male Contact - Pin, Gold-plated	16	20-22	Stamped & Formed
AT62-16-0844	Female Contact - Socket, Gold-plated	16	20-22	Stamped & Formed
AT60-16-0822	Male Contact - Pin, Nickel-plated	16	20-22	Stamped & Formed
AT62-16-0822	Female Contact - Socket, Nickel-plated	16	20-22	Stamped & Formed



Tooling - Stamped & Formed Contacts		
Part	Part Number	Description
	MFX-3950	Crimp Die - Size 16, 18-20AWG (S&F contacts only)
	MFX-3953	Crimp Die - Size 16, 16-18AWG (S&F contacts only)
	MFX-3975	Crimp Die - Size 16, 14-16AWG (S&F contacts only)
	MFX-3990	Crimp Die - Size 16, 20-22AWG (S&F contacts only)
	ATT-16-00	Hand Crimp Tool - Size 16, 14-16AWG (S&F contacts only)
	ATT-16-01	Hand Crimp Tool - Size 16, 18-20AWG (S&F contacts only)
	ATT-1612-03	Hand Crimp Tool - Size 16, 20-22AWG (S&F contacts only)

**Amphenol Sine Systems**  
 44724 Morley Drive  
 Clinton Township, MI 48036 USA  
[www.amphenol-sine.com](http://www.amphenol-sine.com)  
 09/2021

# MagnaMate™ ATHP - DuraMate™ AHDP - DuraMate™ AHDM Series - Contact Size 12 Options



Machined Contacts, Sockets & Pins				
Part Number	Description	Size	AWG	Type
AT60-204-12141-10	Male Contact - Pin, Nickel-plated	12	10-12	Machined
AT62-203-12141-10	Female Contact - Socket, Nickel-plated	12	10-12	Machined
AT60-220-1231	Male Contact - Pin, Gold-plated	12	12-14	Machined
AT62-210-1231	Female Contact - Socket, Gold-plated	12	12-14	Machined
AT60-204-12141	Male Contact - Pin, Nickel-plated	12	12-14	Machined
AT62-203-12141	Female Contact - Socket, Nickel-plated	12	12-14	Machined

DiagnosticGrade™ Machined Contacts, Sockets & Pins				
• Smaller AWG for Diagnostic Applications • Gold-plated • Increased Mating Cycles • Cost-effective				
Part Number	Description	Size	AWG	Type
65-54749	Male Contact - DiagnosticGrade™, Pin, Gold-plated	12	20	Machined
AT62-210-1231-1820	Female Contact - DiagnosticGrade™, Socket, Gold-plated	12	20	Machined

Tooling - Machined Contacts		
Part	Part Number	Description
	CA-5D12	Universal Hand Crimp Tool, Size 12/16/20 (Machined contacts only)
	CA-5E12	Pneumatic Crimp Tool, Size 12/16/20 (Machined contacts only)

Contact Removal Tools		
Part	Part Number	Description
	AT11-337-1205	Contact Removal Tool, Plastic, Size 12
	A114017	Sealing Plug, Size 12, White

Stamped & Formed Contacts, Sockets & Pins				
Part Number	Description	Size	AWG	Type
AT60-12-0244	Male Contact - Pin, Gold-plated	12	10-12	Stamped & Formed
AT62-12-0244	Female Contact - Socket, Gold-plated	12	10-12	Stamped & Formed
AT60-12-0222	Male Contact - Pin, Nickel-plated	12	10-12	Stamped & Formed
AT62-12-0222	Female Contact - Socket, Nickel-plated	12	10-12	Stamped & Formed
AT60-12-0144	Male Contact - Pin, Gold-plated	12	12-14	Stamped & Formed
AT62-12-0144	Female Contact - Socket, Gold-plated	12	12-14	Stamped & Formed
AT60-12-0166	Male Contact - Pin, Nickel-plated	12	12-14	Stamped & Formed
AT62-12-0166	Female Contact - Socket, Nickel-plated	12	12-14	Stamped & Formed

Tooling - Stamped & Formed Contacts		
Part	Part Number	Description
	MXF-3973	Crimp Die - Size 12 (S&F contacts only)
	MXF-3985	Crimp Die - Size 12 (S&F contacts only) 10-12AWG -02XX Series
	ATT-12-00	Hand Crimp Tool - Size 12, 12AWG (S&F contacts only)
	ATT-12-01	Hand Crimp Tool - Size 12, 10AWG (S&F contacts only)

**Amphenol Sine Systems**  
 44724 Morley Drive  
 Clinton Township, MI 48036 USA  
[www.amphenol-sine.com](http://www.amphenol-sine.com)  
 01/2022

Copying of this document and giving it to others and the use or communication of the contents thereof, are forbidden without express authority. Offenders are liable to the payment of damages. All rights are reserved in the event of the grant of a patent or the registration of the utility model or design.

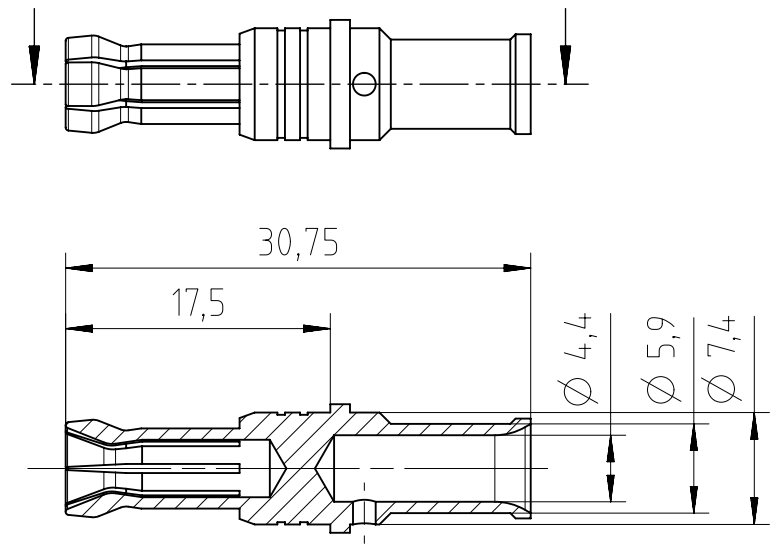

Material: Kupferlegierung  
*material: copper alloy*  
 Oberfläche: vernickelt  
*surface coating: nickel plated*  
 Für Kontaktstift  $\varnothing$  3,6mm  
*for male contact  $\varnothing$  3,6mm*

Anschlussquerschnitt: 10mm<sup>2</sup>  
*cross section: 10mm<sup>2</sup>*

100 Stück in einem Beutel verpackt  
*100 pcs packed in one poly bag*

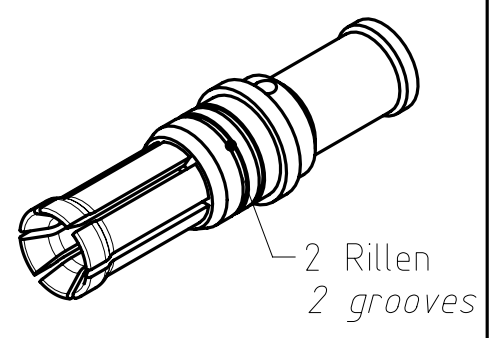

Alle technischen Daten wurden unter Laborbedingungen ermittelt und können im Praxisbetrieb abweichen.  
 Es handelt sich bei den Angaben weder um Beschaffenheits- noch um Haltbarkeitsgarantien.  
*All technical data have been measured in a laboratory environment and can be different during practical usage of the product. Any product information is for descriptive usage only and not legally binding; particularly the information does not constitute or provide any legal guarantees ("Beschaffenheitsgarantie" or "Haltbarkeitsgarantie").*

Weitergabe sowie Vervielfältigung dieser Unterlage, Verwertung und Mitteilung ihres Inhalts nicht gestattet, soweit nicht ausdrücklich zugestanden. Zuwiderhandlungen verpflichten zu Schadensersatz. Alle Rechte für den Fall der Patenterteilung oder Gebrauchsmuster-Eintragung vorbehalten.

Gewicht (errechnet) / Calc WT :		Zul. Abw./Tolerances :		Maßstab / Scale : 2:1		A4			
Prüfmaß / Testdimension		ISO 2768-mH				CUSTOMER DRAWING			
Teileindex / Partindexnumber:									
Bagatelle change:						Buchsenkontakt <i>female contact</i>			
				Gez.	30.03.2017	M   VN 02 036 0027 6			
				Drawn	AZN_NPFEIFFE				
				Status	Released				
				Gepr.	01.04.2019				
				Checked	MGRIMM				
04	201900099	01.04.2019	MTOLK	<b>Amphenol Tuchel Industrial GmbH</b>		Ers. f. / Replacement for :			
03	201800125	01.03.2018	NPFEI						
02	201800066	25.01.2018	NPFEI						
01	201500766	31.03.2017	NPFEI						
Index	Anderung / Description	Datum / Date	Name						