

G3TB

I/O Solid State Relay



I/O SSR Used as Interface between Logic Circuitry and Load

- A variety of AC/DC input and output modules are classified by color.
- Operation can be monitored easily by LED indicator.
- Dielectric strength of 4,000 V between input and output terminals.
- Lineup includes models with UL and CSA certification (model numbers ending in "-US").

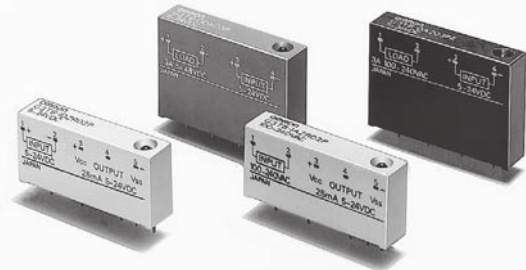

Refer to "Solid State Relays Common Precautions".

RoHS Compliant

List of Models

Input Modules

Isolation	Indicator	Logic level Supply voltage	Logic level Supply current	Rated input voltage	Model	Minimum packing unit
Photocoupler	Yes	4 to 32 VDC	25 mA	100 to 240 VAC	G3TB-IAZR02P	20 pcs
				5 to 24 VDC	G3TB-IDZR02P	

Output Modules

Isolation	Zero cross function	Indicator	Rated output voltage	Rated input voltage	Model	Minimum packing unit	
Photocoupler	Yes	Yes	3 A at 100 to 240 VAC	5 to 24 VDC	G3TB-OA203PZ	20 pcs	
		No		4 to 24 VDC	G3TB-OA203PZM		
		Yes		5 to 24 VDC	G3TB-OA203PL		
		No		4 to 24 VDC	G3TB-OA203PLM		
	No	Yes	3 A at 5 to 48 VDC	5 to 24 VDC	G3TB-ODX03P		
		No		4 to 24 VDC	G3TB-ODX03PM		
		Yes		5 to 24 VDC	G3TB-OD201P		
		No		4 to 24 VDC	G3TB-OD201PM		
	-	-	-	1.5 A at 48 to 200 VDC	5 to 24 VDC		G3TB-OD201P
					4 to 24 VDC		G3TB-OD201PM

Ratings

Input Module

Input

Model	Item	Rated voltage	Operating voltage	Input current	Voltage level	
					Must operate voltage	Must release voltage
G3TB-IAZR02P		100 to 240 VAC	80 to 264 VAC	5 mA max.	80 VAC max.	10 VAC min.
G3TB-IDZR02P		5 to 24 VDC	4 to 32 VDC	5 mA max.	4 VDC max.	1 VDC min.

Output Module

Input

Model	Item	Rated voltage	Operating voltage	Input current	Voltage level	
					Must operate voltage	Must release voltage
G3TB-OA203PZ		5 to 24 VDC	4 to 32 VDC	5 mA max.	4 VDC max.	1 VDC min.
G3TB-OA203PZM		4 to 24 VDC	3 to 32 VDC		3 VDC max.	
G3TB-OA203PL		5 to 24 VDC	4 to 32 VDC		4 VDC max.	
G3TB-OA203PLM		4 to 24 VDC	3 to 32 VDC		3 VDC max.	
G3TB-ODX03P		5 to 24 VDC	4 to 32 VDC		4 VDC max.	
G3TB-ODX03PM		4 to 24 VDC	3 to 32 VDC		3 VDC max.	
G3TB-OD201P		5 to 24 VDC	4 to 32 VDC		4 VDC max.	
G3TB-OD201PM		4 to 24 VDC	3 to 32 VDC		3 VDC max.	

Output

Model	Item	Applicable load			
		Rated load voltage	Load voltage range	Load current	Inrush current
G3TB-OA203PZ		100 to 240 VAC	75 to 264 VAC	0.05 to 3 A *1, 2	45 A (60 Hz, 1 cycle)
G3TB-OA203PZM					
G3TB-OA203PL					
G3TB-OA203PLM					
G3TB-ODX03P		5 to 48 VDC	4 to 60 VDC	0.01 to 3 A *1, 2	18 A (10 ms)
G3TB-ODX03PM		48 to 200 VDC	40 to 200 VDC	0.01 to 1.5 A *1, 2	9 A (10 ms)
G3TB-OD201P					
G3TB-OD201PM					

Output

Model	Item	Logic level supply voltage	Output breakdown voltage	Output current
G3TB-IAZR02P		4 to 32 VDC	32 VDC max.	25 mA max.
G3TB-IDZR02P		4 to 32 VDC		

*1. The minimum current value is measured at 10°C min.
 *2. The applicable output load current varies depending on the ambient temperature. Refer to reference data the "Load Current vs. Ambient Temperature" rating characteristic for details.

G3TB

Characteristics

Input Module

Item	Model	G3TB-IAZR02P	G3TB-IDZR02P
Operate time		20 ms max.	1 ms max.
Release time		20 ms max.	1 ms max.
Output ON voltage drop		0.4 V max.	
Leakage current		100 μ A max.	
Insulation resistance		100 M Ω min. (at 500 VDC)	
Dielectric strength		4,000 VAC, 50/60 Hz for 1 min between input and output	
Vibration resistance		10 to 55 to 10 Hz, 0.75-mm single amplitude (1.5mm double amplitude)	
Shock resistance		1,000 m/s ²	
Storage temperature		-30°C to 100°C (with no icing or condensation)	
Ambient operating temperature		-30°C to 80°C (with no icing or condensation)	
Ambient operating humidity		45% to 85%RH	
Weight		Approx. 22 g	

Output Module

Item	Model	G3TB-OA203PZ	G3TB-OA203PZM	G3TB-OA203PL	G3TB-OA203PLM	G3TB-ODX03P	G3TB-ODX03PM	G3TB-OD201P	G3TB-OD201PM
Operate time		1/2 of load power source cycle + 1 ms max.		1 ms max.		0.5 ms max.			
Release time		1/2 of load power source cycle + 1 ms max.				2 ms max.			
Output ON voltage drop		1.6 V (RMS) max.				1.6 V max.		2.5 V max.	
Leakage current		5 mA max. (at 200 VAC)				1 mA max.			
Insulation resistance		100 M Ω min. (at 500 VDC)							
Dielectric strength		4,000 VAC, 50/60 Hz for 1 min between input and output							
Vibration resistance		10 to 55 to 10 Hz, 0.75-mm single amplitude (1.5mm double amplitude)							
Shock resistance		1,000 m/s ²							
Storage temperature		-30°C to 100°C (with no icing or condensation)							
Ambient operating temperature		-30°C to 80°C (with no icing or condensation) Minimum load current: 10 to 80°C Refer to the <i>Load Current - Ambient Temperature Rating</i> for the minimum load current.							
Ambient operating humidity		45% to 85%RH							
Weight		Approx. 32 g							

Engineering Data

Load Current vs. Ambient Temperature Characteristics

G3TB-OA203PZ G3TB-OA203PLM
G3TB-OA203PZM G3TB-OA203PL

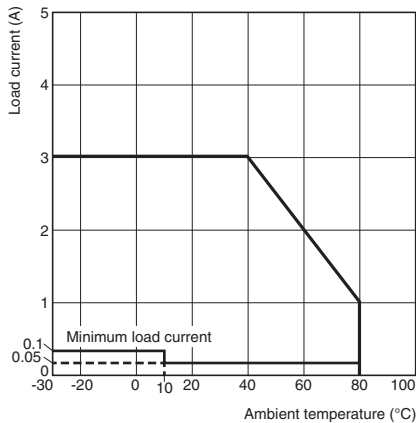

G3TB-ODX03P G3TB-ODX03PM

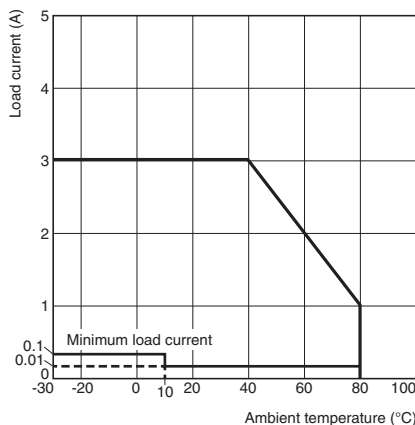

G3TB-OD201P G3TB-OD201PM

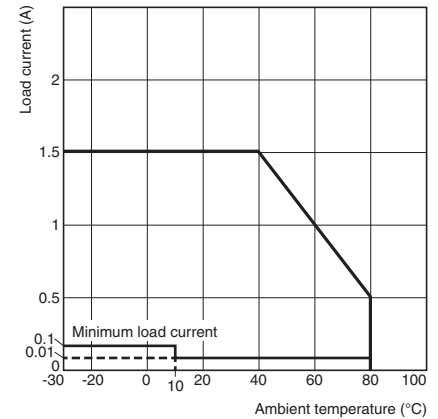

One Cycle Surge Current: Non-repetitive Non-repetitive (Keep the inrush current to half the rated value if it occurs repetitively.)

G3TB-OA203PZ G3TB-OA203PL
G3TB-OA203PZM G3TB-OA203PLM

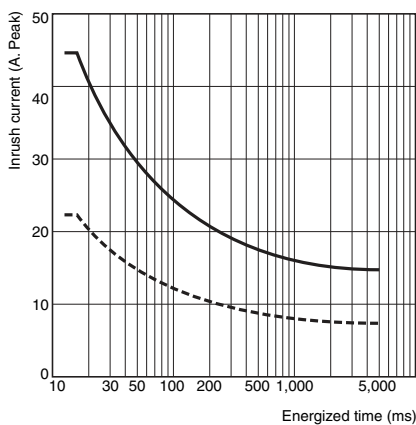

G3TB-ODX03P G3TB-ODX03PM

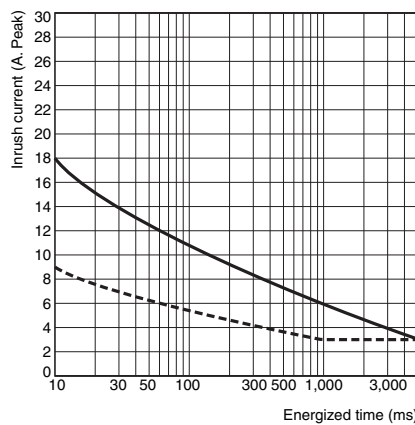

G3TB-OD201P G3TB-OD201PM

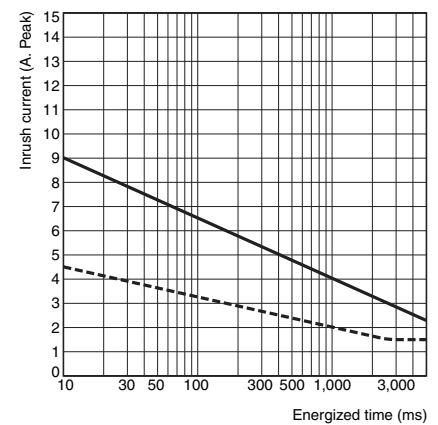

■ Circuit Configuration

Type	Model	Case color	Indicator	Circuit
AC input	G3TB-IAZR02P	Yellow	Yes	
DC input	G3TB-IDZR02P	White	Yes	
AC output	G3TB-OA203PZ G3TB-OA203PL	Black	Yes	
	G3TB-OA203PZM G3TB-OA203PLM		No	
DC output	G3TB-ODX03P G3TB-OD201P	Red	Yes	
	G3TB-ODX03PM G3TB-OD201PM		No	

• Example of Logic Output Circuit

Example 1. G3TB-I

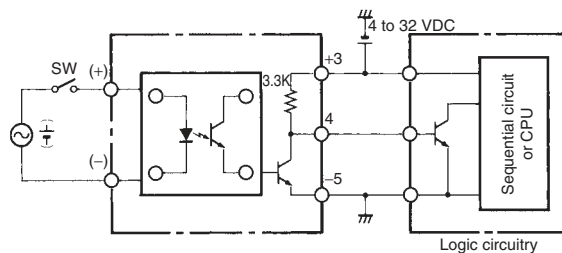

Note: AC- and DC-input versions are available.

Example 2. G3TB-I

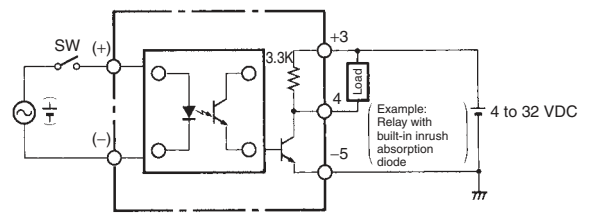

Note: AC- and DC-input versions are available.

■ Dimensions

(Unit: mm)

Input SSR G3TB-I

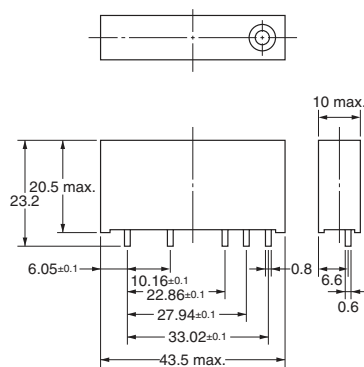
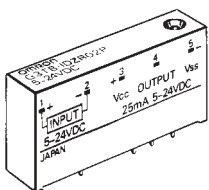

PCB Dimensions (Bottom View)

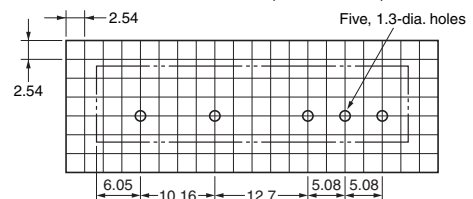

Terminal Arrangement (Bottom View)

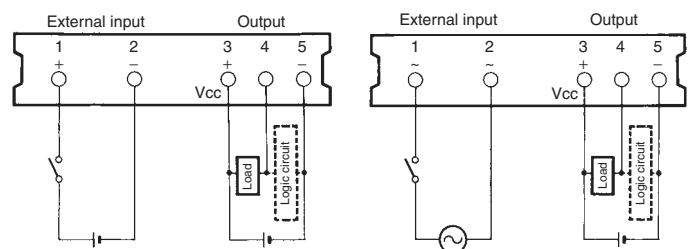

Output SSR G3TB-I

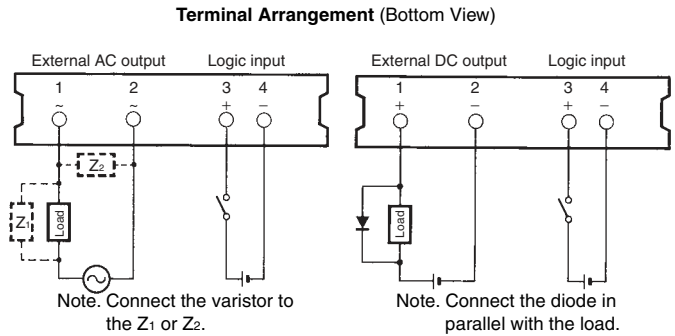
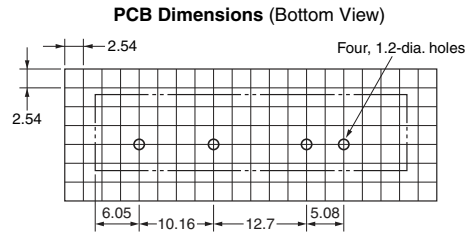
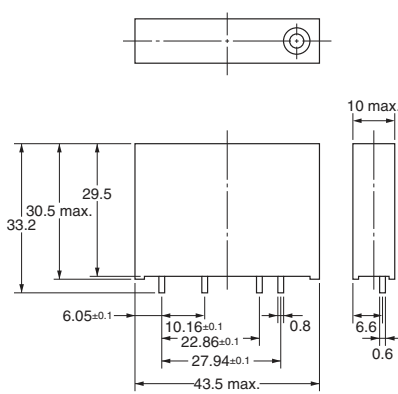
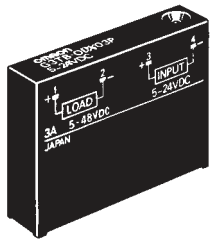

■ Safety Precautions

● Please refer to “Solid State Relays Common Precautions” for correct use.

Precautions for Correct Use

• SSR for I/O classification by the color is as follows:

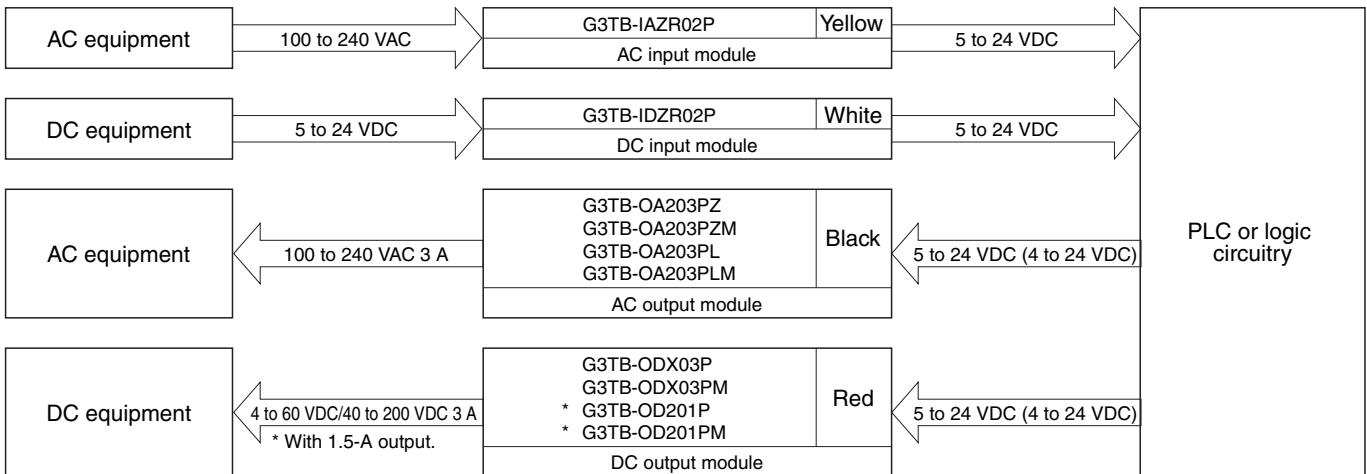

• When mounting more than one output module, make a distance of 5 mm minimum between adjacent SSRs. Up to 16-point, 3-A load switching is possible.

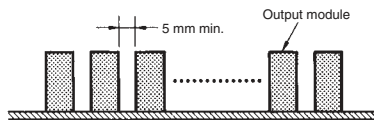

- Application examples provided in this document are for reference only. In actual applications, confirm equipment functions and safety before using the product.
- Consult your OMRON representative before using the product under conditions which are not described in the manual or applying the product to nuclear control systems, railroad systems, aviation systems, vehicles, combustion systems, medical equipment, amusement machines, safety equipment, and other systems or equipment that may have a serious influence on lives and property if used improperly. Make sure that the ratings and performance characteristics of the product provide a margin of safety for the system or equipment, and be sure to provide the system or equipment with double safety mechanisms.

Note: Do not use this document to operate the Unit.