

AUDIO LINE AMPLIFIER with MUTE FUNCTION

■ GENERAL DESCRIPTION

The **NJM2174** is a low voltage audio line amplifier designed for audio items.

Internal closed loop voltage gain is suitable for amplifier of small line signal in digital audio items. It includes mute circuit which realizes very low turn-noise at power on/off.

It is suitable for digital audio items with line out.

■ PACKAGE OUTLINE

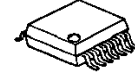

NJM2174V

■ FEATURES

- Operating Voltage 4.5 to 5.5V
- Operating Current 2.5mA typ. at $V^+=5V$
- Maximum Output Voltage 4dBV typ. at THD=0.1%
- Closed Loop Voltage Gain 3.5dB typ. at $f=1kHz$
2.5dB typ. at $f=100kHz$
- Mute Function -85dB typ.
- Supply Voltage Rejection Ratio 60dB typ.
- Bipolar Technology
- Package Outline SSOP14

■ PIN CONFIGURATION

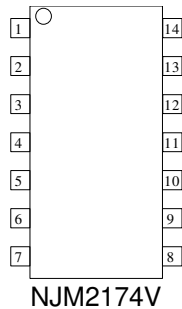

PIN FUNCTION

- | | |
|-----------|-----------|
| 1. GND | 8. BIAS |
| 2. NC | 9. NC |
| 3. OUT-R | 10. NC |
| 4. MUTE 1 | 11. IN-L |
| 5. MUTE 2 | 12. OUT-L |
| 6. MUTE C | 13. NC |
| 7. IN-R | 14. V^+ |

■ BLOCK DIAGRAM

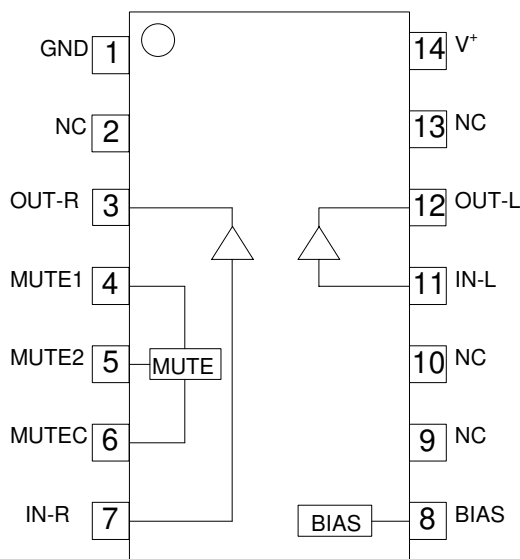

■ ABSOLUTE MAXIMUM RATINGS (Ta=25°C)

PARAMETER	SYMBOL	RATINGS	UNIT
Supply Voltage	V ⁺	7	V
Power Dissipation	P _D	300	mW
Operating Temperature Range	T _{opr}	-20 to +75	°C
Storage Temperature Range	T _{stg}	-40 to +125	°C

■ ELECTRICAL CHARACTERISTICS (V⁺=5V, V_{IN}=-3dBV, R_L=47kΩ, f=1kHz, Ta=25°C)

PARAMETER	SYMBOL	TEST CONDITION	MIN.	TYP.	MAX.	UNIT
Operating Voltage Range	V ⁺		4.5	5.0	5.5	V
Operating Current	I _{CC}	No signal	-	2.5	4.5	mA
Reference Voltage	V _{REF}	No signal	2.0	2.3	2.6	V
Closed Loop Voltage Gain1	G _{V1}		2.5	3.5	4.5	dB
Closed Loop Voltage Gain2	G _{V2}	f=100kHz	-7.0	-2.5	-2.0	dB
Channel Gain Balance	ΔG _V		-0.5	0	0.5	dB
Maximum Output Voltage	V _{OM}	THD=0.1%	3	4	-	dBV
Total Harmonic Distortion	THD		-	0.005	0.01	%
Output Noise Voltage	V _{NO}	Rg=0Ω, A-Weighted	-	-95	-88	dBV
Mute Level	MUTE	V _O /V _{IN}	-	-85	-70	dB
Channel Separation	CS		70	90	-	dB
Supply Voltage Rejection Ratio	SVR	V _{RP} =-20dBV, Rg=0Ω	45	60	-	dB
High Level Input Voltage	V _{IH}		2.0	-	V ⁺	V
Low Level Input Voltage	V _{IL}		0	-	0.3	V

■ CONTROL TERMINAL

MUTE1(4pin)	MUTE2(5pin)	STATUS
L	L	IC doesn't output the signal.
L	H	IC doesn't output the signal.
H	L	IC set up 3.5dB typ. voltage gain.
H	H	IC doesn't output the signal.

■ APPLICATION CIRCUIT

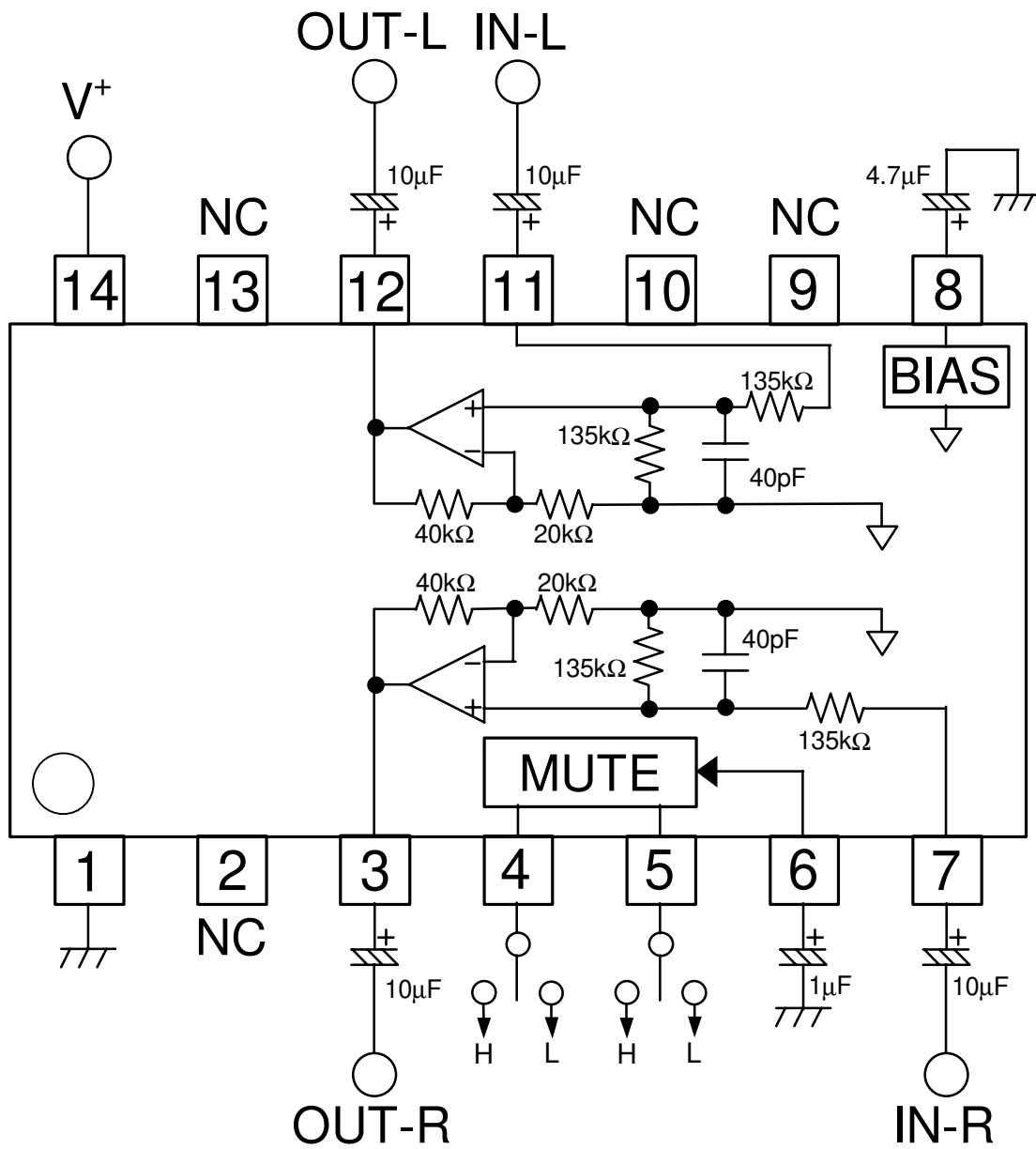

■ TERMINAL DESCRIPTION

No.	SYMBOL	FUNCTION	EQUIVALENT CIRCUIT	VOLTAGE
1	GND	Ground Terminal		0V
2	NC			
3 12	OUT-R OUT-L	Rch Output Lch Output		2.3V
4 5	MUTE1 MUTE2	Mute Switch Terminal 1 Mute Switch Terminal 2		-
6	MUTE _C	Pop Noise reduction for Mute Switch		-
7 11	IN-R IN-L	Rch Input Lch Input		$V_{+}/2$

■TERMINAL DESCRIPTION

No.	SYMBOL	FUNCTION	EQUIVALENT CIRCUIT	VOLTAGE
8	BIAS	Reference Voltage		2.3V
9	NC			
10	NC			
13	NC			
14	V ⁺	Power Supply Terminal		V ⁺