

SIGN	DATE	DESCRIPTION	APPROVER

THIS IS CAD DRAWING, DO NOT REVISE MANUALLY!!!

Material

- Terminal body
(metal housing): Brass(CuZn)
- Terminal screw: Steel Zinc plating "-" slot type
- Contact pin: Brass
- Surface of solder tail: Tin plated
- Insulator (housing): Thermoplastic (UL94V-0)

Electrical

- Voltage rating: 150VAC
- Current rating: 10A
- Wire range:
Solid wire(AWG): 16-24
Stranded wire(AWG): 16-24
- Torque: 1.7Lb-In
- Screw: M2
- Wire strip length: 5-6mm
- Withstanding Voltage: 1.3KV
- Operating temperature: -30°C to +105°C
- Soldering temperature: 250°C±10°C/5 Sec

RoHS Compliant

PART NUMBER:

OSTYA152150

COLOR

- 0: Black
- 5: Green (Standard)
- 6: Blue
- 8: Grey

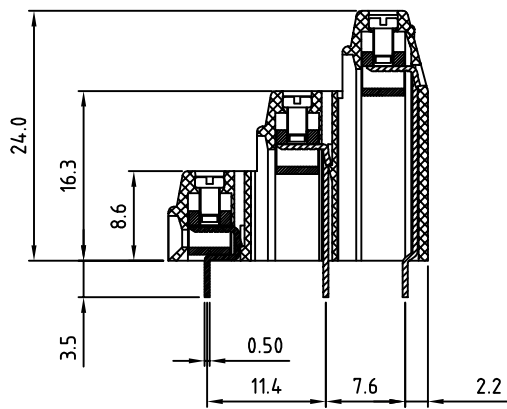
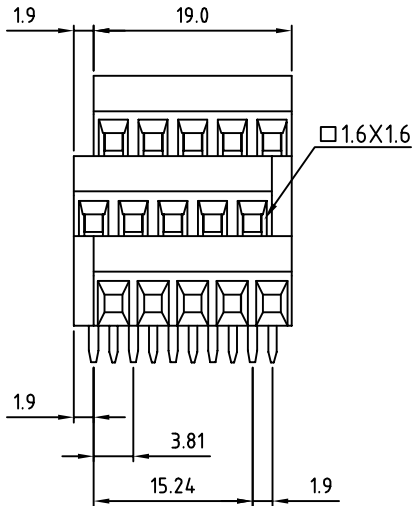
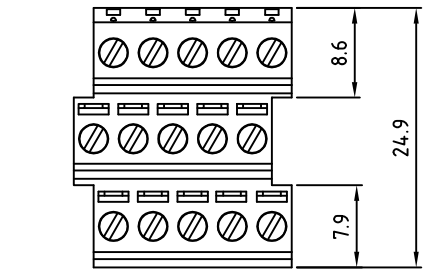

P.C.B LAYOUT

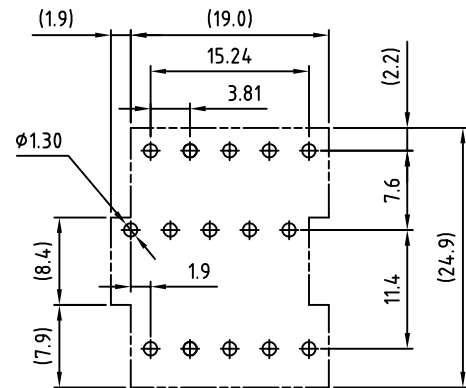

THESE DRAWINGS AND SPECIFICATIONS ARE THE PROPERTY OF ON-SHORE TECHNOLOGY, INC. AND SHALL NOT BE REPRODUCED, COPIED OR USED IN ANY MANNER WITHOUT THE PRIOR WRITTEN CONSENT OF ON-SHORE TECHNOLOGY, INC.



TITLE		OSTYA 3.81 Series solid block 15p (5p×3)				
PART NO.	OSTYA152150	DWG NO.	OSTYA152150.DWG			
APPROVED	CHECKED	DESIGNED	DRAWN	CUST NO.	Tolerance	
Shi Jun 2006.10.20	Marvin 2006.10.20	Marvin 2006.10.20	Marvin 2006.10.20		UNIT: mm	X. ±0.50
					SCALE: NONE	X.X ±0.30
					SHEET: 01/01	X.XX ±0.10
					REV.: C	X° ±1°