



# PRODUCT SPECIFICATION

## INVERTED RIGHT ANGLE MODULAR JACKS

### 1.0 SCOPE

This Product Specification covers the 1.02 mm (.040 inch) centerline (pitch) printed circuit board (PCB) modular jack connector series with selective gold and tin plating.

### 2.0 PRODUCT DESCRIPTION

#### 2.1 PRODUCT NAME AND SERIES NUMBER(S)

Single Port Inverted Modular Jack	43860
Single Port Inverted Mini-PCI Modular Jack	44380
Dual Port Inverted Modular Jack	43814
Ganged Inverted Modular Jack	44248
Single Port Inverted Modular Jack with Keep-out Feature	44620

#### 2.2 DIMENSIONS, MATERIALS, PLATINGS AND MARKINGS

See the appropriate sales drawings (SD-43860-001, SD-44380-001, SD-43814-001, SD-44248-001) for information on dimensions, materials, plating and markings.

#### 2.3 SAFETY AGENCY APPROVALS

UL File Number..... E107635  
CSA File Number..... LR19980

### 3.0 APPLICABLE DOCUMENTS AND SPECIFICATIONS

FCC Rules and Regulations, Part 68, Subpart F  
REA Bulletin 345-81, PE-76; Specification for modular telephone set hardware  
ANSI/EIA/TIA-568  
IEC-60603-7  
UL 1863  
MIL-STD-202; General requirements for test specifications

### 4.0 RATINGS

#### 4.1 VOLTAGE

56.5 V DC  
150 V<sub>RMS</sub> AC (Ringing voltage only)

#### 4.2 CURRENT

1.5 Amps @ 25°C

#### 4.3 TEMPERATURE

Operating: - 40°C to + 85°C  
Nonoperating:\* - 40°C to + 85°C  
\*Packaging materials should not exceed + 50°C

<u>REVISION:</u> <b>H3</b>	<u>ECR/ECN INFORMATION:</u> EC No: <b>UCP2012-3129</b> DATE: <b>2012/03/22</b>	<u>TITLE:</u> <b>PRODUCT SPECIFICATION INVERTED RIGHT ANGLE MODULAR JACKS</b>	<u>SHEET No.</u> <b>1 of 5</b>
<u>DOCUMENT NUMBER:</u> <b>PS-43860-003</b>	<u>CREATED / REVISED BY:</u> <b>NNGUYEN</b>	<u>CHECKED BY:</u> <b>JBELL</b>	<u>APPROVED BY:</u> <b>FSMITH</b>



# PRODUCT SPECIFICATION

## 5.0 PERFORMANCE

### 5.1 ELECTRICAL REQUIREMENTS

	DESCRIPTION	TEST CONDITION	REQUIREMENT
	<b>Contact Resistance (Low Level)</b>	Mate connectors: apply a maximum voltage of <b>20 mV</b> and a current of <b>100 mA</b> . (Measurement locations in Section 7.0)	<b>20 milliohms</b> MAXIMUM [initial]
	<b>Insulation Resistance</b>	Unmated connector, mounted to a PCB: apply a voltage of <b>100 VDC</b> between adjacent terminals and between terminals to ground.	<b>500 Megohms</b> MINIMUM
	<b>Dielectric Withstanding Voltage</b>	Mate connectors: apply a voltage of <b>1000 VAC</b> for <b>1 minute</b> between adjacent terminals and <b>1500 VAC</b> between terminals to shield.	No breakdown; current leakage < <b>5 mA</b>

<u>REVISION:</u> <b>H3</b>	<u>ECR/ECN INFORMATION:</u> EC No: <b>UCP2012-3129</b> DATE: <b>2012/03/22</b>	<u>TITLE:</u> <b>PRODUCT SPECIFICATION INVERTED RIGHT ANGLE MODULAR JACKS</b>	<u>SHEET No.</u> <b>2 of 5</b>
<u>DOCUMENT NUMBER:</u> <b>PS-43860-003</b>	<u>CREATED / REVISED BY:</u> <b>NNGUYEN</b>	<u>CHECKED BY:</u> <b>JBELL</b>	<u>APPROVED BY:</u> <b>FSMITH</b>



# PRODUCT SPECIFICATION

## 5.2 MECHANICAL REQUIREMENTS

	DESCRIPTION	TEST CONDITION	REQUIREMENT
	<b>Connector Mate Force</b>	Mate connector at a rate of <b>25 ± 6 mm (1 ± ¼ inch)</b> per minute. (Gage dimensions in Section 7.0)	<b>22 N (5 lbf)</b> unshielded MAXIMUM insertion force <b>35 N (8 lbf)</b> shielded MAXIMUM insertion force
	<b>Durability</b>	Mate connectors up to <b>500</b> cycles at a maximum rate of <b>10</b> cycles per minute prior to Environmental Tests.	<b>10</b> milliohms MAXIMUM (change from initial)
	<b>Vibration (Random)</b>	Amplitude: 1.50mm (.060") peak to peak Sweep: 10-55-10 Hz in one minute Duration: 15 minutes ±X,±Y,±Z axis (45 minutes total)	<b>10</b> milliohms MAXIMUM (change from initial) & Discontinuity < <b>1</b> microsecond
	<b>Plug Retention Force</b>	Apply an axial pullout force on the plug at a rate of <b>25 ± 6 mm (1 ± ¼ inch)</b> per minute.	<b>89 N (20 lbf)</b> MINIMUM retention force
	<b>PCB Separation Forces</b>	Apply a perpendicular load on the plug at a rate of <b>25 ± 6 mm (1 ± ¼ inch)</b> per minute.	<b>4.5 N (1 lbf)</b> MINIMUM withdrawal force before solder reflow <b>89 N (20 lbf)</b> MINIMUM withdrawal force after solder reflow
	<b>Shock (Mechanical)</b>	Mate connectors and shock at <b>50 g's</b> with three saw tooth wave form shocks in the ±X,±Y,±Z axis (18 shocks total).	<b>10</b> milliohms MAXIMUM (change from initial) & Discontinuity < <b>1</b> microsecond

<u>REVISION:</u> <b>H3</b>	<u>ECR/ECN INFORMATION:</u> EC No: <b>UCP2012-3129</b> DATE: <b>2012/03/22</b>	<u>TITLE:</u> <b>PRODUCT SPECIFICATION INVERTED RIGHT ANGLE MODULAR JACKS</b>	<u>SHEET No.</u> <b>3 of 5</b>
<u>DOCUMENT NUMBER:</u> <b>PS-43860-003</b>	<u>CREATED / REVISED BY:</u> <b>NNGUYEN</b>	<u>CHECKED BY:</u> <b>JBELL</b>	<u>APPROVED BY:</u> <b>FSMITH</b>



# PRODUCT SPECIFICATION

## 5.3 ENVIRONMENTAL REQUIREMENTS

	DESCRIPTION	TEST CONDITION	REQUIREMENT
	<b>Shock (Thermal)</b>	Mate connectors; expose to <b>10</b> cycles of: <b>-40°C to +85°C</b> <b>30</b> minutes dwell	<b>10</b> milliohms <b>MAXIMUM</b> (change from initial) & Visual: No Damage
	<b>Thermal Aging</b>	Mate connectors; expose to: <b>240</b> hours at <b>85±2°C</b>	<b>10</b> milliohms <b>MAXIMUM</b> (change from initial) & Visual: No Damage
	<b>Humidity (Cyclic)</b>	Mate connectors: expose to <b>10</b> cycles at <b>90-95%</b> relative humidity with temperatures at <b>+25°C</b> and <b>+65°C</b> per MIL-STD-202F method 106F (without -10°C dip)	<b>10</b> milliohms <b>MAXIMUM</b> (change from initial) & Dielectric Withstanding Voltage: No Breakdown at <b>500 VAC</b> & Insulation Resistance: <b>200</b> Megohms <b>MINIMUM</b> & Visual: No Damage
	<b>Solder Resistance</b>	Dip connector terminal tails in solder: Solder Duration: <b>7±0.5</b> seconds Solder Temperature: <b>260±5°C</b>  {Recommended same parameters as <b>SMES-152.</b> }  Note: The solder resistance test simulates a wave solder process. This test should not be used to determine the suitability of the connector for a convection or IR reflow solder process.	Visual: No Damage to insulator material

<u>REVISION:</u> <b>H3</b>	<u>ECR/ECN INFORMATION:</u> EC No: <b>UCP2012-3129</b> DATE: <b>2012/03/22</b>	<u>TITLE:</u> <b>PRODUCT SPECIFICATION INVERTED RIGHT ANGLE MODULAR JACKS</b>	<u>SHEET No.</u> <b>4 of 5</b>
<u>DOCUMENT NUMBER:</u> <b>PS-43860-003</b>	<u>CREATED / REVISED BY:</u> <b>NNGUYEN</b>	<u>CHECKED BY:</u> <b>JBELL</b>	<u>APPROVED BY:</u> <b>FSMITH</b>



# PRODUCT SPECIFICATION

## 6.0 PACKAGING

Parts shall be packaged to protect against damage during handling, transit and storage.  
See appropriate sales drawings on Sheet 1 for packaging descriptions.

## 7.0 GAGES AND FIXTURES

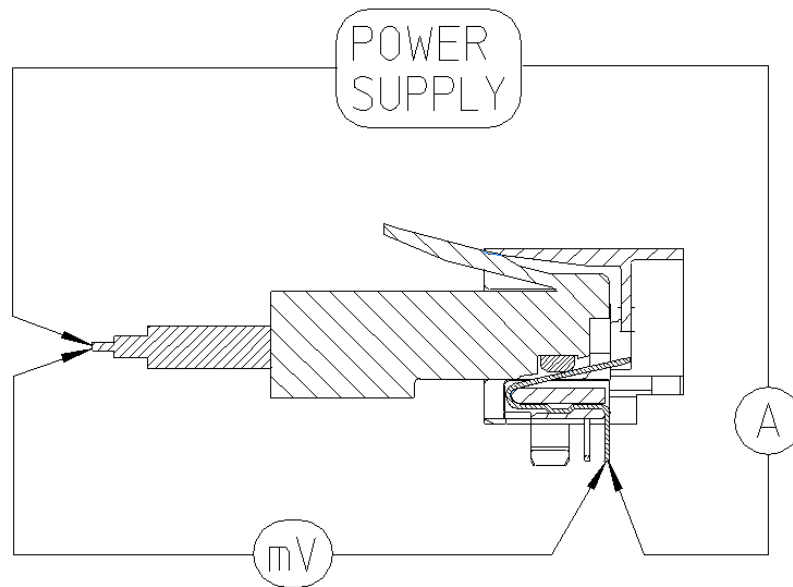

### TERMINATION RESISTANCE MEASUREMENT POINTS

Connector and plug terminals and wire conductor bulk resistance to be subtracted from measurements

## 8.0 OTHER INFORMATION

REVISION: <b>H3</b>	ECR/ECN INFORMATION: EC No: <b>UCP2012-3129</b> DATE: <b>2012/03/22</b>	TITLE: <b>PRODUCT SPECIFICATION INVERTED RIGHT ANGLE MODULAR JACKS</b>	SHEET No. <b>5 of 5</b>
DOCUMENT NUMBER: <b>PS-43860-003</b>	CREATED / REVISED BY: <b>NNGUYEN</b>	CHECKED BY: <b>JBELL</b>	APPROVED BY: <b>FSMITH</b>