

Mating Condition (REF.)

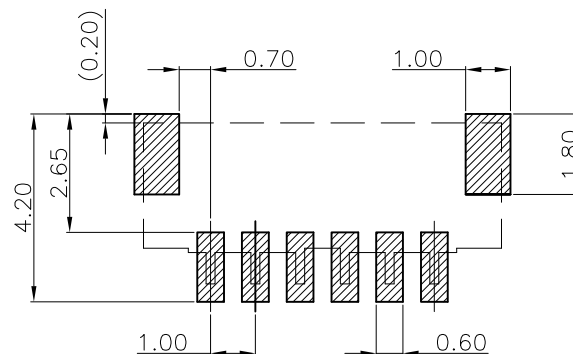

TOLERANCE: ± 0.05
RECOMMENDED P.C.B. Layout
TOP VIEW

NO. OF WAYS	PART NO.	Dim.(mm)	
		A	B
2	M40-3010246R	1.00	4.00
3	M40-3010346R	2.00	5.00
4	M40-3010446R	3.00	6.00
5	M40-3010546R	4.00	7.00
6	M40-3010646R	5.00	8.00
7	M40-3010746R	6.00	9.00
8	M40-3010846R	7.00	10.00
9	M40-3010946R	8.00	11.00
10	M40-3011046R	9.00	12.00
11	M40-3011146R	10.00	13.00
12	M40-3011246R	11.00	14.00
13	M40-3011346R	12.00	15.00
14	M40-3011446R	13.00	16.00
15	M40-3011546R	14.00	17.00
16	M40-3011646R	15.00	18.00
17	M40-3011746R	16.00	19.00
18	M40-3011846R	17.00	20.00
19	M40-3011946R	18.00	21.00
20	M40-3012046R	19.00	22.00

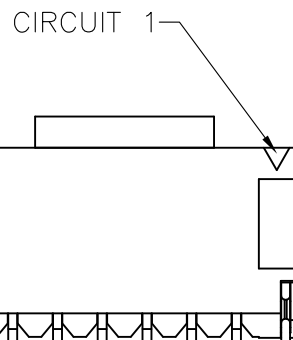
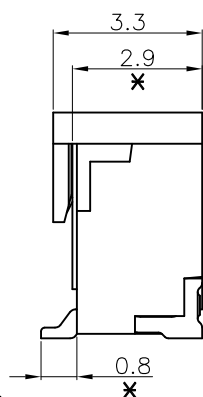
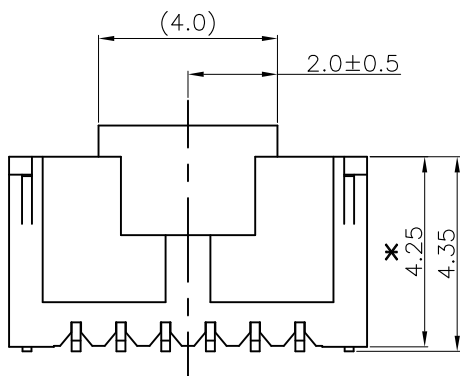

SPECIFICATIONS:

MATERIAL:

INSULATION: LCP, UL94V-0 (HALOGEN FREE); COLOR: CREAM.
CONTACT: COPPER ALLOY, $t=0.20\text{mm}$.

FINISH:

MATTE-TIN PLATED OVER NICKEL

ELECTRICAL:

CURRENT RATING: 1A AC/DC
WORKING VOLTAGE: 50V AC/DC
WITHSTAND VOLTAGE: 500V AC/MINUTE
CONTACT RESISTANCE: 30 m Ω MAX.
INSULATION RESISTANCE: 100 M Ω MIN.

ENVIRONMENTAL:

TEMPERATURE RANGE: -25°C TO $+85^{\circ}\text{C}$

Leo	5	08.02.18	A531
Allan	4	29.09.08	A164
Allan	3	27.06.08	A136
Allan	2	19.06.08	A130
Allan	1	01.08.06	--

NAME	ISS.	DATE	C/NOTE
------	------	------	--------

APPROVED: B.Lim

CHECKED: D.P

DRAWN: Leo

CUSTOMER REF.:

ASSEMBLY DRG:

#NOTE: REMOVE R FOR LOOSE BAG PACKING

ORDER CODE

M40-301 XX 46R

NO. OF WAYS WITH R: REEL PACKING

WITHOUT R: LOOSE BAG PACKING
(10 PCS PER STRIP, 10 STRIPS PER BAG)

OBSOLETE
Loose (without R)

NOTE: ALL DIMENSIONS AND NOTES MARKED * ARE CRITICAL AND MUST BE CHECKED IN ACCORDANCE WITH QUALITY DOC. QI-02A

HARWIN

HARWIN USA
TEL: 603 893 5376
FAX: 603 893 5396
mis@harwin.com

HARWIN Europe (UK)
TEL: 023 9231 4545
FAX: 023 9231 4590
mis@harwin.co.uk

HARWIN Asia
TEL: +65 6 779 4909
FAX: +65 6 779 3868
mis@harwin.com.sg

THIS DRAWING AND ANY INFORMATION OR DESCRIPTIVE MATTER SET OUT HEREON ARE CONFIDENTIAL AND COPYRIGHT PROPERTY OF THE HARWIN GROUP AND MUST NOT BE DISCLOSED, LOANED, COPIED OR USED FOR MANUFACTURING, TENDERING OR FOR ANY OTHER PURPOSE WITHOUT THEIR WRITTEN PERMISSION.

TOLERANCES

X. = $\pm 1\text{mm}$
X.X = $\pm 0.25\text{mm}$
X.XX = $\pm 0.15\text{mm}$
X.XXX = $\pm 0.08\text{mm}$

ANGLES = $\pm 5^{\circ}$

UNLESS STATED

MATERIAL:

SEE NOTES

FINISH:

SEE NOTES

S/AREA:

mm²

TITLE:

WAFER 1.00mm TOP ENTRY SMT TYPE

DRAWING NUMBER:

M40-301 XX 46 X

SHT
1
OF
2

Pin	Dim.(mm)				
	B0	F	S	W	W1
02	4.40	7.50	--	16.00	16.50
03	5.40				
04	6.40				
05	7.40				
06	8.40				
07	9.40	11.50	--	24.00	24.50
08	10.40				
09	11.40				
10	12.40				
11	13.40				
12	14.40	14.20	28.40	32.00	32.50
13	15.40				
14	16.40				
15	17.40				
16	18.40				
17	19.40	20.20	40.40	44.00	44.50
18	20.40				
19	21.40				
20	22.40				

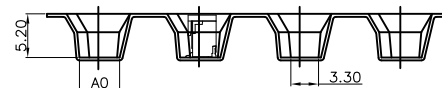
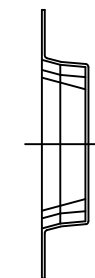
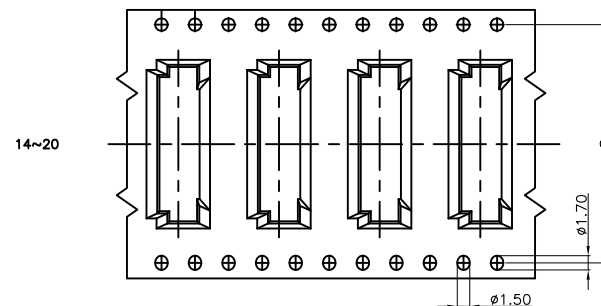
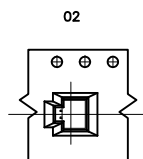
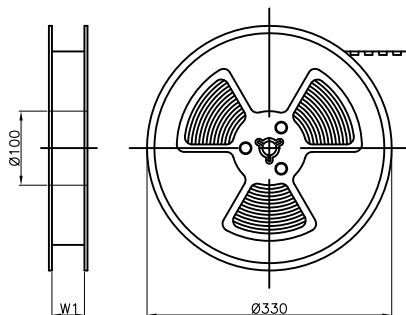
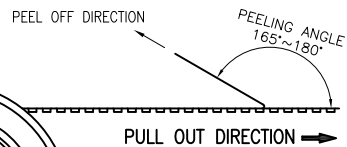
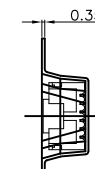
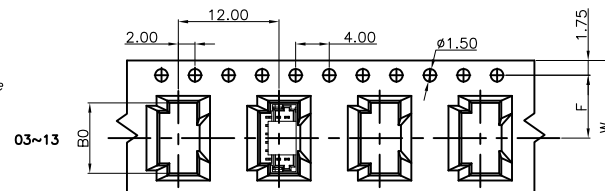
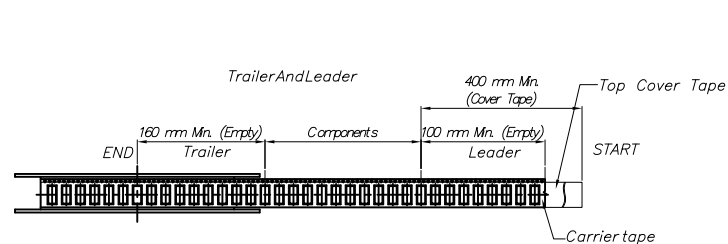

- 10 SPROCKET HOLE PITCH CUMULATIVE TOLERANCE ± 0.20
- CARRIER CAMBER IS WITHIN 1 mm IN 250 mm
- THE TOTAL TEARING CONTROL RANGE OF TOP COVER TAPE IS 10~130g, REFERENCE SPEC: EIA-481-D
- PEELING SPEED: 300mm/MINUTES, REFERENCE SPEC: EIA-481-D
- MATERIAL: TRANSPARENT CONDUCTIVE POLYSTYRENE ALLOY.(UP-5000)
- ALL DIMENSIONS MEET EIA-481-D REQUIREMENTS
- THICKNESS : 0.35 ± 0.05 mm
- COMPONENT LOAD PER 13" REEL : 1000 PCS

NOTE: ALL DIMENSIONS AND NOTES MARKED * ARE CRITICAL AND MUST BE CHECKED IN ACCORDANCE WITH QUALITY DOC. QI-02A

Leo	5	08.02.18	A531
Allan	4	29.09.08	A164
Allan	3	27.06.08	A136
Allan	2	19.06.08	A130
Allan	1	01.08.06	--

NAME	ISS.	DATE	C/NOTE
------	------	------	--------

APPROVED: B.Lim

CHECKED: D.P

DRAWN: Leo

CUSTOMER REF.:

ASSEMBLY DRG:

HARWIN

HARWIN USA
TEL: 603 893 5376
FAX: 603 893 5396
mis@harwin.com

HARWIN Europe (UK)
TEL: 023 9231 4545
FAX: 023 9231 4590
mis@harwin.co.uk

HARWIN Asia
TEL: +65 6 779 4909
FAX: +65 6 779 3868
mis@harwin.com.sg

THIS DRAWING AND ANY INFORMATION OR DESCRIPTIVE MATTER SET OUT HEREON ARE CONFIDENTIAL AND COPYRIGHT PROPERTY OF THE HARWIN GROUP AND MUST NOT BE DISCLOSED, LOANED, COPIED OR USED FOR MANUFACTURING, TENDERING OR FOR ANY OTHER PURPOSE WITHOUT THEIR WRITTEN PERMISSION.

TOLERANCES
X. = ± 1 mm
X.X = ± 0.25 mm
X.XX = ± 0.15 mm
X.XXX = ± 0.08 mm
ANGLES = $\pm 5^\circ$
UNLESS STATED

MATERIAL:
SEE NOTES
FINISH:
SEE NOTES
S/AREA:
mm²

TITLE:
WAFER 1.00mm TOP ENTRY SMT TYPE

DRAWING NUMBER:
M40-301 XX 46 X

SHT
2
OF
2