



GAS SENSORS : TYPE AD81

CO & NO₂ GAS SENSOR

PROVISIONAL DATA

DESCRIPTION:

Gas sensor made of thick film element.

FEATURES:

- Two sensing element on one chip: for CO(gasoline exhaust gas) and NO₂(diesel exhaust gas)
- Low influence of ambient atmosphere
- Typical applications include automatic damper in automotive cabin.

DATA:

Operating conditions:

Operating temperature..... -10 to + 55°C

Storage temperature..... -30 to + 85°C

Load Resistor R_L Variable

Heater resistance 19Ω (nom)

Rated power consumption P_s 20mW nom

Rated working voltage of circuit V_c

..... 5 ± 0.2V d.c.

..... 5 ± 0.2 Vrms a.c.

Parts and material:

Sensing element..... Semiconducting oxide

Thick film heater..... Platinum

Case..... Nylon 66

Pin..... Nickel alloy

Flame arrestor.....

.... Double 100-mesh stainless gauze(SUS316)

Sensitivity characteristics:

	Specification	Conditions
Output voltage in clean air	2 - 0.3 V	
Voltage change in gas	-0.5 - 0.15V	2ppm of NO ₂
Power consumption	620mW (nom)	

Mechanical characteristics:

Test	Condition	Performance
Vibration	Frequency:	10 - 500 Hz
	Amplitude (10 - 50Hz):	2 mm
	Acceleration (50 - 500 Hz)	10G
	Reciprical scanning time:	5 min
	Test time: 2 hours each for X, Y and Z directions	
Shock	Acceleration:	100G
	Number of impacts:	5

Should satisfy the specifications shown in the sensitivity characteristics

DIMENSIONS:

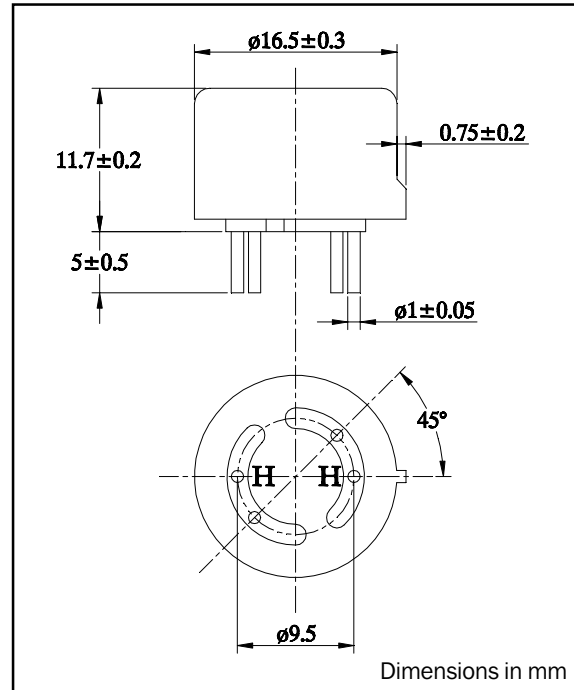

Typical gas sensitivity:

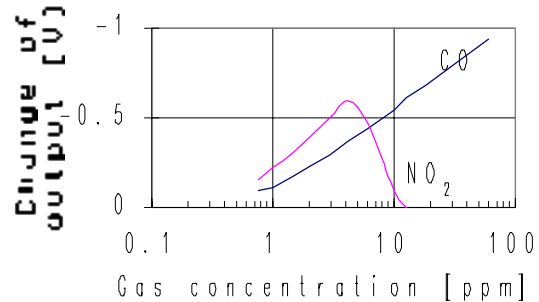

Data sheet D-AD81-1



GAS SENSORS : TYPE AD81

CO & NO₂ GAS SENSOR

PROVISIONAL DATA

NOTES:

Pin allocation and standard test circuit:

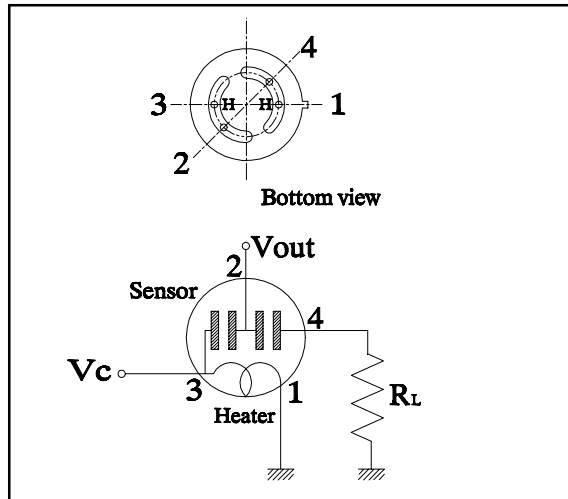

Test conditions:

Atmosphere

Clean air at $25 \pm 2^\circ\text{C}$ and $50 \pm 5\%$ RH without noise gas.

Circuit condition

V_c (circuit voltage) $5 \pm 0.05\text{V}$

R_L 340 to 1000Ω

Preheat time 24 hours

Test gas

NO₂ 2ppm

WARNING:

Do not use if the case or wire netting is damaged, otherwise built-in heater may cause explosions or fires.
Do not disassemble or change any parts.
Use only within specified conditions.

Data sheet D-AD81-1