

MATERIAL NUMBER	ENGINEERING NUMBER	AWG WIRE RANGE	LENGTH "L" MAX	PIN LENGTH "P" MIN (B1)	PIN DIAM. "D" ±.01/0.3	MWID	INSULATION COLOR	B MAX
192130001	WP-5210	12-10	1.24/31.5 (B1)	.35/8.9	.107/2.72	.22/5.6	YELLOW	.68/17.3
192130005	WP-5614	16-14	1.05/26.7	.35/8.9	.078/1.98	.17/4.3	BLUE	.55/14.0
192130003	WP-5218	22-18	1.05/26.7	.41/10.4	.078/1.98	.14/3.6	RED	.55/14.0

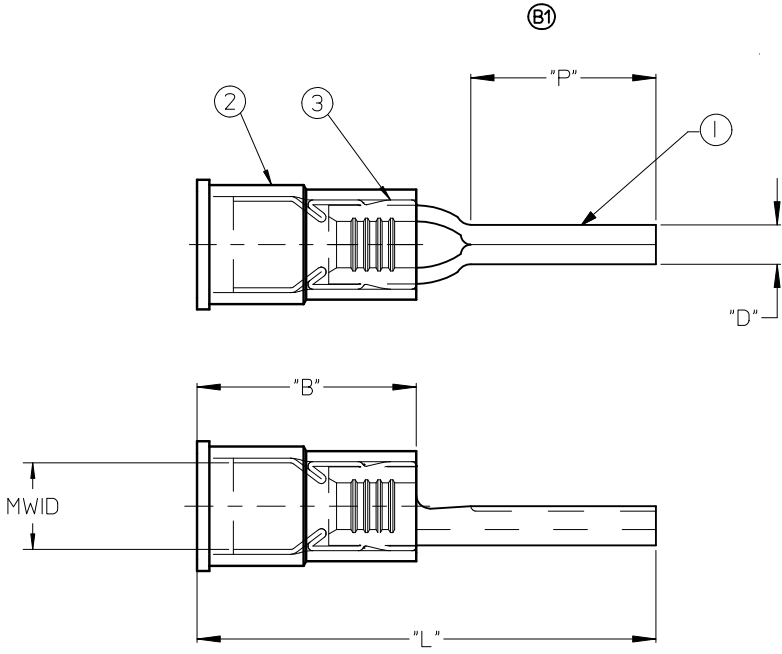

ITEM	QTY	DESCRIPTION	MATERIAL	FINISH
3	1	FERRULE PLATED	COPPER ALLOY	TIN PLATING
2	1	600V AVIK MLD INS	NYLON	SEE CHART
1	1	WIRE PIN KRIMPTITE	COPPER C11000	TIN PLATING

NOTES:

1. MATERIAL: SEE CHART
2. FINISH: SEE CHART
3. PARTS ARE ROHS COMPLIANT.
4. MWID = MAXIMUM WIRE INSULATION DIAMETER

CORRECT TOLERANCES EC NO: WNA2009-0437 DRW: WHEHRODAHL 2010/02/19 CHKD: JMACNEIL 2010/03/01 APPR: JMACNEIL 2010/03/18	QUALITY SYMBOLS	GENERAL TOLERANCES (UNLESS SPECIFIED)	DIMENSION STYLE	SCALE	DESIGN UNITS	THIRD ANGLE PROJECTION
	▽=0	mm INCH	IN/MM	4:1	INCH	
	▽=0	4 PLACES ±--- ±---	DRAWN BY DATE	TITLE AVIKRIMP WIRE PIN TERMINAL		
		3 PLACES ±--- ±---	ASAYDEH 06/03/17			
	2 PLACES ±--- ±---	CHECKED BY DATE	MOLEX INCORPORATED			
	1 PLACE ±--- ±---	RDEROSS 06/03/17				
	ANGULAR ±---°	APPROVED BY DATE	DOCUMENT NO. SD-19213-001			
		JMACNEIL 2010/03/18				
		MATERIAL NO.	SHEET NO. 1 OF 1			
		SEE CHART				
		SIZE B	THIS DRAWING CONTAINS INFORMATION THAT IS PROPRIETARY TO MOLEX INCORPORATED AND SHOULD NOT BE USED WITHOUT WRITTEN PERMISSION			