

Typical unit

FEATURES

- Support IEEE802.3at class4
- 25.5W DC-DC converter
- Support Type2 PSE Indicator
- Support Adapter ORing
- 37-57V Input Voltage range
- 22.4 x 35.5 x 10.55mm Size
- 92.5% efficiency (typical, 12Vout)
- Surface mount module
- 2250Vdc Input-Output Isolation
- Recognized UL 62368-1, 2nd Ed*.
Obtained IEC62368-1, 2nd Ed CB report*.

PRODUCT OVERVIEW

The MYBSP0122BABFT Series / MYBSP0055AABFT Series is an isolated, regulated, DC-DC converter for PoE PD that has an input range of 37-57Vdc with a typical efficiency of 92.5%(12Vout), and full 2250 Volt DC isolation.

The MYBSP0122BABFT Series / MYBSP0055AABFT Series is ideal for IEEE 802.3at Compliant Devices. Module has self-protection features. These include input undervoltage lockout and output current limit. The outputs current limit is using the hiccup autorestart technique.

And the module has detection and classification for compliant IEEE802.3at. MYBSP0122BABFT Series / MYBSP0055AABFT Series has three additional pins for Type2 PSE Indicator and Adapter ORing compared to MYBSP0122BABFT / MYBSP0055AABFT.

The PoE system has a function called Maintain Power Signature (MPS). This function allows PSE to detect the input current of the PD module. The input current of the PD module requires 10 mA or more.

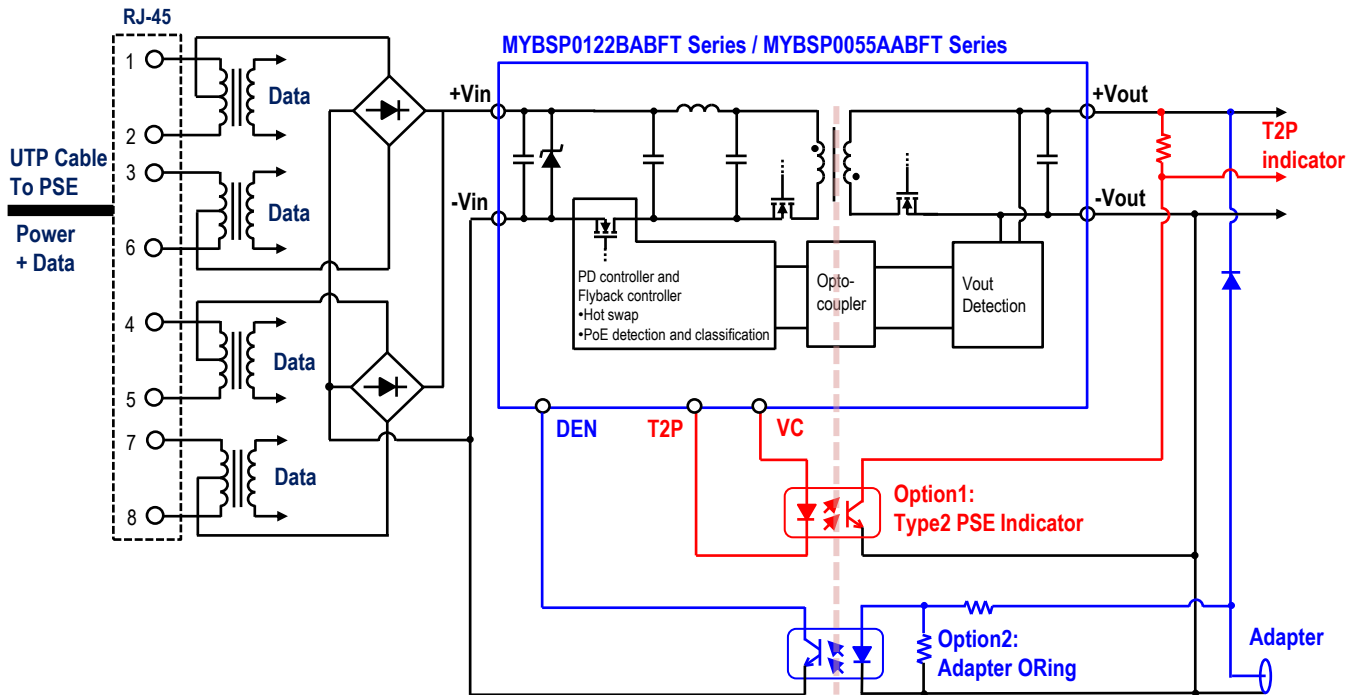
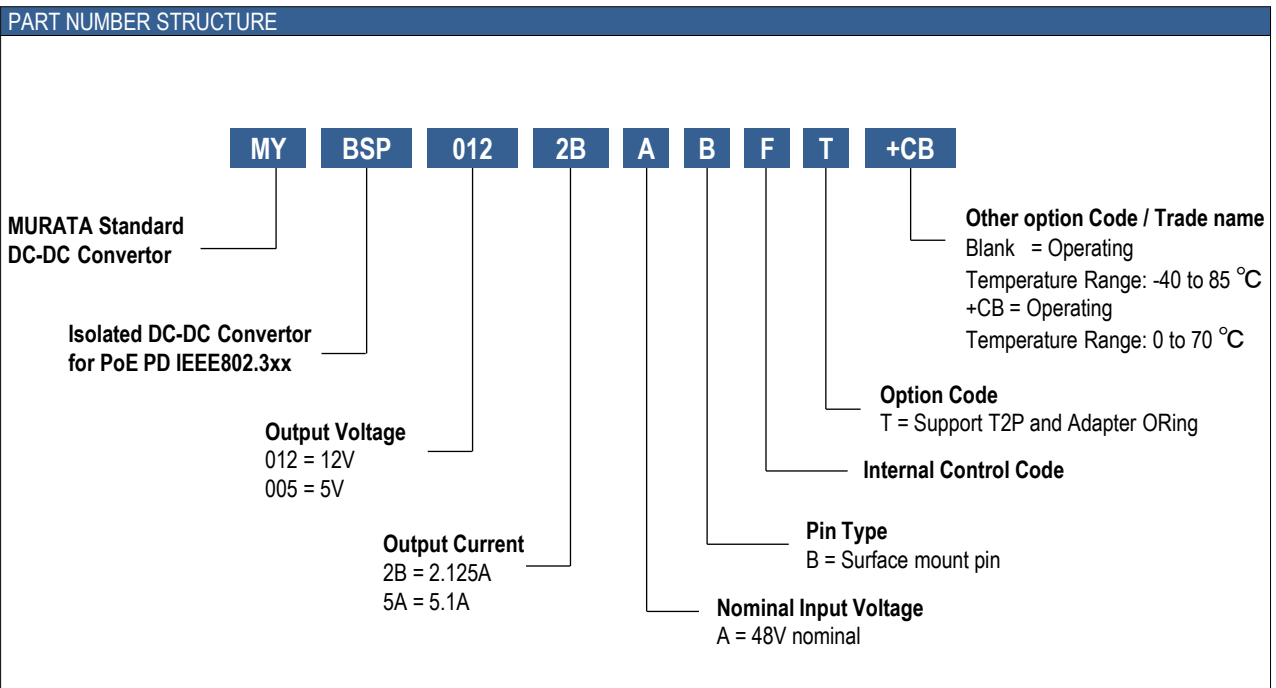

Figure 1. Simplified Block Diagram
Typical topology is shown.

| PERFORMANCE SPECIFICATIONS SUMMARY AND ORDERING GUIDE | | | | | | | | | | | | | |
|---|------------|---------------|-----------|------------------|-----------------|----------|----------------|-------------|-----------------------|------------------------|----------------|------|---------------------|
| Model Number | Output | | | | | | Input | | | | Efficiency (%) | | Package (mm) |
| | Vout (Vdc) | Iout (A,Max.) | Power (W) | R/N Max. (mVp-p) | Regulation Typ. | | Vin Nom. (Vdc) | Range (Vdc) | Iin, no load Typ.(mA) | Iin, full load Typ.(A) | Min. | Typ. | |
| | | | | | Line (%) | Load (%) | | | | | | | |
| MYBSP0122BABFT | 12 | 2.125 | 25.5 | 150 | ±0.1 | ±0.1 | 48 | 37-57 | 3 | 0.57 | 90 | 92.5 | 22.4 x 35.5 x 10.55 |
| MYBSP0122BABFT+CB | | | | | | | | | | | | | |
| MYBSP0055AABFT | 5 | 5.1 | 25.5 | 150 | ±0.1 | ±0.1 | 48 | 37-57 | 5 | 0.59 | 88 | 90.5 | |
| MYBSP0055AABFT+CB | | | | | | | | | | | | | |

1. Please refer to the Part Number Structure for additional ordering information and options.
2. All specifications are at nominal line voltage, full load, +25°C unless otherwise stated.



Product Marking

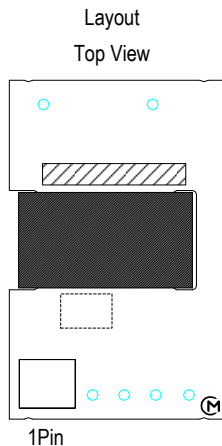

- Codes
- MFG ID
 - Model Number
 - Internal Manufacturing Code

FUNCTIONAL SPECIFICATIONS, MYBSP0122BABFT Series

| ABSOLUTE MAXIMUM RATINGS | Conditions | Minimum | Typical / Nominal | Maximum | Units |
|---|---|---------|-------------------|---------|-------------------------|
| Input Voltage, Continuous | | 0 | | 57 | Vdc |
| Input Voltage, Transient | 100ms max. duration | | | 60 | Vdc |
| Isolation Voltage | Input to output, Leak current 1mA max for 1minute at +25°C/60%RH. | | | 2250 | Vdc |
| Output Power | | 0 | | 25.5 | W |
| Output Current | Current-limited, no damage, short-circuit protected | 0 | | 2.125 | A |
| Storage Temperature Range | Vin = Zero (no power) | -40 | | 90 | °C |
| Absolute maximums are stress ratings. Exposure of devices to greater than any of these conditions may adversely affect long-term reliability. Proper operation under conditions other than those listed in the Performance/Functional Specifications Table is not implied or recommended. | | | | | |
| INPUT | | | | | |
| Operating Voltage Range | | 37 | 48 | 57 | Vdc |
| Start-up threshold | Rising input voltage | 36.1 | | 40.2 | Vdc |
| Undervoltage shutdown | Falling input voltage | 30.3 | | 33.8 | Vdc |
| Internal Filter Type | | | Pi | | |
| Input current | | | | | |
| Full Load Conditions | Vin = nom., Iout = max | | 0.57 | | A |
| Low Line Input current | Vin = min., Iout = max. | | 0.64 | | A |
| No Load Current | Vin = nom., Iout = 0A. | | 3 | | mA |
| On Resistance of Internal Hotswap | | | 0.45 | | Ω |
| Resistance for detection | Vin=2.7 to 10.1V | | 24.9 | | kΩ |
| Classification current | Vin=14.5 to 20.5V | | 40 | | mA |
| GENERAL and SAFETY | | | | | |
| Efficiency | Vin = 48V, full load | 90 | 92.5 | | % |
| Isolation | | | | | |
| Isolation Voltage | Input to output, Leak current 1mA max for 1minute at +25°C/60%RH. | 2250 | | | Vdc |
| Insulation Safety Rating | | | Functional | | |
| Isolation Capacitance | | | 1500 | | pF |
| Safety Certified to UL 62368-1, 2nd Ed *1 | | | Yes | | |
| Calculated MTBF | Telcordia SR-332, issue 1, class 3, ground fixed, Ta = +25°C | | 2476 | | Hours x 10 ³ |
| DYNAMIC CHARACTERISTIC | | | | | |
| Fixed Switching Frequency *2 | Iout = max | | 220 | | kHz |
| Vout Rise Time | From 10%-90% of Vout | | 10 | | ms |
| Dynamic Load Response | 50-100-50% load step to 1% of Vout | | 150 | | μSec |
| Dynamic Load Peak Deviation | same as above | | ±200 | | mVdc |

FUNCTIONAL SPECIFICATIONS, MYBSP0122BABFT Series(CONT.)

| OUTPUT | Conditions | Minimum | Typical / Nominal | Maximum | Units |
|--|---|---------|---------------------|---------|--------------|
| Total Output Power | | 0 | | 25.5 | W |
| Voltage | | | | | |
| Nominal Output Voltage | all conditions | 11.64 | 12 | 12.36 | Vdc |
| Overvoltage Protection | | | None | | Vdc |
| Current | | | | | |
| Output Current Range *3 | | 0 | | 2.125 | A |
| Current Limit Inception | | 2.2 | | | A |
| Short circuit protection method | Hiccup current limiting | | Non-latching | | |
| Regulation | | | | | |
| Line Regulation | Vin=min. to max., Vout=nom., full load | | ±0.1 | | % of Vout |
| Load Regulation | Iout = min. to max. | | ±0.1 | | % of Vout |
| Ripple and Noise | 150 MHz BW, Cout=1μF MLCC paralleled with 10μF | | | 150 | mV pk-pk |
| Temperature Coefficient | At all outputs | | ±0.02 | | % of Vout/°C |
| Maximum Capacitive Loading | Low ESR | 0 | | 400 | μF |
| T2P / VC / DEN | | | | | |
| T2P | | | | | |
| Sinking Current | After 2 event classification, T2P connect to VC | | 1.2 | | mA |
| VC | | | | | |
| Output Voltage | After start up | | 8.5 | 12 | V |
| DEN | | | | | |
| Output Voltage | DEN=open | | | +Vin | V |
| Output Current | DEN connect to -Vin | | | 5 | mA |
| Disable Voltage | Falling | | | 2.8 | V |
| MECHANICAL | | | | | |
| Outline Dimensions | L x W x H | | 22.4 x 35.5 x 10.55 | | mm |
| Weight | | | 13.3 | | Grams |
| Pin Diameter | | | 1.57 | | mm |
| Pin Material | | | Copper alloy | | |
| ENVIRONMENTAL | | | | | |
| Operating Ambient Temperature Range | MYBSP0122BABFT | -40 | | 85 | °C |
| | MYBSP0122BABFT+CB | 0 | | 70 | °C |
| Storage Temperature | Vin = Zero (no power) | -40 | | 90 | °C |
| Thermal Protection/Shutdown | Measured at hotspot | | None | | °C |
| Electromagnetic Interference Radiated, EN55022/CISPR22 | External filter is required | | B | | Class |

Specification Notes

Unless otherwise noted, all specifications are typical at nominal input voltage, nominal output voltage and full load. General conditions are +25°C ambient temperature, near sea level altitude, natural convection airflow. All models are tested and specified with external parallel 0.1μF and 10μF output capacitors (See Technical Notes).

*1 The certified model name of the safety standard is MYBSP0122BABFT.

*2 Variable frequency operation at light load.

*3 Input current must be greater than or equal to 10mA if your application applies Maintain Power Signature(MPS) by IEEE802.3at. Please check with your application.

PERFORMANCE DATA, MYBSP0122BABFT Series

Efficiency vs. Line Voltage and Load Current
($T_a=+25^\circ\text{C}$)

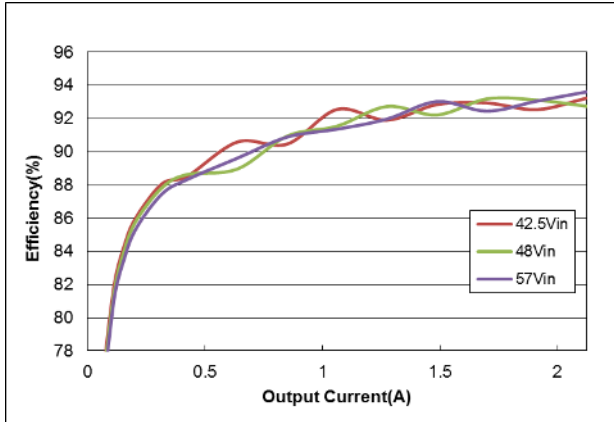

Load Regulation ($T_a=+25^\circ\text{C}$)

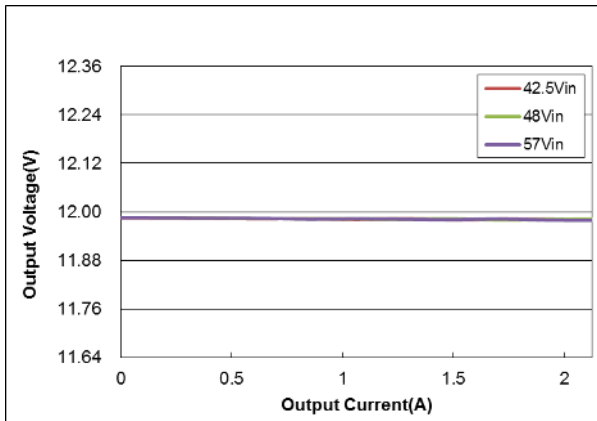

V_{out} Start-up
($V_{in}=48\text{V}$, $I_{out}=2.125\text{A}$, $T_a=+25^\circ\text{C}$)

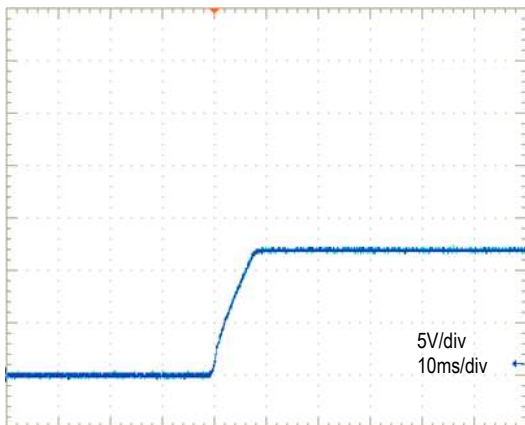

Output Ripple and Noise
($V_{in}=48\text{V}$, $I_{out}=2.125\text{A}$, $T_a=+25^\circ\text{C}$)

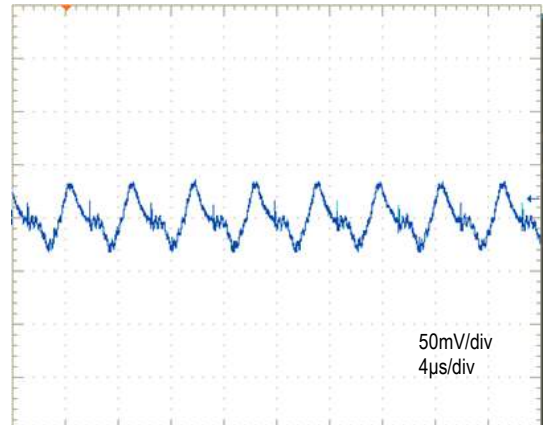

Transient Response ($V_{in}=48\text{V}$, $I_{out}=1.06\text{A}$ to 2.125A , $T_a=+25^\circ\text{C}$)
Ch2=V_{out}, 200mV/div, Ch4=I_{out}, 1A/div

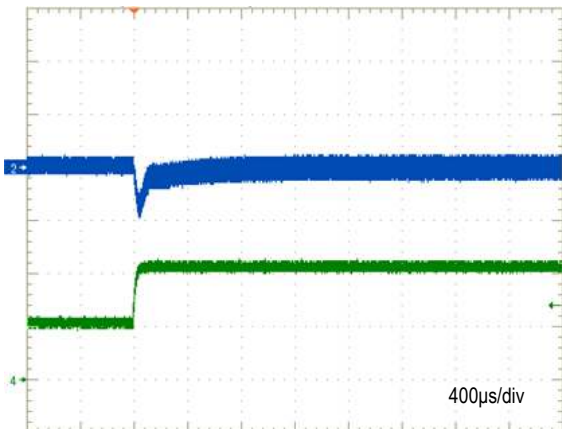

Transient Response ($V_{in}=48\text{V}$, $I_{out}=2.125\text{A}$ to 1.06A , $T_a=+25^\circ\text{C}$)
Ch2=V_{out}, 200mV/div, Ch4=I_{out}, 1A/div



PERFORMANCE DATA, MYBSP0122BABFT Series(CONT.)

Radiation Noise ($V_{in}=48V$, $I_{out}=2.125A$, $T_a=+25^{\circ}C$)
with External Input Filter

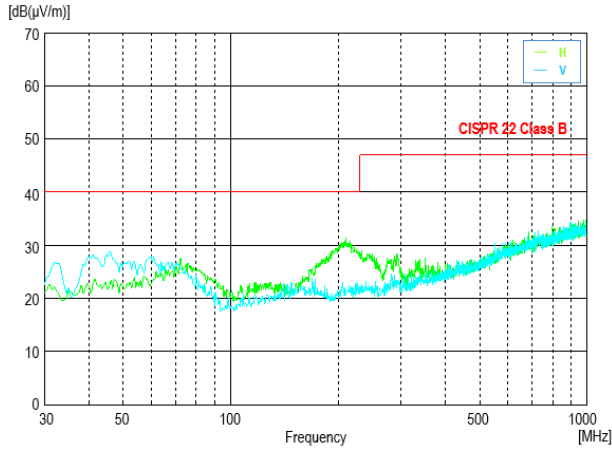

Thermal Derating
Unit under test (UUT) is covered by acrylic box to avoid airflow.
($V_{in}=42.5-57V$, See Technical Notes)

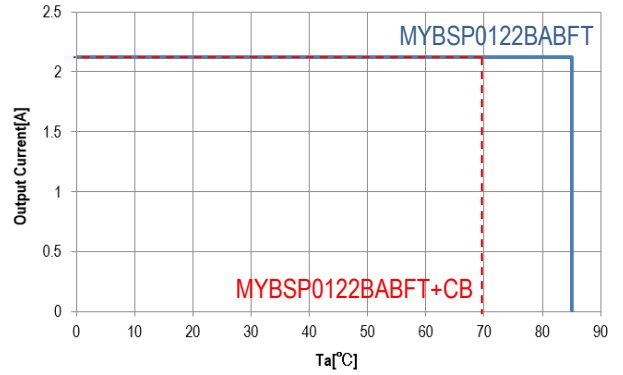

FUNCTIONAL SPECIFICATIONS, MYBSP0055AABFT Series

| ABSOLUTE MAXIMUM RATINGS | Conditions | Minimum | Typical / Nominal | Maximum | Units |
|---|---|---------|-------------------|---------|-------------------------|
| Input Voltage, Continuous | | 0 | | 57 | Vdc |
| Input Voltage, Transient | 100ms max. duration | | | 60 | Vdc |
| Isolation Voltage | Input to output, Leak current 1mA max for 1minute at +25°C/60%RH. | | | 2250 | Vdc |
| Output Power | | 0 | | 25.5 | W |
| Output Current | Current-limited, no damage, short-circuit protected | 0 | | 5.1 | A |
| Storage Temperature Range | Vin = Zero (no power) | -40 | | 90 | °C |
| Absolute maximums are stress ratings. Exposure of devices to greater than any of these conditions may adversely affect long-term reliability. Proper operation under conditions other than those listed in the Performance/Functional Specifications Table is not implied or recommended. | | | | | |
| INPUT | | | | | |
| Operating Voltage Range | | 37 | 48 | 57 | Vdc |
| Start-up threshold | Rising input voltage | 36.1 | | 40.2 | Vdc |
| Undervoltage shutdown | Falling input voltage | 30.3 | | 33.8 | Vdc |
| Internal Filter Type | | | Pi | | |
| Input current | | | | | |
| Full Load Conditions | Vin = nom., Iout = max | | 0.59 | | A |
| Low Line Input current | Vin = min., Iout = max. | | 0.67 | | A |
| No Load Current | Vin = nom., Iout = 0A. | | 5 | | mA |
| On Resistance of Internal Hotswap | | | 0.45 | | Ω |
| Resistance for detection | Vin=2.7 to 10.1V | | 24.9 | | kΩ |
| Classification current | Vin=14.5 to 20.5V | | 40 | | mA |
| GENERAL and SAFETY | | | | | |
| Efficiency | Vin = 48V, full load | 88 | 90.5 | | % |
| Isolation | | | | | |
| Isolation Voltage | Input to output, Leak current 1mA max for 1minute at +25°C/60%RH. | 2250 | | | Vdc |
| Insulation Safety Rating | | | Functional | | |
| Isolation Capacitance | | | 1500 | | pF |
| Safety Certified to UL 62368-1, 2nd Ed *1 | | | Yes | | |
| Calculated MTBF | Telcordia SR-332, issue 1, class 3, ground fixed, Ta = +25°C, | | 2476 | | Hours x 10 ³ |
| DYNAMIC CHARACTERISTIC | | | | | |
| Fixed Switching Frequency *2 | Iout = max | | 220 | | kHz |
| Vout Rise Time | From 10%-90% of Vout | | 5 | | ms |
| Dynamic Load Response | 50-100-50% load step to 1% of Vout | | 150 | | μSec |
| Dynamic Load Peak Deviation | same as above | | ±100 | | mVdc |

FUNCTIONAL SPECIFICATIONS, MYBSP0055AABFT Series(CONT.)

| OUTPUT | Conditions | Minimum | Typical / Nominal | Maximum | Units |
|--|---|---------|---------------------|---------|--------------|
| Total Output Power | | 0 | | 25.5 | W |
| Voltage | | | | | |
| Nominal Output Voltage | all conditions | 4.85 | 5 | 5.15 | Vdc |
| Oversvoltage Protection | | | None | | Vdc |
| Current | | | | | |
| Output Current Range *3 | | 0 | | 5.1 | A |
| Current Limit Inception | | 5.3 | | | A |
| Short circuit protection method | Hiccup current limiting | | Non-latching | | |
| Regulation | | | | | |
| Line Regulation | Vin=min. to max., Vout=nom., full load | | ±0.1 | | % of Vout |
| Load Regulation | Iout = min. to max. | | ±0.1 | | % of Vout |
| Ripple and Noise | 150 MHz BW, Cout=1µF MLCC paralleled with 10µF | | | 150 | mV pk-pk |
| Temperature Coefficient | At all outputs | | ±0.02 | | % of Vout/°C |
| Maximum Capacitive Loading | Low ESR | 0 | | 400 | µF |
| T2P / VC / DEN | | | | | |
| T2P | | | | | |
| Sinking Current | After 2 event classification, T2P connect to VC | | 1.2 | | mA |
| VC | | | | | |
| Output Voltage | After start up | | 8.5 | 12 | V |
| DEN | | | | | |
| Output Voltage | DEN=open | | | +Vin | V |
| Output Current | DEN connect to -Vin | | | 5 | mA |
| Disable Voltage | Falling | | | 2.8 | V |
| MECHANICAL | | | | | |
| Outline Dimensions | L x W x H | | 22.4 x 35.5 x 10.55 | | mm |
| Weight | | | 13.3 | | Grams |
| Pin Diameter | | | 1.57 | | mm |
| Pin Material | | | Copper alloy | | |
| ENVIRONMENTAL | | | | | |
| Operating Ambient Temperature Range | MYBSP0055AABFT | -40 | | 85 | °C |
| | MYBSP0055AABFT+CB | 0 | | 70 | °C |
| Storage Temperature | Vin = Zero (no power) | -40 | | 90 | °C |
| Thermal Protection/Shutdown | Measured at hotspot | | None | | °C |
| Electromagnetic Interference Radiated, EN55022/CISPR22 | External filter is required | | B | | Class |

Specification Notes

Unless otherwise noted, all specifications are typical at nominal input voltage, nominal output voltage and full load. General conditions are +25°C ambient temperature, near sea level altitude, natural convection airflow. All models are tested and specified with external parallel 0.1µF and 10µF output capacitors (See Technical Notes).

*1 The certified model name of the safety standard is MYBSP0055AABFT.

*2 Variable frequency operation at light load.

*3 Input current must be greater than or equal to 10mA if your application applies Maintain Power Signature(MPS) by IEEE802.3at. Please check with your application.

PERFORMANCE DATA, MYBSP0055AABFT Series

Efficiency vs. Line Voltage and Load Current
(Ta=+25°C)

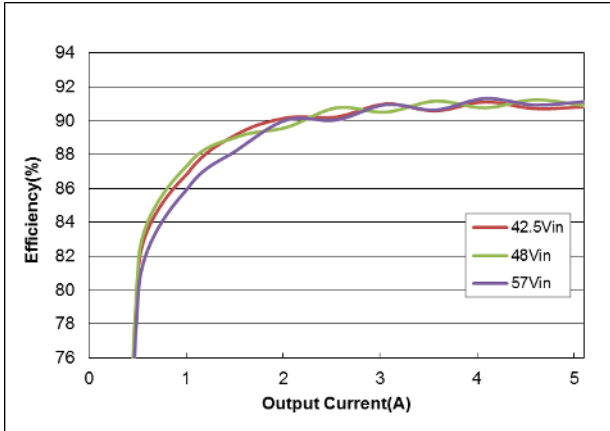

Load Regulation (Ta=+25°C)

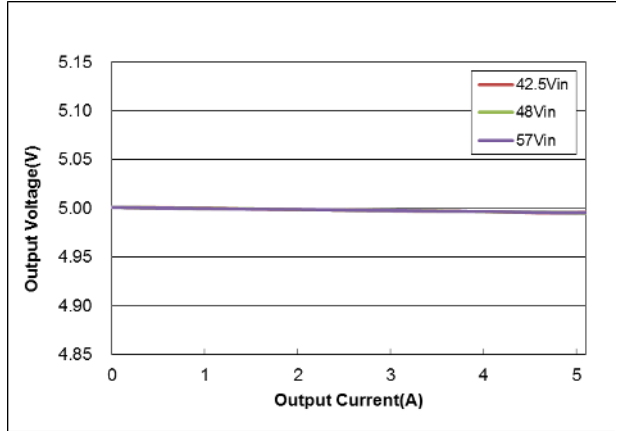

Vout Start-up
(Vin=48V, Iout=5.1A, Ta=+25°C)

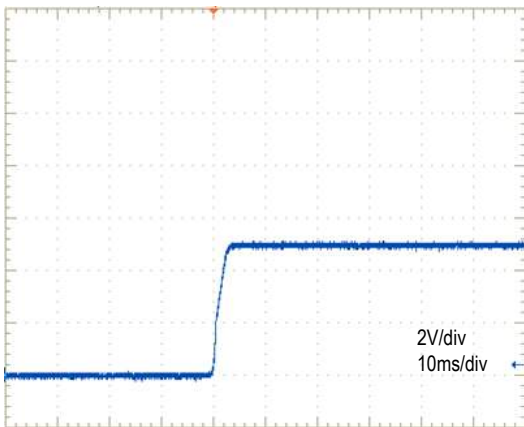

Output Ripple and Noise
(Vin=48V, Iout=5.1A, Ta=+25°C)

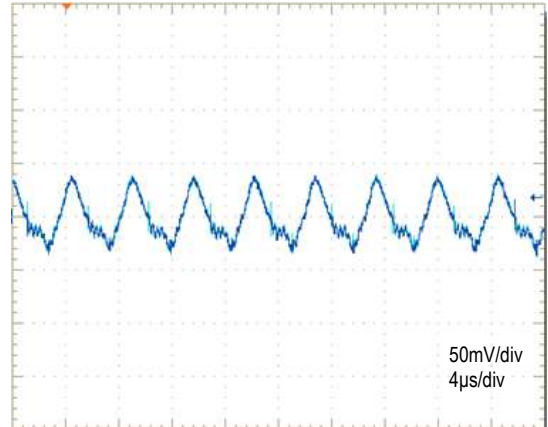

Transient Response (Vin=48V, Iout=2.55A to 5.1A, Ta=+25°C)
Ch3=Vout, 200mV/div, Ch4=Iout, 2A/div

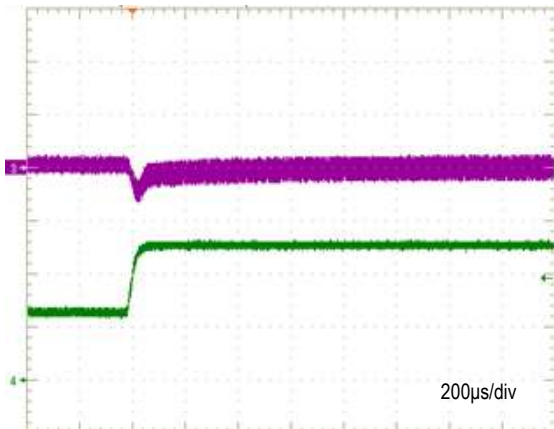

Transient Response (Vin=48V, Iout=2.55A to 5.1A, Ta=+25°C)
Ch3=Vout, 200mV/div, Ch4=Iout, 2A/div

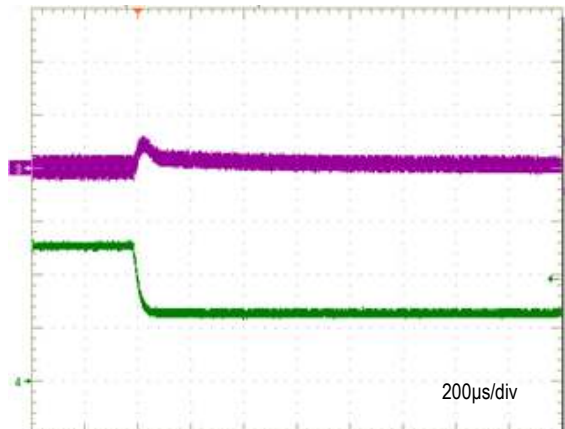

PERFORMANCE DATA, MYBSP0055AABFT Series(CONT.)

Radiation Noise (Vin=48V, Iout=5.1A, Ta=+25°C)
with External Input Filter

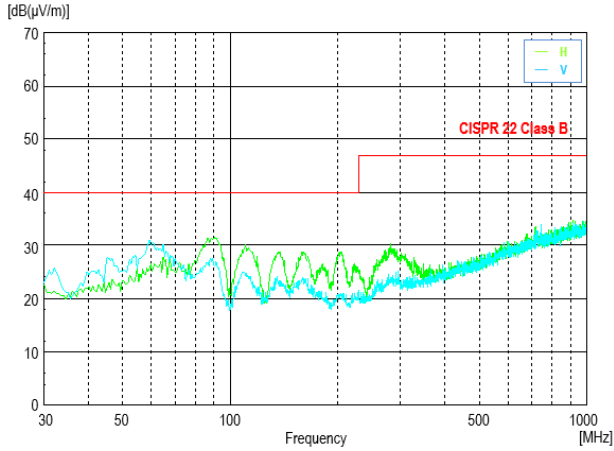

Thermal Derating
Unit under test (UUT) is covered by acrylic box to avoid airflow.
(Vin=42.5-57V, See Technical Notes)

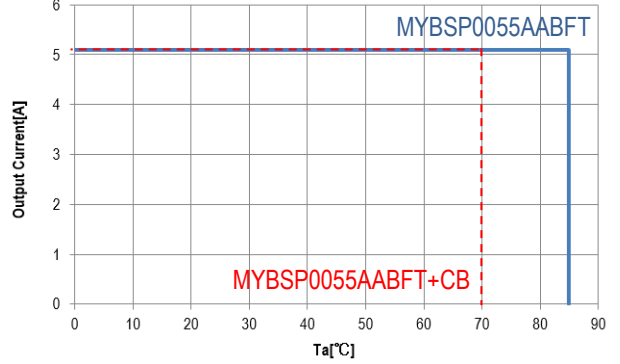

MECHANICAL SPECIFICATIONS

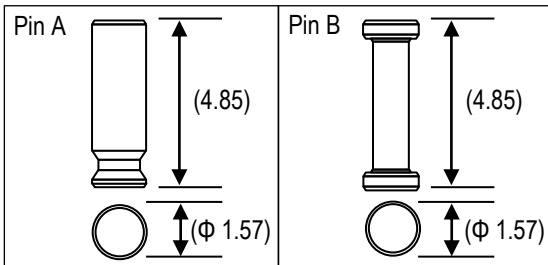
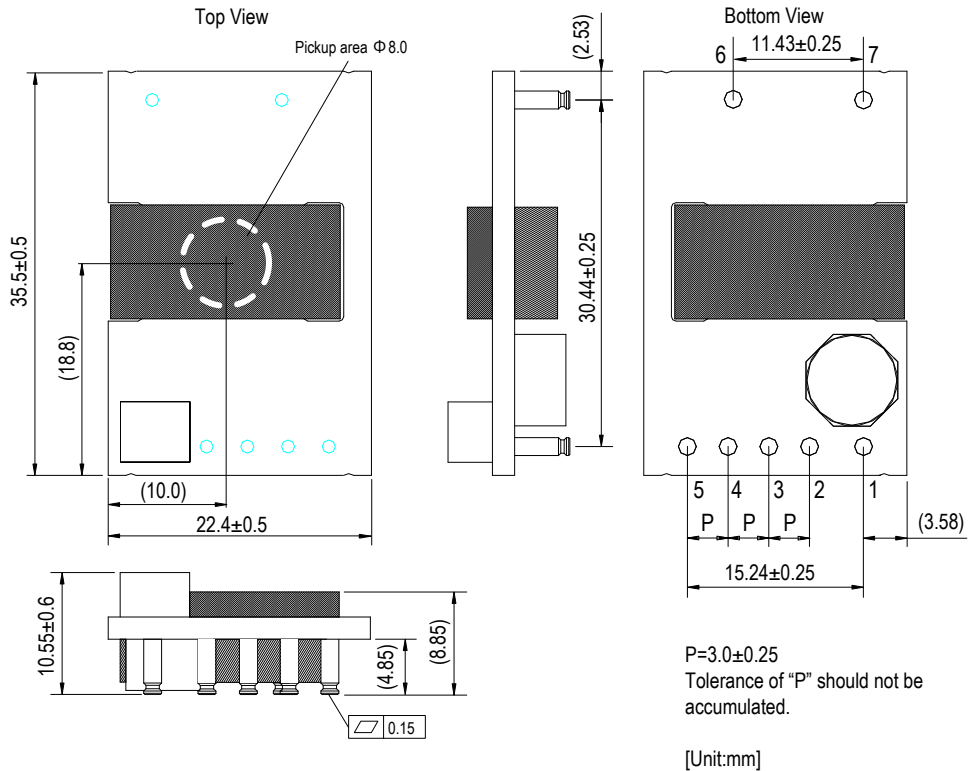

*Pin would be used either Pin A or Pin B.

| INPUT / OUTPUT CONNECTIONS | | | |
|----------------------------|-------------|-------------------------|-------------|
| Pin | Designation | Function | Pin size |
| 1 | +Vin | Positive Input Voltage | $\Phi 1.57$ |
| 2 | DEN | Detection and Enable | $\Phi 1.57$ |
| 3 | T2P | Type-2 PSE Indicator | $\Phi 1.57$ |
| 4 | VC | Controller Voltage | $\Phi 1.57$ |
| 5 | -Vin | Negative Input Voltage | $\Phi 1.57$ |
| 6 | -Vout | Negative Output Voltage | $\Phi 1.57$ |
| 7 | +Vout | Positive Output Voltage | $\Phi 1.57$ |

RECOMMENDED FOOTPRINT (TOP VIEW)

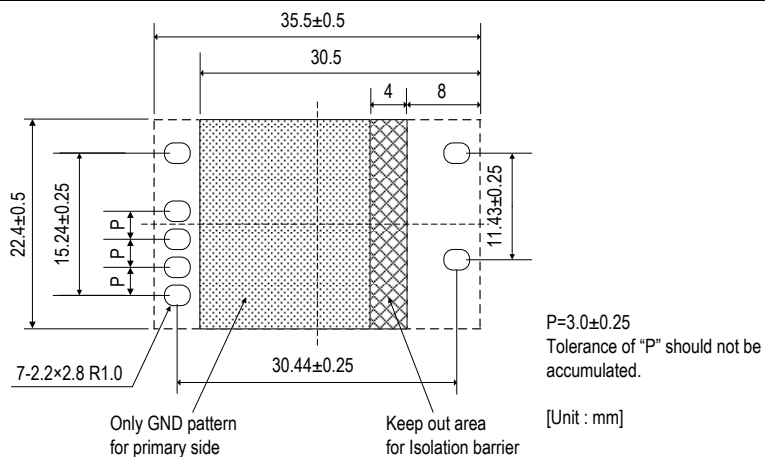

*Do not place parts in areas under the product.

Lay out high-impedance wiring such as signal lines as far away from the product as possible.

PACKAGING INFORMATION (SURFACE MOUNT, MSL Rating 2 Equivalent)

Packaging form
The products are placed in the Emboss Tape as below

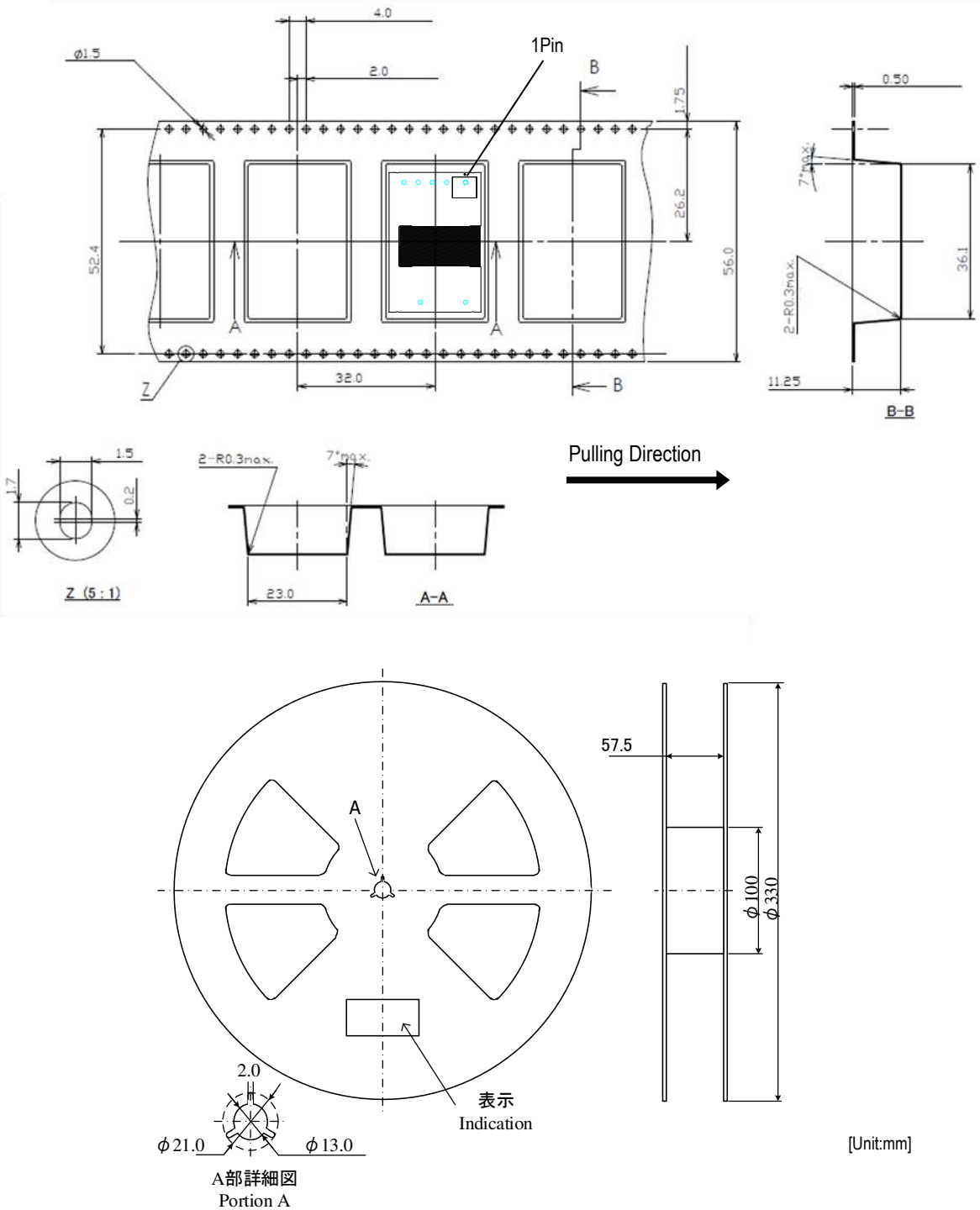

PACKAGING INFORMATION (SURFACE MOUNT, MSL Rating 2 Equivalent)

Packaging form
Taping Specification

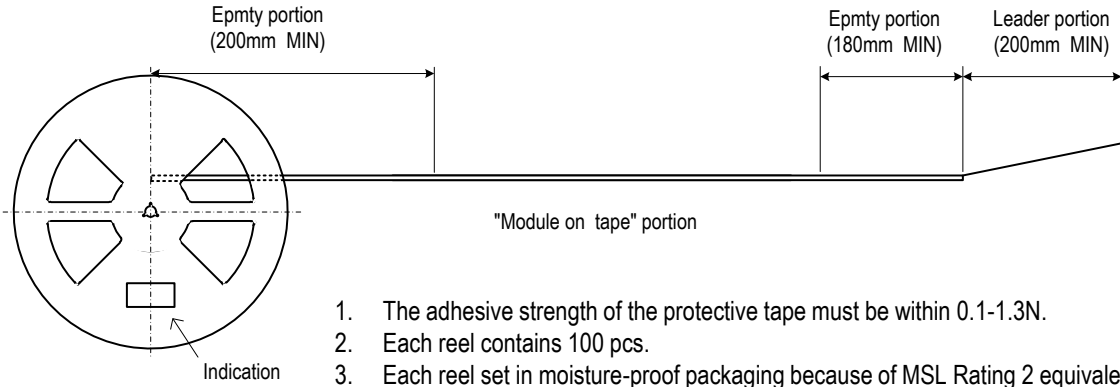

1. The adhesive strength of the protective tape must be within 0.1-1.3N.
2. Each reel contains 100 pcs.
3. Each reel set in moisture-proof packaging because of MSL Rating 2 equivalent.
4. The deficiency per reel is 0 piece.
5. The reel shows customer part number, Murata part number and quantity.
6. The color of reel is not designated.

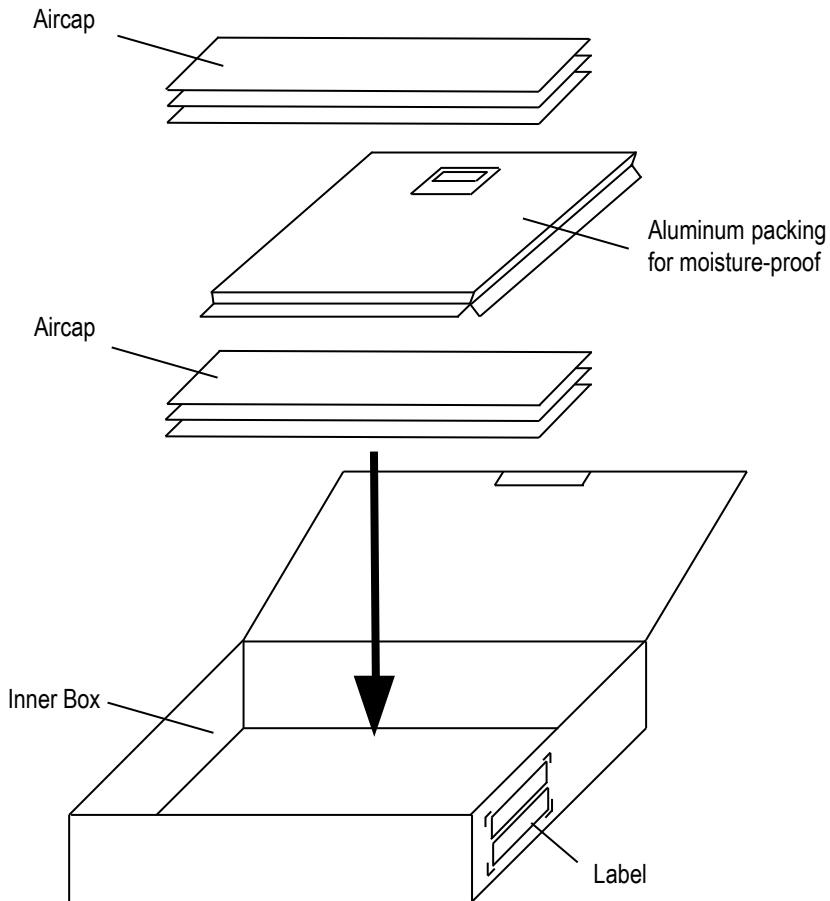

TECHNICAL NOTES

Over Current Protection

Over Current Protection operates with a controller circuit failure or over-load condition, and DC-DC converter will enter hiccup mode. After rejected the abnormal mode, DC-DC converter will automatically restart.

External Input Capacitor

Do not connect any capacitor between positive input and negative input to avoid large inrush current. It is one of the requirements of IEEE802.3at standard.

Test Circuit

The initial values in Functional Specification are measured in the following test circuit.

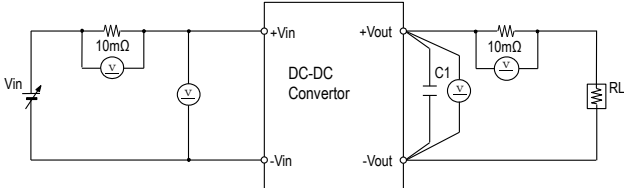

- C1 : Ceramic Capacitor 0~400μF
- RL : Electronic Load Device : LN-1000A-G7 KEISOKU GIKEN equivalent
- Vin : DC Power Supply :Model HP6675A KEYSIGHT equivalent
- Ⓜ : Digital Multimeter :Model HP34401A KEYSIGHT equivalent

When deviating from the above, DC-DC converter may operate abnormally. It should be fully confirmed on your board before use.

Ripple Noise Test

Output ripple noise is measured using designated external output components, circuits and layout as shown below.

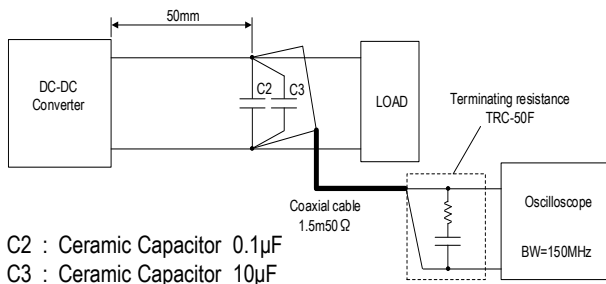

- C2 : Ceramic Capacitor 0.1μF
- C3 : Ceramic Capacitor 10μF

Radiation Noise

The external input filter is installed and the circuit diagram is shown below.

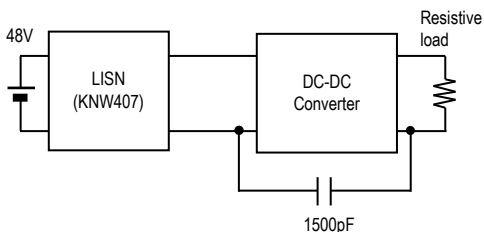

Type2 PSE Indicator

T2P(Pin3) is open drain output. After 2 event classification, MYBSP0122BABFT Series / MYBSP0055AABFT Series pulls T2P low. Please pull up T2P by VC(Pin4). VC is source only for T2P. Do not apply VC for any other purpose. Appropriate board design for isolation barrier is required(Opto-coupler selection and Isolation distance). Also consider CTR of Opto-coupler which may affect value of R1. Keep T2P and VC open if you don't apply this function. Typical application circuit is below.

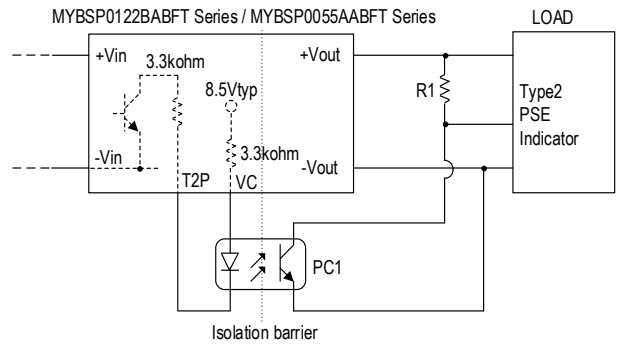

- Example
- R1: MYBSP0122BABFT Series: 33kΩ 0.1W
 - MYBSP0055AABFT Series: 15kΩ 0.1W
 - PC1: TLP293(GRH) (TOSHIBA)

| Classification | Type2 PSE Indicator |
|----------------|---------------------|
| 1-event | High |
| 2-event | Low |

Adapter ORing

DEN(Pin2) handles Enable / Disable of MYBSP0122BABFT Series / MYBSP0055AABFT Series. In case of applying external power output by adapter, MYBSP needs to be disable. Connecting DEN to -Vin disable MYBSP. There is limitation for voltage from adapter. Please see chart next page. Keep open if you don't use this function. Typical application circuit is below.

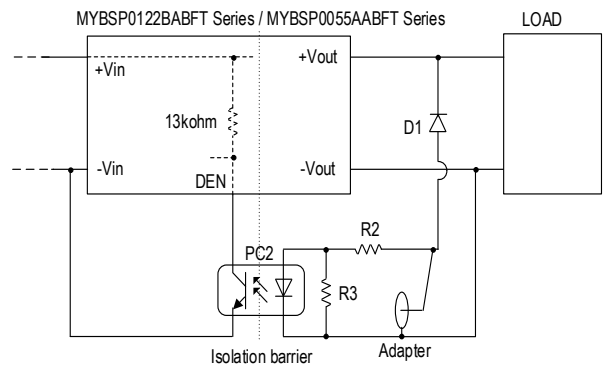

- Example
- R2: MYBSP0122BABFT Series : 1.8kΩ 0.25W
 - MYBSP0055AABFT Series : 680Ω 0.25W
 - R3: 3.3kΩ 0.1W
 - D1: RB088NS-40 (ROHM)
 - PC2: TLP293(GRH) (TOSHIBA)

Limitation for adapter voltage

| P/N | Acceptable voltage range from Adapter at Vout of MYBSP |
|-----------------------|--|
| MYBSP0122BABFT Series | 10.0 – 12.8V |
| MYBSP0055AABFT Series | 4.5 – 5.05V |

Thermal Derating Condition

The output current is limited by the derating curve. The derating curve in this datasheet illustrate typical operation under a variety of conditions.

DC-DC Converter is tested on a 101.6x188mm, 2 layers Copper evaluation board at Vin=48V.

The Unit Under Test (UUT) is set up as shown below.

UUT is covered by acrylic box to avoid airflow.

The temperature measurement points are shown below table. The temperature of measurement points should not exceed the maximum temperatures in the below table.

| Position | Description | Max temperature |
|----------|---------------------|----------------------------|
| P1 | FET | T _{P1MAX} = 124°C |
| P2 | FET | T _{P2MAX} = 124°C |
| P3 | Opto-coupler | T _{P3MAX} = 105°C |
| P4 | Transformer pattern | T _{P4MAX} = 125°C |

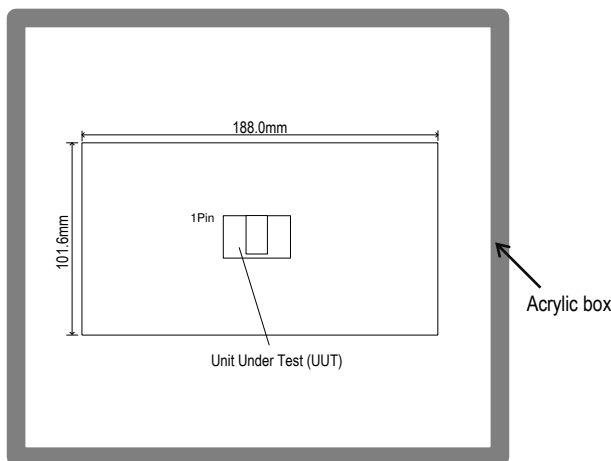
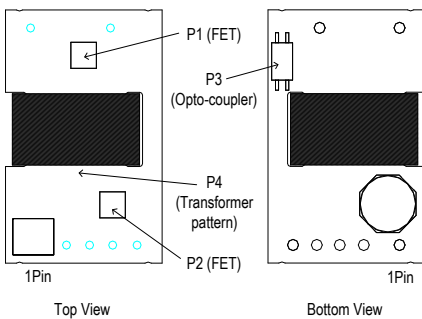

Detection and Hardware Classification

DC-DC converter implements IEEE 802.3at compliant detection and hardware classification.

When DC-DC converter(PD) is connected to PSE, the PSE applies two voltages in the range of 2.8 V to 10 V and measures the corresponding current. Connection to PD is detected by measured current.(Detection)

After Detection, the PSE applies voltage in the range of 15.5 V to 20.5 V and measures the corresponding current. PD is classified by measured current.(Hardware Classification)

Please check with your application.

SMT Reflow Soldering Guidelines

The surface-mount reflow solder profile is shown below.

This graph should be used only as a guideline.

Reflow Soldering Profiles : JEDEC IPC/JEDEC J-STD-020D

| | |
|-----------------------|-------------------------------|
| Soldering temperature | 245°C +0/-5°C |
| Soldering time | 30 seconds, 240°C-245°C |
| Heating time | 60 ~ 150 seconds, 217°C min. |
| Preheat time | 60 ~ 120 seconds, 150°C-200°C |
| Programming rate | 3°C /sec.max., 217°C-245°C |
| Descending rate | 6°C /sec.max. |
| Total soldering time | 8 minutes max., 25°C-245°C |
| Time | 1time |

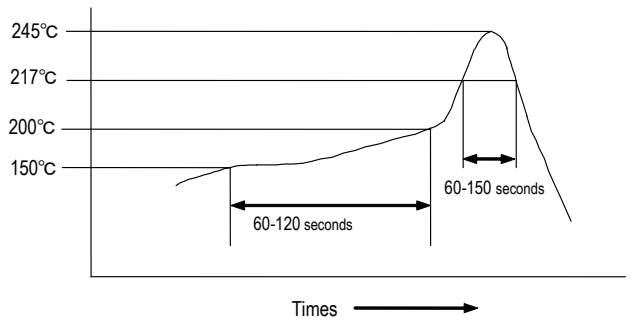

Do not vibrate for the products on reflow. Please need to take care temperature control because mounted parts may come off if the product is left under the high temperature. Do not mount on backside of the board.

Many other factors influence the success of SMT reflow soldering. Since your production environment may differ, please thoroughly review these guidelines with your process engineers.

Functional Specifications

Please contact Murata Sales before using this product for the applications listed below. These are applications that require very high reliability of prevention of defects which might directly cause damage to third party's life, body, or property.

1. Aircraft equipment
2. Aerospace equipment
3. Undersea equipment
4. Power plant control equipment
5. Medical equipment
6. Transportation equipment (cars, buses, trucks, trains, ships, etc.)
7. Traffic signal equipment
8. Disaster prevention /crime prevention equipment
9. Data-processing equipment
10. Application of similar complexity and /or reliability listed as above.

Storage

Please store this product in an environment where the temperature/humidity is stable in the range 0 to 40°C/10 to 75%RH and no direct sunlight. Use the product within 6 months after delivery.

Please avoid storage conditions where humidity and temperature change rapidly, as that may cause condensation on the product, which might degrade the quality of the product.

Please do not store the product environments that are dusty, in direct exposure to sea breeze, or in an atmosphere containing corrosive gas (Cl₂, NH₃, SO₂, NOX and so on).

Operational environment and operational conditions

This product is not chemical-proof or rust-proof.

In order to prevent this product from leakage of electricity and/or abnormal temperature increase, do not use the product under the following circumstances:

- (1) in an atmosphere containing corrosive gas (Cl₂, NH₃, SO₂, NOX and so on).
- (2) in a dusty place.
- (3) in a place exposed to direct sunlight.
- (4) in such a place where water splashes or in such a humid place where water condenses.
- (5) in a place exposed to sea breeze.
- (6) in any other places similar to the above (1)through (5).

Operational Conditions

Please use the product within specified values (power supply, temperature, input, output and load condition etc.). Input voltage drops for line impedance, so please make sure that input voltage is within in specified values.

If the product is used over the specified values, it may damage the product, reduce the quality, and even if the products can endure the condition for short time, it may cause degradation of the reliability.

Note Prior to use

If you apply high static electricity, voltage higher than rated voltage or reverse voltage to the product, it may cause defects in the products or degrade the reliability.

Please avoid the following items:

1. Over rating power supply, reverse power supply or not-enough connection of input voltage and 0V(DC)line
2. Electrostatic discharge by production line and/or operator
3. Electrified product by electrostatic induction

Do not subject product to excessive mechanical shock. If you drop the product on the floor it might cause a crack to the core of inductors and monolithic ceramic capacitors.

Also please pay attention to handling; the mounted parts can be dislodged if subjected to excessive force.

Transportation

If you transport the product, please pack it so that the package will not be damaged by mechanical vibration or mechanical shock, and please educate and guide the carrier to prevent rough handling.

Note

1. Please make sure that the product has been evaluated and confirmed against your specifications when it is mounted to your product.
2. All the items and parameters in this product specification have been prescribed on the premise that our product is used for the purpose, under the conditions and in the environment agreed upon between you and us. You are requested not to use our product deviating from such agreement.
3. We consider it not appropriate to include other terms and conditions for transaction warranty in product specifications, drawings or other technical documents. Therefore, if your technical documents as above include such terms and conditions as warranty clause, product liability clause, or intellectual property infringement liability clause, we will not be able to accept such terms and conditions unless they are based on the governmental regulation or they are stated in a separate contract agreement.



This product is subject to the following [operating requirements](#) and the [Life and Safety Critical Application Sales Policy](#):

Refer to: <https://power.murata.com/en/requirements>

Murata Manufacturing Co., Ltd makes no representation that the use of its products in the circuits described herein, or the use of other technical information contained herein, will not infringe upon existing or future patent rights. The descriptions contained herein do not imply the granting of licenses to make, use, or sell equipment constructed in accordance therewith. Spec and cautions are subject to change without notice.

© 2018 Murata Manufacturing Co., Ltd