

## OSFP-400G-FR4-C

Arista Networks® OSFP-400G-FR4 Compatible TAA 400GBase-FR4 OSFP Transceiver (SMF, 1310nm, 2km, LC, DOM, 0 to 70C)

### Features:

- Supports 425Gbps
- Up to 2km over SMF
- Duplex LC connector
- 8x53.125GBD(PAM4) electrical interface
- Data Rate 106.25Gbps optical channel
- Operating Temperature 0 to 70 Celsius
- Power dissipation < 10W
- SMF angled, polished LC simplex connector
- OSFP MSA compliant
- RoHS compliant and lead-free

### Applications:

- 4x100G FR applications
- Data Center

### Product Description

This Arista Networks® OSFP-400G-FR4 compatible OSFP transceiver provides 400GBase-FR4 throughput up to 2km over single-mode fiber (SMF) using a wavelength of 1310nm via an LC connector. It can operate at temperatures between 0 and 70C. Our transceiver is built to meet or exceed OEM specifications and is guaranteed to be 100% compatible with Arista Networks®. It has been programmed, uniquely serialized, and tested for data-traffic and application to ensure that it will initialize and perform identically. All of our transceivers comply with Multi-Source Agreement (MSA) standards to provide seamless network integration. Additional product features include Digital Optical Monitoring (DOM) support which allows access to real-time operating parameters. This transceiver is Trade Agreements Act (TAA) compliant. We stand behind the quality of our products and proudly offer a limited lifetime warranty.

ProLabs' transceivers are RoHS compliant and lead-free.

TAA refers to the Trade Agreements Act (19 U.S.C. & 2501-2581), which is intended to foster fair and open international trade. TAA requires that the U.S. Government may acquire only "U.S. – made or designated country end products."



## Regulatory Compliance

- ESD to the Electrical PINs: compatible with MIL-STD-883E Method 3015.4.
- ESD to the LC Receptacle: compatible with IEC 61000-4-3.
- EMI/EMC: compatible with FCC Part 15 Subpart B Rules, EN55022:2010.
- Laser Eye Safety: compatible with FDA 21CFR, EN60950-1& EN (IEC) 60825-1, 2.
- RoHS: compliant with EU RoHS 2.0 directive 2015/863/EU.

## Absolute Maximum Ratings

Parameter	Symbol	Min.	Typ.	Max.	Unit	Notes
Maximum Supply Voltage	Vcc	-0.5	3.3	3.6	V	
Storage Temperature	Tstg	-40		85	°C	
Operating Case Temperature	Tc	0		70	°C	1
Relative Humidity	RH	5		85	%	
Power Dissipation	P			10	W	
Electrical Signal Rate Per Channel			26.5625		Gbps	2
Optical Signal Rate Per Channel			53.125		Gbps	3
Fiber Length		2			km	4

### Notes:

1. Continuous operation at the maximum recommended operating case temperature should be avoided in order not to degrade reliability.
2. 400GAUI-8 operation with the host-generated FEC. The transmitter must receive pre-coded FEC signals from the host ASIC.
3. 400GFR8 operation with the host-generated FEC. The transmitter must receive pre-coded FEC signals from the host ASIC.
4. 9µm SMF. The maximum link distance is based on an allocation of 1dB of attenuation and 3dB total connection and splice loss. The loss of a single connection shall not exceed 0.5dB.

## Electrical Characteristics

Parameter	Symbol/Test Point	Min.	Typ.	Max.	Unit	Notes
Power Supply Voltage	Vcc	3.135	3.3	3.465	V	
Signaling Rate Per Lane	TR1		26.5625 ± 100 ppm		Gbps	
Data Input Voltage - Single-Ended		-0.5		Vcc+0.5	V	
Data Input Voltage – Differential				0.8	V	1
In-Rush Instantaneous Peak Current	I_Peak			4000	mA	
In-Rush Current (DI/Dt)	I_Inrush			100	mA/us	
Power Supply Noise				50	mVp-p	2
Receiver Differential Data Output Load		100			Ω	
Transceiver Power Consumption				10	W	
Transceiver Power Supply Total Current				3190	mA	
AC Coupling Internal Capacitor			0.1		uF	
<b>Transmitter (Per Lane)</b>						
Differential Peak-Peak Input Voltage Tolerance	TP1a	900			mV	
Differential Return Loss (Minimum)	TP1		Equation (83E-5)		dB	3
Common-Mode Differential Return Loss (Minimum)	TP1		Equation (83E-6)		dB	3
Differential Termination Mismatch	TP1		10		%	
Single-Ended Voltage Tolerance Range	TP1a	-0.4		3.3	V	
DC Common-Mode Voltage	TP1	-350		2850	mV	4
Module Stressed Input Test	TP1a		120E.3.4.1			5
Eye Width			0.22		UI	
Applied Peak-Peak Sinusoidal Jitter			Table 120E-6			3
Eye Height			32		mV	
<b>Receiver (Per Lane)</b>						
AC Common-Mode Output Voltage (Maximum, RMS)				17.5	mV	
Differential Peak-to-Peak Output Voltage Tolerance	TP4			900	mV	
Near-End ESMW (Eye Symmetry Mask Width)	TP4		0.265		UI	
Near-End Eye Height (Differential)	TP4	90			mV	
Far-End ESMW (Eye Symmetry Mask Width)	TP4		0.2		UI	
Far-End Eye Height (Differential)	TP4	30			mV	
Differential Output Return Loss (Minimum)	TP4		Equation (83E-2)		dB	6

<b>Common- to Differential-Mode Conversion Return Loss (Minimum)</b>	TP4		Equation (83e-3)		dB	6
<b>Differential Termination Mismatch</b>	TP4		10		%	
<b>Transition Time (20-80%)</b>	TP4	9.5			ps	
<b>DC Common-Mode Voltage</b>	TP4	-0.35		2.85	V	

**Notes:**

1. This is the maximum voltage that can be applied across the differential inputs without damaging the input circuitry. The damage threshold of the module input shall be at least 1600mV peak-to-peak differential.
2. Power Supply Noise is defined as the peak-to-peak noise amplitude over the frequency range at the host supply side of the recommended power supply filter with the module and recommended filter in place. Voltage levels including peak-to-peak noise are limited to the recommended operating range of the associated power supply.
3. 802.3bs.
4. DC common-mode voltage is generated by the host. Specification includes effects of ground offset voltage.
5. Module stressed input tolerance is measured using the procedure defined in 120E-3.4.1. 802.3bs.
6. 802.3bm.

## Optical Characteristics

Parameter	Symbol	Min.	Typ.	Max.	Unit	Notes
Wavelength Assignment	$\lambda C0$	1264.5	1271	1277.5	nm	
	$\lambda C1$	1284.5	1291	1297.5	nm	
	$\lambda C2$	1304.5	1311	1317.5	nm	
	$\lambda C3$	1324.5	1331	1337.5	nm	
<b>Transmitter</b>						
Side-Mode Suppression Ratio	SMSR	30			dB	
Extinction Ratio	ER	3.5			dB	
Average Launch Power		-0.3		3.7	dBm	1
OMA Per Lane		-3.3		3.5	dBm	
Launch Power in OMA Minus Transmitter and Dispersion Penalty (TDP) Per Lane		-1.7			dBm	
		-1.6				
TDECQ (PAM4)				3.1	dB	
SECQ				3.1	dB	
Rin16.5 OMA				-132	dB/Hz	
Average Launch Power Of Off Transmitter				-30	dBm	
Optical Return Loss Tolerance	17.1	dB		-30	dBm	
Transmitter Reflectance	-26	dB				
Transmitter Transition Time	17	ps				
<b>Receiver</b>						
Damage Threshold	Rxdmg	4.5			dBm	
Average Receiver Power Per Lane	Pavg	-7.3		3.5	dBm	
Receive Power (OMA) Per Lane	RxOMA			3.7	dBm	
Receiver Sensitivity (OMA) Per Lane	SenOMA			Max. (-4.6, SECQ-6)	dBm	2
Stressed Receiver Sensitivity (OMA) Per Lane	SRS			-3.1	dBm	
LOS Assert	LOSA	-30			dBm	
LOS De-Assert	LOSD			-12	dBm	
LOS Hysteresis	LOSH	0.5			dB	
RSSI Accuracy		-2		+2	dB	
Receiver Reflectance				-26	dB	

### Notes:

1. Average launch power, each lane (minimum), is informative and not the principal indicator of signal strength. A transmitter with launch power below this value cannot be compliant; however, a value above this does not ensure compliance.
2. Receiver sensitivity. @<4.6dBm for Tx with TDECQ<1.4dB; @<SECQ-6 for Tx with 3.1dB≥TDECQ≥1.4dB.

## Pin Descriptions

Pin	Logic	Symbol	Name/Description	Plug Sequence	Note
1		GND	Module Ground.	1	1
2	CML-I	Tx2+	Transmitter Data Non-Inverted.	3	
3	CML-I	Tx2-	Transmitter Data Inverted.	3	
4		GND	Module Ground.	1	1
5	CML-I	Tx4+	Transmitter Data Non-Inverted.	3	
6	CML-I	Tx4-	Transmitter Data Inverted.	3	
7		GND	Module Ground.	1	1
8	CML-I	Tx6+	Transmitter Data Non-Inverted.	3	
9	CML-I	Tx6-	Transmitter Data Inverted.	3	
10		GND	Module Ground.	1	1
11	CML-I	Tx8+	Transmitter Data Non-Inverted.	3	
12	CML-I	Tx8-	Transmitter Data Inverted.	3	
13		GND	Module Ground.	1	1
14	LVC MOS-I/O	SCL	2-Wire Serial Interface Clock.	3	2
15		Vcc	+3.3V Power Supply.	2	
16		Vcc	+3.3V Power Supply.	2	
17	Multi-Level	LPWn/PRSn	Low-Power Mode/Module Present.	3	
18		GND	Module Ground.	1	1
19	CML-O	Rx7-	Receiver Data Inverted.	3	
20	CML-O	Rx7+	Receiver Data Non-Inverted.	3	
21		GND	Module Ground.	1	1
22	CML-O	Rx5-	Receiver Data Inverted.	3	
23	CML-O	Rx5+	Receiver Data Non-Inverted.	3	
24		GND	Module Ground.	1	1
25	CML-O	Rx3-	Receiver Data Inverted.	3	
26	CML-O	Rx3+	Receiver Data Non-Inverted.	3	
27		GND	Module Ground.	1	1
28	CML-O	Rx1-	Receiver Data Inverted.	3	
29	CML-O	Rx1+	Receiver Data Non-Inverted.	3	
30		GND	Module Ground.	1	1
31		GND	Module Ground.	1	1
32	CML-O	Rx2+	Receiver Data Non-Inverted.	3	
33	CML-O	Rx2-	Receiver Data Inverted.	3	
34		GND	Module Ground.	1	1
35	CML-O	Rx4+	Receiver Data Non-Inverted.	3	

36	CML-O	Rx4-	Receiver Data Inverted.	3	
37		GND	Module Ground.	1	1
38	CML-O	Rx6+	Receiver Data Non-Inverted.	3	
39	CML-O	Rx6-	Receiver Data Inverted.	3	
40		GND	Module Ground.	1	1
41	CML-O	Rx8+	Receiver Data Non-Inverted.	3	
42	CML-O	Rx8-	Receiver Data Inverted.	3	
43		GND	Module Ground.	1	1
44	Multi-Level	INT/RSTn	Module Input/Module Reset.	3	
45		Vcc	+3.3V Power Supply.	2	
46		Vcc	+3.3V Power Supply.	2	
47	LVCMOS-I/O	SCL	2-Wire Serial Interface Data.	3	2
48		GND	Module Ground.	1	1
49	CML-I	Tx7-	Transmitter Data Inverted.	3	
50	CML-I	Tx7+	Transmitter Data Non-Inverted.	3	
51		GND	Module Ground.	1	1
52	CML-I	Tx5-	Transmitter Data Inverted.	3	
53	CML-I	Tx5+	Transmitter Data Non-Inverted.	3	
54		GND	Module Ground.	1	1
55	CML-I	Tx3-	Transmitter Data Inverted.	3	
56	CML-I	Tx3+	Transmitter Data Non-Inverted.	3	
57		GND	Module Ground.	1	1
58	CML-I	Tx1-	Transmitter Data Inverted.	3	
59	CML-I	Tx1+	Transmitter Data Non-Inverted.	3	
60		GND	Module Ground.	1	1

**Notes:**

1. OSFP uses common ground (GND) for all signals and supply (power). All are common within the OSFP module, and all module voltages are referenced to this potential unless otherwise noted.
2. Open-Drain with pull-up resistor on the host.

## Electrical Pin-Out Details

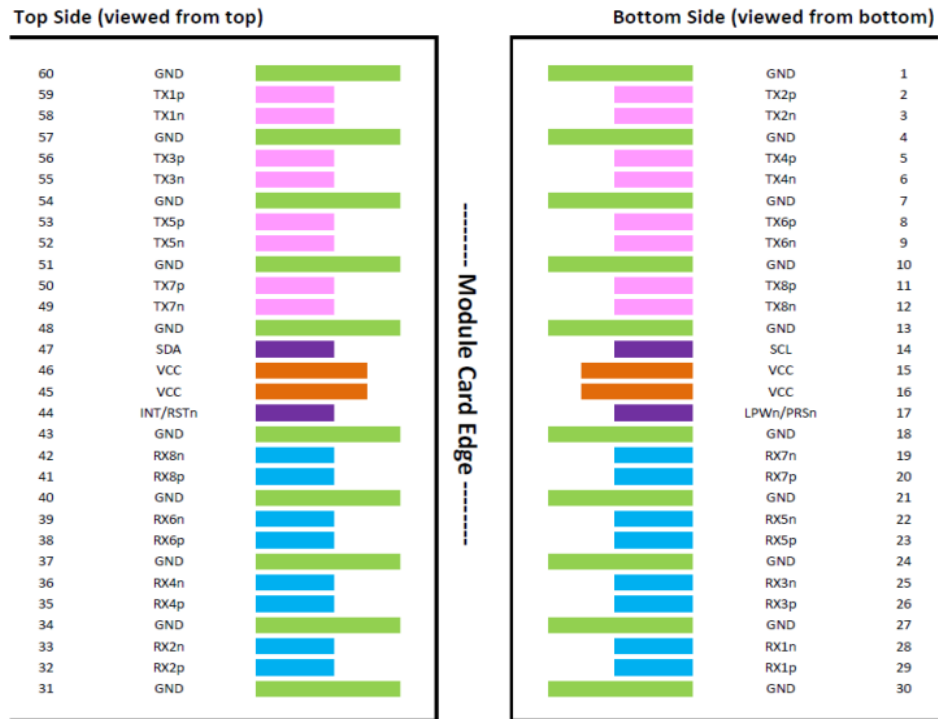

## Recommended Power Supply Filter

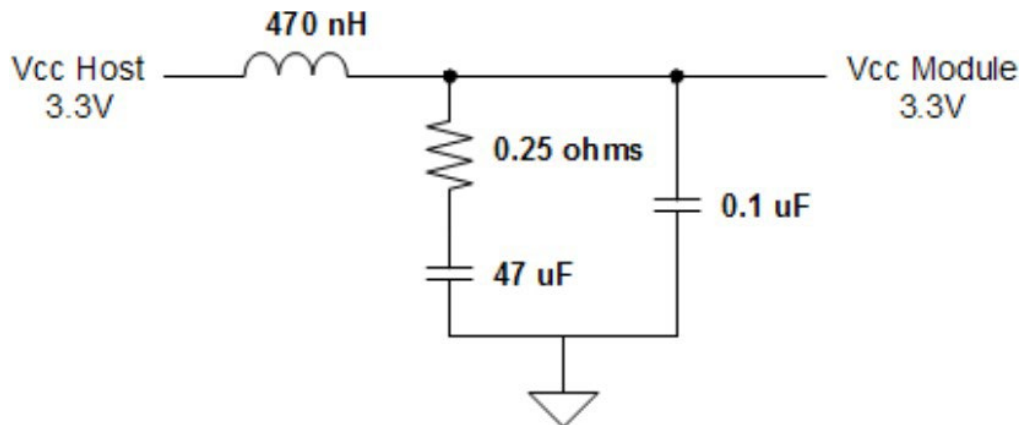



# Transceiver Block Diagram

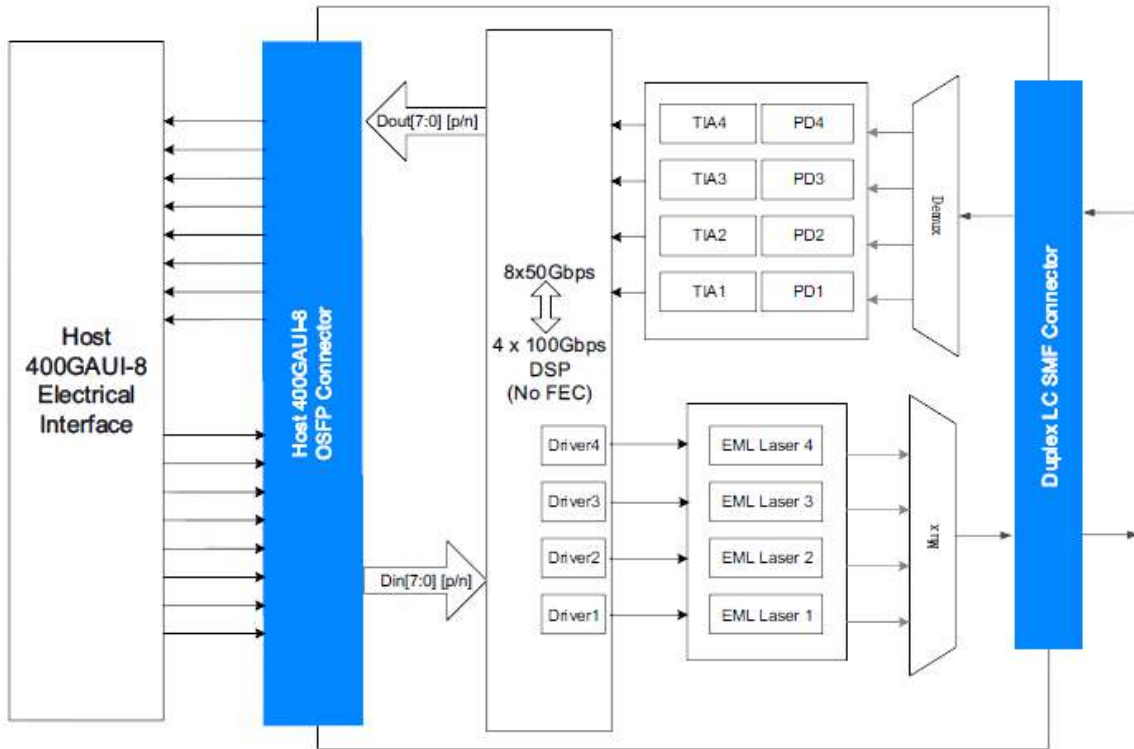
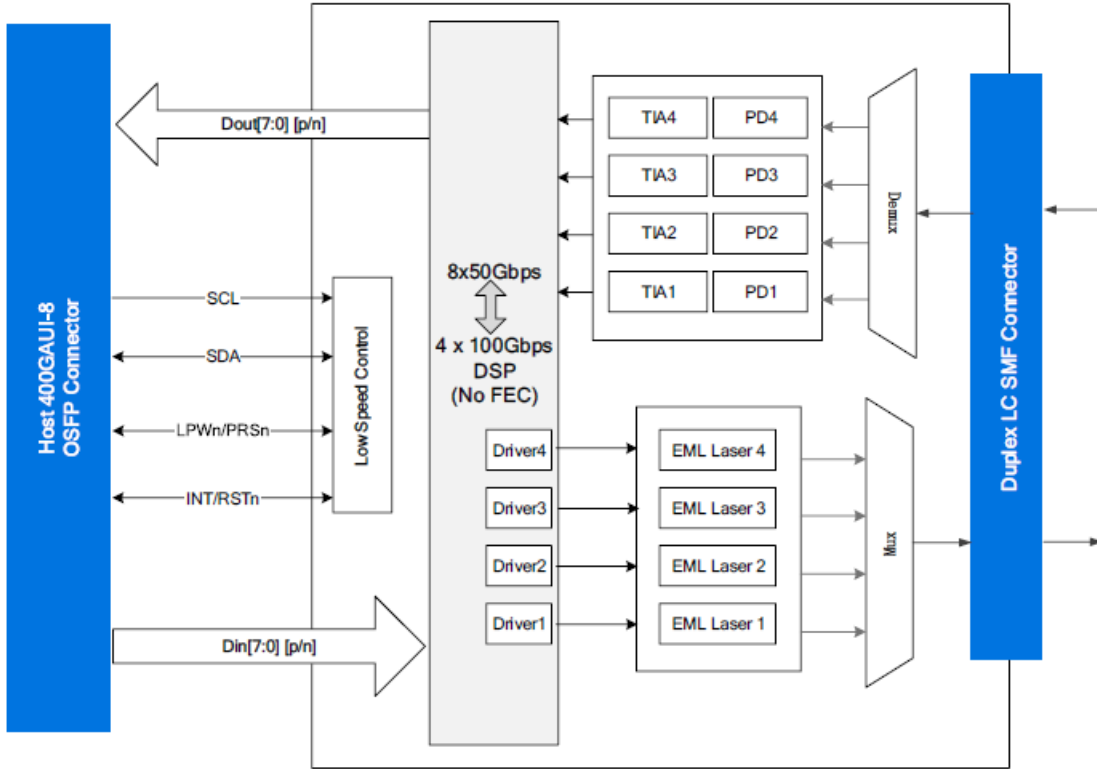

# Mechanical Specifications

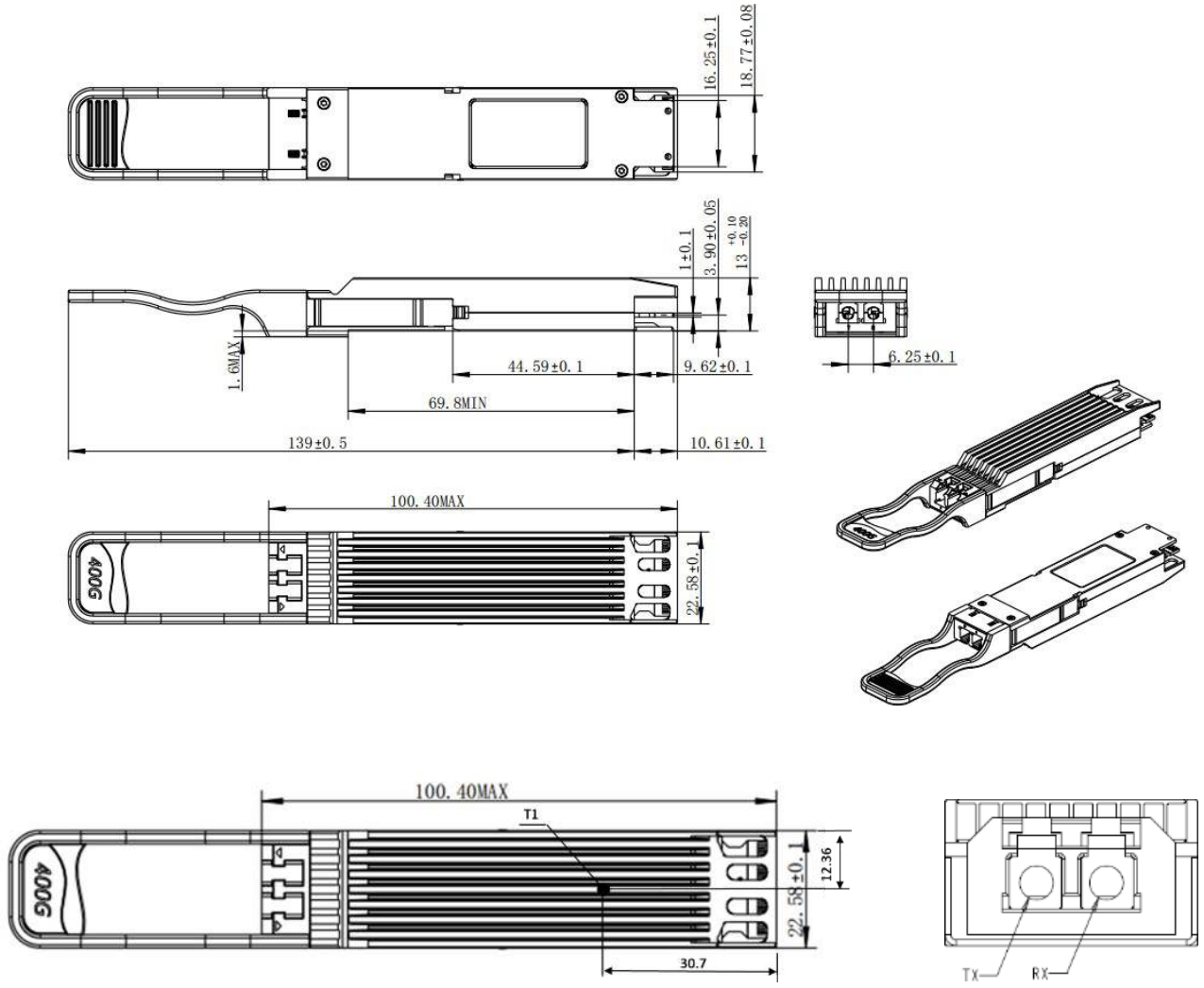

**About ProLabs**

Our experience comes as standard; for over 15 years ProLabs has delivered optical connectivity solutions that give our customers freedom and choice through our ability to provide seamless interoperability. At the heart of our company is the ability to provide state-of-the-art optical transport and connectivity solutions that are compatible with over 90 optical switching and transport platforms.

**Complete Portfolio of Network Solutions**

ProLabs is focused on innovations in optical transport and connectivity. The combination of our knowledge of optics and networking equipment enables ProLabs to be your single source for optical transport and connectivity solutions from 100Mb to 400G while providing innovative solutions that increase network efficiency. We provide the optical connectivity expertise that is compatible with and enhances your switching and transport equipment.

**Trusted Partner**

Customer service is our number one value. ProLabs has invested in people, labs and manufacturing capacity to ensure that you get immediate answers to your questions and compatible product when needed. With Engineering and Manufacturing offices in the U.K. and U.S. augmented by field offices throughout the U.S., U.K. and Asia, ProLabs is able to be our customers best advocate 24 hours a day.

**Contact Information**

ProLabs US

Email: [sales@prolabs.com](mailto:sales@prolabs.com)

Telephone: 952-852-0252

ProLabs UK

Email: [salesupport@prolabs.com](mailto:salesupport@prolabs.com)

Telephone: +44 1285 719 600