

THIS COPY IS PROVIDED ON A RESTRICTED BASIS AND IS NOT TO BE USED IN ANY WAY DETRIMENTAL TO THE INTERESTS OF PANDUIT CORP.

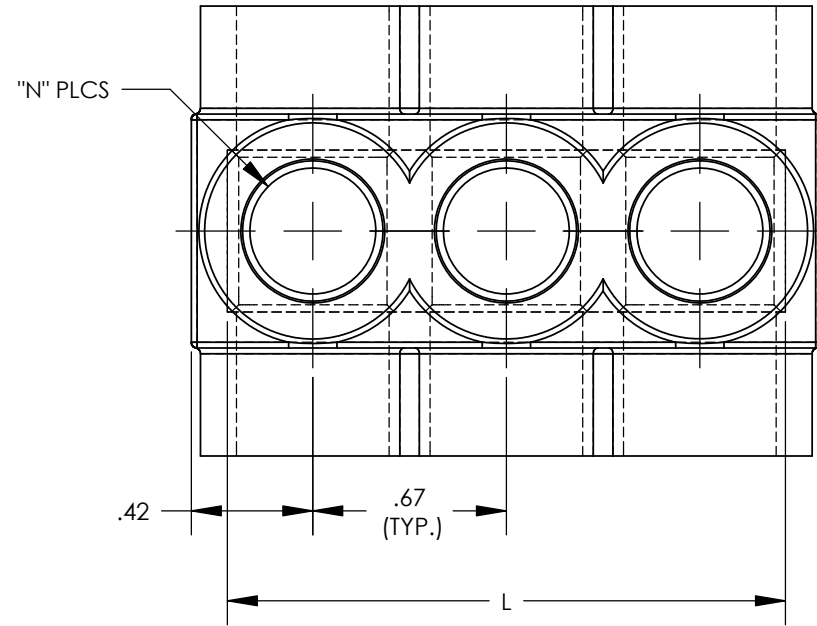

THREE PORT CONNECTOR BLOCK SHOWN WITH PLASTIC CLOSURE PLUGS REMOVED. SEE TABLE FOR DIMENSIONS OF PARTS WITH ADDITIONAL PORTS

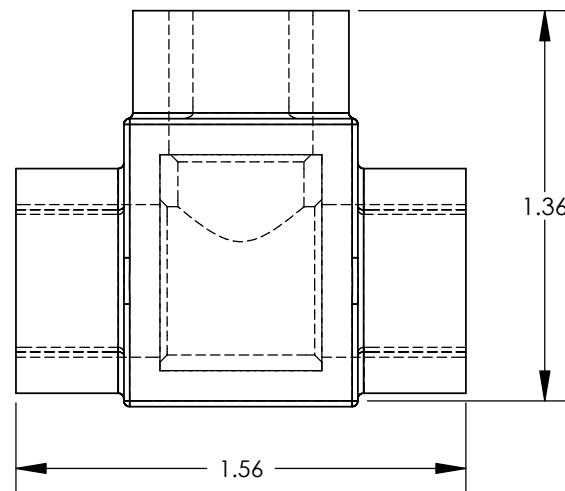
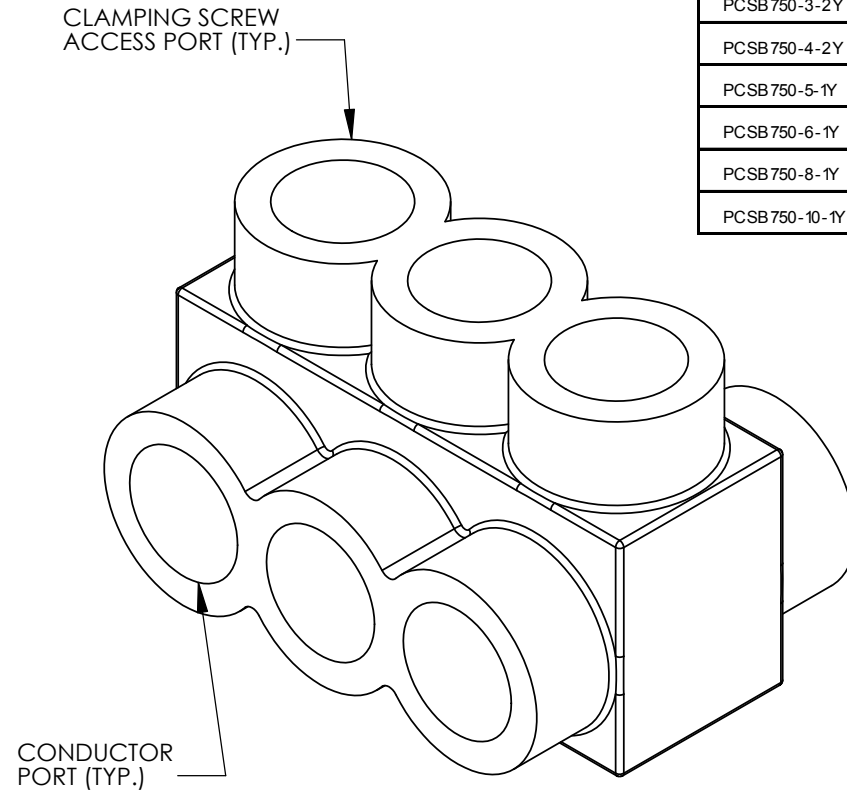
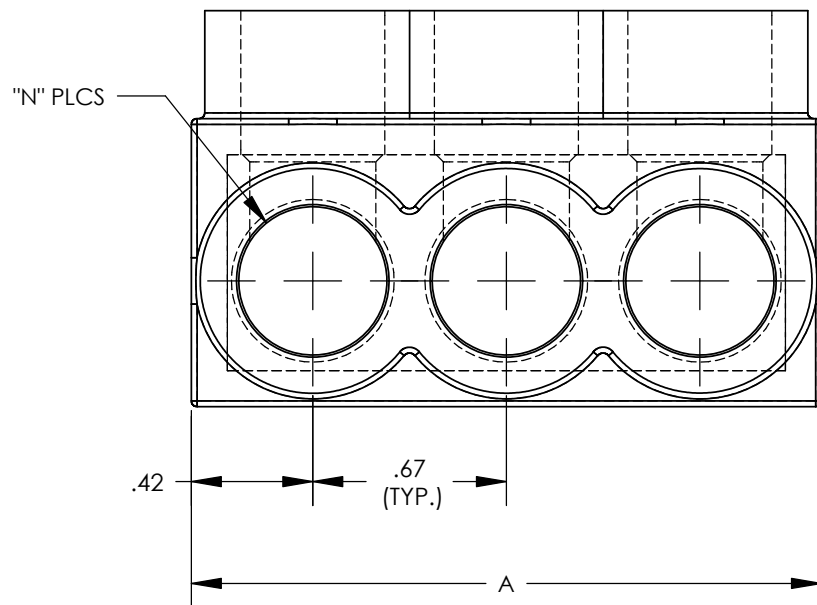

| PANDUIT FINISHED GOODS P/N | CONDUCTOR RANGE | HEX KEY | SCREW QTY. | CAP (SCREW PORT) QTY. | CAP (WIRE PORT) QTY. | A | L | N | TIGHTENING TORQUE |
|----------------------------|--------------------|---------|------------|-----------------------|----------------------|-------|---------|----|-------------------|
| PCSB750-2-2Y | 750 kcmil - #2 STR | 3/8 | 2 | 2 | 4 | 2.88 | 2.6250 | 2 | 500 in/lb |
| PCSB750-3-2Y | | 3/8 | 3 | 3 | 6 | 4.25 | 4.0000 | 3 | |
| PCSB750-4-2Y | | 3/8 | 4 | 4 | 8 | 5.63 | 5.3750 | 4 | |
| PCSB750-5-1Y | | 3/8 | 5 | 5 | 10 | 7.00 | 6.7500 | 5 | |
| PCSB750-6-1Y | | 3/8 | 6 | 6 | 12 | 8.38 | 8.1250 | 6 | |
| PCSB750-8-1Y | | 3/8 | 8 | 8 | 16 | 11.13 | 10.8750 | 8 | |
| PCSB750-10-1Y | | 3/8 | 10 | 10 | 20 | 13.88 | 13.6250 | 10 | |

NOTES:

- DUAL RATED CU9AL FOR ALUMINUM OR COPPER CONDUCTORS. MEETS OR EXCEEDS ANSI C119.4
- SEE TABLE FOR WIRE RANGE.
- STRIP LENGTH: 1.50 +.06/-0
- FOR TIGHTENING TORQUE SEE TABLE
- VOLTAGE RATING: 600 V. MAX. BUILDING WIRE, 1000 V. MAX. IN SIGNS & FIXTURES.
- TEMPERATURE RATING: 90 °C (CU9AL).
- CONNECTOR BLOCK BODY ARE MADE FROM ALUMINUM. CONDUCTOR PORTS IN CONNECTOR BLOCK ARE PREFILLED WITH AN OXIDE-INHIBITING COMPOUND.
- CONNECTOR TO INCLUDE TIN PLATED ALUMINUM CLAMPING SCREWS FOR EACH CONDUCTOR PORT.
- INSULATION MATERIAL IS CLEAR PVC.
- CLAMPING SCREW ACCESS PORTS AND ALL WIRE ENTRY PORTS ARE PROVIDED WITH REMOVABLE PLASTIC CLOSURE PLUGS.
- ALL DIMENSIONS SHOWN ARE NOMINAL.
- ONLY ONE CONDUCTOR PER PORT ALLOWED.
- PACKAGE QTY: -12 = 12 PCS.
-6 = 6 PCS.
-4 = 4 PCS.
- THIS PART IS RoHS COMPLIANT.

| | | | | | | | | | | | | | | |
|--|--|--|--|--|--|--|--|--|--|---|---------------|--|-------------|--|
| | | | | | | | | | | | | | | |
| | | | | | | | | | | | | MULTI-TAP INSULATED CONNECTORS PCSB750 SERIES | | |
| | | | | | | | | | | UNLESS OTHERWISE SPECIFIED DIMENSIONAL TOLERANCES ARE: (.X) ± (.XXX) ± (.XX) ± ANGLES ± | | | | UNLESS OTHERWISE SPECIFIED, ALL DIMENSIONS ARE GIVEN IN INCHES, THIRD ANGLE PROJECTION |
| | | | | | | | | | | | | | | |
| | | | | | | | | | | | | | | |
| | | | | | | | | | | REV 03 | DATE 11/09 | BY JHNU | CHK JHNU | DESCRIPTION REVISED NOTE 3: 1.50 WAS .56 ADDED HEX KEY SIZE TO TABLE |