

- 1 POST TO WITHSTAND 13 NEWTONS (3 LBS) MINIMUM AXIAL FORCE IN BOTH DIRECTIONS SHOWN WITHOUT DISLODGING.
- 2 TOLERANCES APPLY TO SOLDER SIDE OF BOARD.
- 3 MEASURED AT -A-
- 4 PLASTIC FLASH PERMITTED IN THIS AREA.
- 5 PARTS COMPLY WITH AMP SOLDERABILITY SPEC. NO. 109-11-2.
- 6 ONE HOLE MAY BE UNDERSIZED 0.81-0.89 [.032-.035] DIA. FOR ASSEMBLY RETENTION DURING WAVE SOLDERING.
- 7 MATERIAL: HEADER-THERMOPLASTIC POLYESTER  
94V-0 (NATURAL)  
POST-COPPER ALLOY  
FINISH-USE PLATING NOTES 13 & 14 FOR -2 THRU -28 AND NOTES 13 & 15 FOR -32 THRU -58
- 8 COORDINATE DIMENSION APPLIES FROM CENTER OF ACTUAL FEATURE.
- 9 PLASTIC BURRS CAUSED BY CUT-OFF TOOLING ARE PERMITTED WITHIN THE MAXIMUM TOLERANCE ENVELOPE.
- 10 POSTS TO BE MEASURED WHEN STRIP IS HELD FLAT.
- 11 POST MUST WITHSTAND TWO 90° BENDS AGAINST EXTRUSION WITHOUT BREAKING.
- 12 DIMENSION SHOULD BE 3.30 [.130] WHEN MATING WITH A MTA-100 CONNECTOR ASSEMBLY OR A CST-100 CONNECTOR ASSEMBLY.
- 13 PLATING: GOLD PLATE AREA, 0.00076 [.000030] GOLD OR 0.00008 [.000003] MIN GOLD FLASH OVER 0.00068 [.000027] PALLADIUM NICKEL, PER TE CONNECTIVITY'S DISCRETION, ALL SIDES, OVER NICKEL UNDERPLATE, .00127 [.000050] MIN, ALL SIDES AND ENTIRE LENGTH OF POST.
- 14 PLATING: MATTE TIN PLATE AREA, 0.00381-0.00889 [.000150-.000350] THICK, ALL FOUR SIDES 3.56 [.140] MINIMUM.
- 15 PLATING: MATTE TIN PLATE AREA, 0.00381-0.00889 [.000150-.000350] THICK, ALL FOUR SIDES 3.56 [.140] MINIMUM.
- 16 OBSOLETE PARTS: OBSOLETE CIS STREAMLINING PER D.RENAUD/D.SINISI

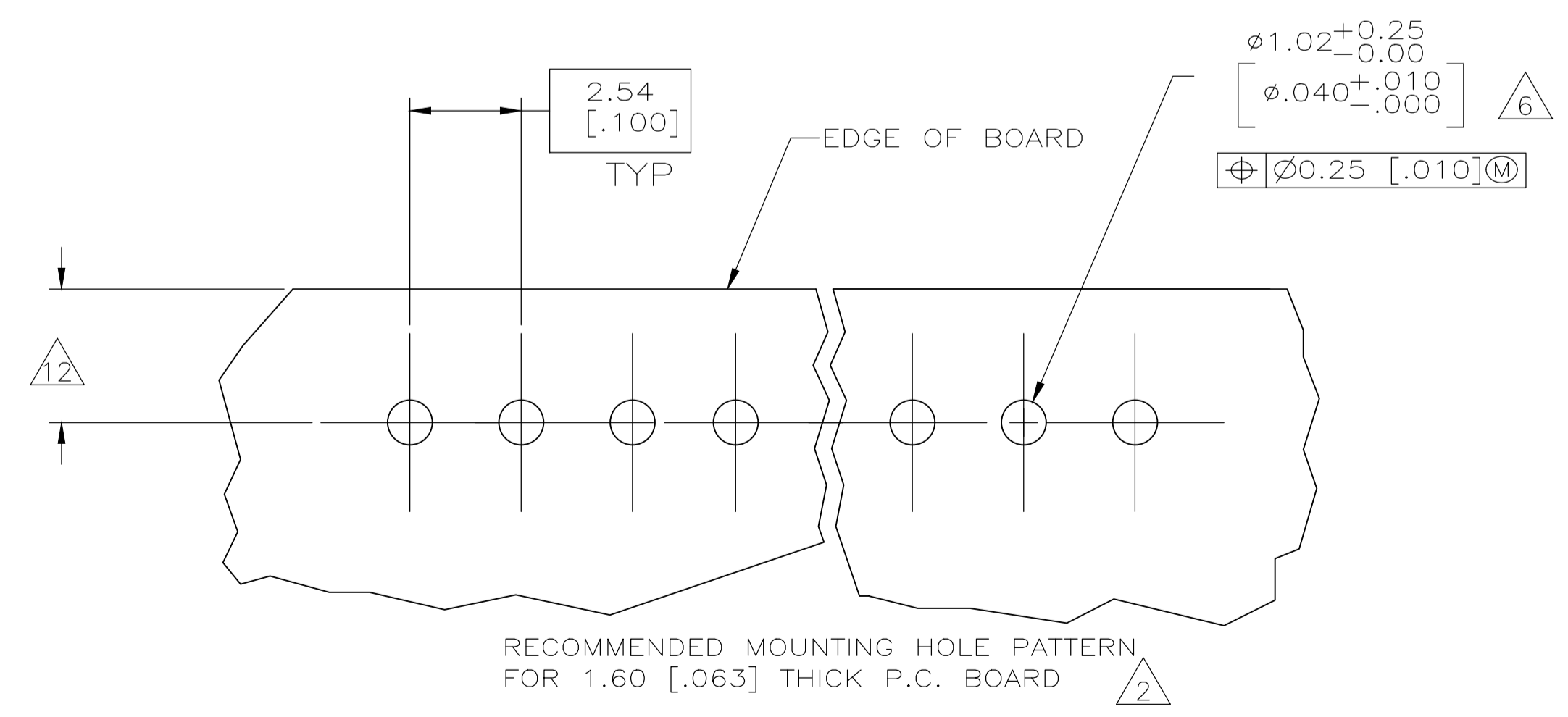

71.12 [2.800]	28	5-641213-8
68.58 [2.700]	27	5-641213-7
66.04 [2.600]	26	5-641213-6
63.50 [2.500]	25	5-641213-5
60.96 [2.400]	24	5-641213-4
58.42 [2.300]	23	5-641213-3
55.88 [2.200]	22	5-641213-2
53.34 [2.100]	21	5-641213-1
50.80 [2.000]	20	5-641213-0
48.26 [1.900]	19	4-641213-9
45.72 [1.800]	18	4-641213-8
43.18 [1.700]	17	4-641213-7
40.64 [1.600]	16	4-641213-6
38.10 [1.500]	15	4-641213-5
35.56 [1.400]	14	4-641213-4
33.02 [1.300]	13	4-641213-3
30.48 [1.200]	12	4-641213-2
27.94 [1.100]	11	4-641213-1
25.40 [1.000]	10	4-641213-0
22.86 [.900]	9	3-641213-9
20.32 [.800]	8	3-641213-8
17.78 [.700]	7	3-641213-7
15.24 [.600]	6	3-641213-6
12.70 [.500]	5	3-641213-5
10.16 [.400]	4	3-641213-4
7.62 [.300]	3	3-641213-3
5.08 [.200]	2	3-641213-2
DIM (L)	NO. OF POSN	ASSEMBLY

71.12 [2.800]	28	2-641213-8
68.58 [2.700]	27	2-641213-7
66.04 [2.600]	26	2-641213-6
63.50 [2.500]	25	2-641213-5
60.96 [2.400]	24	2-641213-4
58.42 [2.300]	23	2-641213-3
55.88 [2.200]	22	2-641213-2
53.34 [2.100]	21	2-641213-1
50.80 [2.000]	20	2-641213-0
48.26 [1.900]	19	1-641213-9
45.72 [1.800]	18	1-641213-8
43.18 [1.700]	17	1-641213-7
40.64 [1.600]	16	1-641213-6
38.10 [1.500]	15	1-641213-5
35.56 [1.400]	14	1-641213-4
33.02 [1.300]	13	1-641213-3
30.48 [1.200]	12	1-641213-2
27.94 [1.100]	11	1-641213-1
25.40 [1.000]	10	1-641213-0
22.86 [.900]	9	641213-9
20.32 [.800]	8	641213-8
17.78 [.700]	7	641213-7
15.24 [.600]	6	641213-6
12.70 [.500]	5	641213-5
10.16 [.400]	4	641213-4
7.62 [.300]	3	641213-3
5.08 [.200]	2	641213-2
DIM (L)	NO. OF POSN	ASSEMBLY



THIS DRAWING IS A CONTROLLED DOCUMENT.

DIN S. HOOVER 26-JAN-2005

CHK: D. ROSSI 26-JAN-2005

APVD: D. ROSSI 26-JAN-2005

NAME: MTA-100 HEADER ASSEMBLY, POLARIZED, NOTCHED, .025 SQUARE STRAIGHT POST, .000030 GOLD PLATED

PRODUCT SPEC

APPLICATION SPEC

SIZE: A1

CAGE CODE: 641213

DRAWING NO: 641213

WEIGHT

CUSTOMER DRAWING

SCALE: 8:1

SHEET: 1 of 1

REV: Y1