

SYM	REVISION DESCRIPTION	DFTM	DATE	APPD	APPD
A	RELEASED FOR PRODUCTION	Monica.W	2018.06.04	Joslen.W	2018.06.04

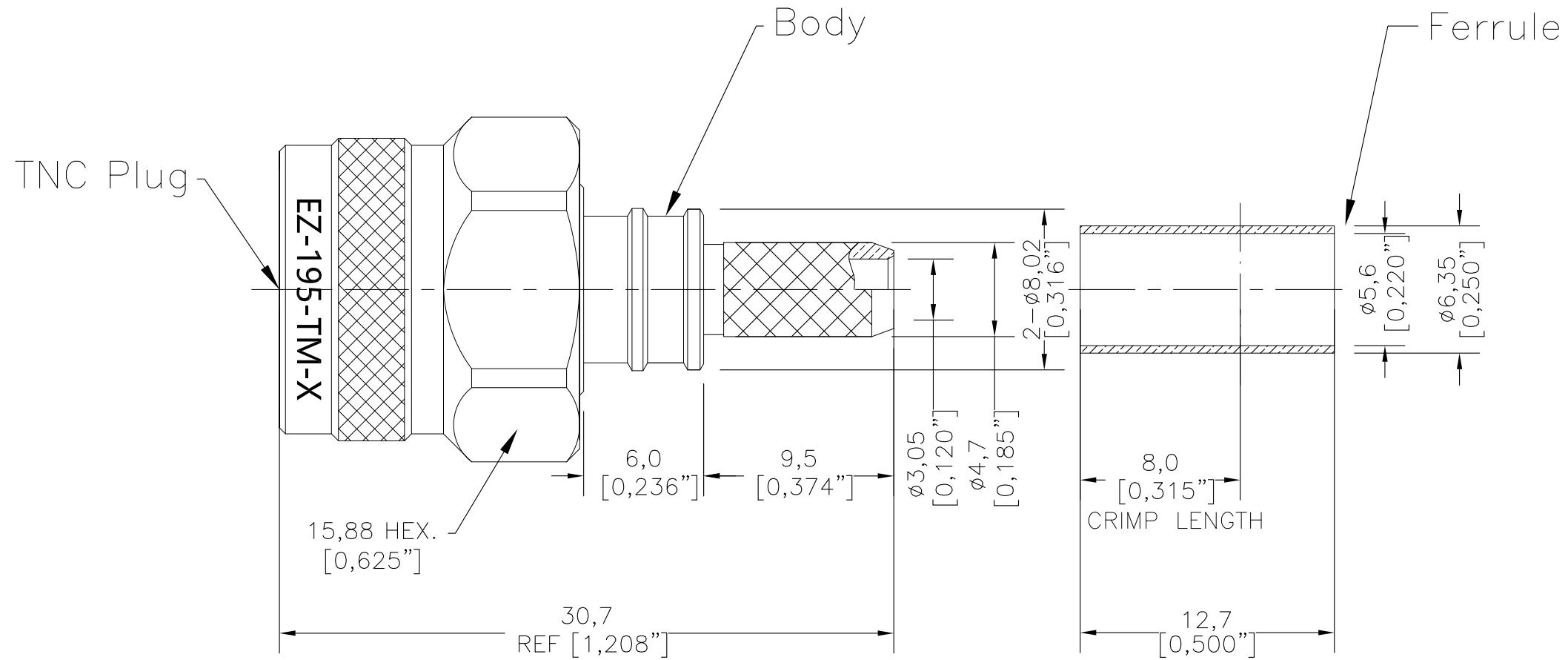

I. MATERIALS & FINISHES

Components	Materials	Finishes	Thk. (μ")
Body	Brass	Albaloy	80
Center Cont.	Beryllium Copper	Gold	50
Ferrule	Brass	Albaloy	80
Nut	Brass	Albaloy	80
Insulator	PTFE	--	--
Gasket	Silicone	--	--

II. ELECTRICAL PROPERTIES

Impedance (Ω):	50
Frequency Range (GHz):	DC to 6 GHz
Dielectric Withstanding Voltage (V):	1000
Insulation Resistance (MΩ):	≥5000
VSWR:	≤1.30
Insertion Loss(dB, f/GHz):	-0.1x √f

III. ENVIRONMENT PROPERTIES

Temperature Range:	-40°C~+125°C
Thermal Shock:	MIL-STD 202G, Meth.107, Cond.B
Vibration:	MIL-STD 202G, Meth.204, Cond.B
Shock:	MIL-STD 202G, Meth.213, Cond I
Climatic Class:	IEC 60068 65/165/21
(2002/95/EC)RoHS:	Compliant

IV. MECHANICAL PROPERTIES

Center Cont.:	Finger Contact
Outer Cont.:	Crimp
Coupling Nut Torque (N.m):	N/A
Cbl-Connector Retention Force (N):	177
Durability (cycles):	500

V. TOOLING

Stripping Tool: 3192-102/CST-195/200
 Crimping Tool: 3190-667/CT-240/200/100

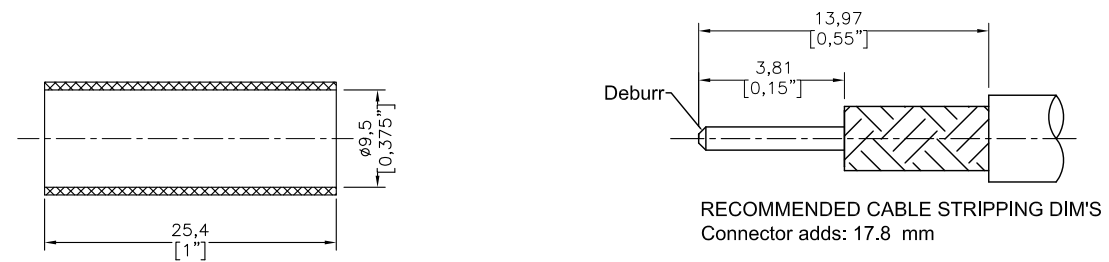

Shrink Tube (3/8"x1" 3:1)

Compatible with Standard: IEC 60169-17

MATL:	UNLESS OTHERWISE SPECIFIED	DFTM. Monica.W	
USED ON: O	ALL DIMENSIONS ARE IN mm MACHINED SURFACES FINISH 1.6 RMS MAX. REMOVE ALL BURRS 0.15X45° MAX. BREAK MACHINE CORNERS 0.15X45° D MAX. FILLET R. TOLERANCES ON DECIMALS .X ±0.3 .XX ±0.15 ANGLES ±2° FRACTIONS ± N/A	DATE 2018.06.04	
SCALE: N/A		CHKD Patrick.M	
DWG SIZE A4		DATE 2018.06.04	
DO NOT SCALE DRAWING	CODE IDENT 68999	APPD Joslen.W	EZ-195-TM-X TNC Male (Plug) Straight Non- Solder Pin No Braid Trim Connector for LMR-195 Cable
		DATE 2018.06.04	