

CUSTOMER DRAWING

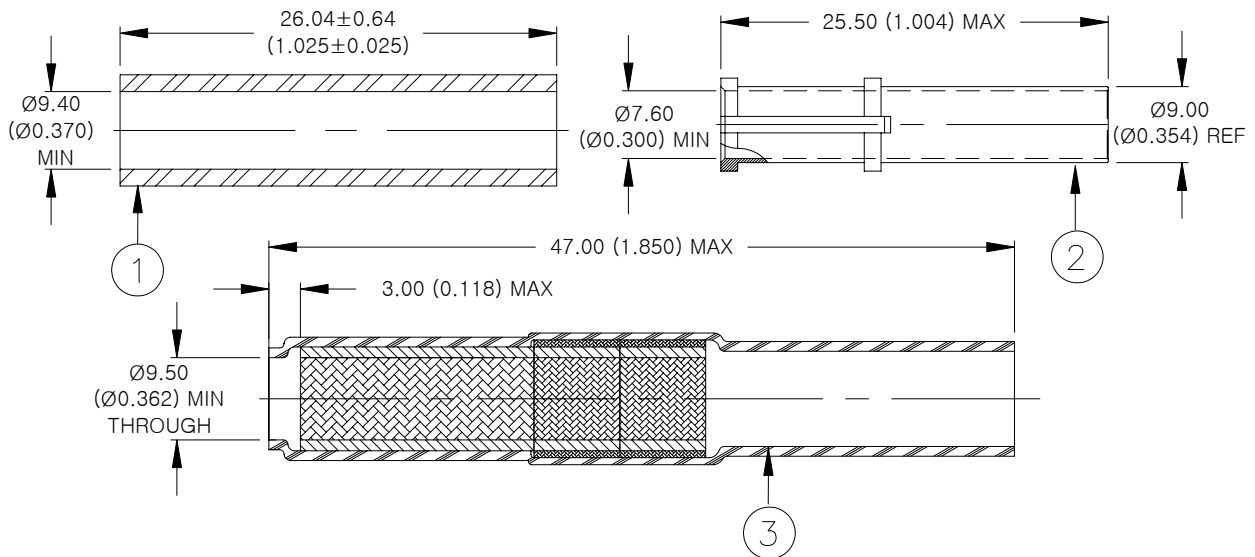

MATERIALS

1. INSULATION SLEEVE: Heat-shrinkable, transparent blue, radiation cross-linked modified polyvinylidene fluoride.
2. FERRULE: Copper alloy with a suitable plating (see below for plating information).
3. SOLDERSHIELD Device:
 - INSULATION SLEEVE: Heat-shrinkable, transparent blue, radiation cross-linked modified polyvinylidene fluoride.
 - SHIELD: Solder impregnated, flux coated copper.
 - SOLDER: TYPE Sn96 per ANSI / J-STD-006.
 - FLUX: TYPE ROM1 per ANSI / J-STD-004.

APPLICATION

1. These parts are used on Tyco Electronics / Raychem Hexashield adaptors HXS103-AY-00-14-A1-1, HXS120-AY-90-17-A1-1, HXS121-AY-90-21-A1-1 and HYS113-AY-00-21-A4-1
2. Cable Type: Single or multi-conductors shielded cable: Raychem Spec 44 or Spec 55, single braid. (tin, silver or nickel-plated copper braid)
3. Temperature range: -65°C to +175°C.
4. For all other applications, contact Tyco Electronics / Raychem technical service.

Part Numbering:

HET-A-05X



Ferrule Plating:

- B: Olive drab cadmium in accordance with SAE AMS-QQ-P-416, over a suitable underplate to withstand 500 hours of salt spray test.
- C: Electroless nickel conforming to SAE AMS-C-26074 Class 3, Grade B.

Cable Accommodation and Preparation:

Cable dimensions:

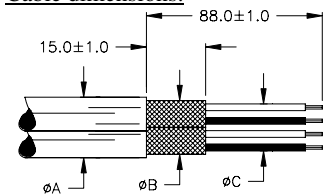

Maximum quantity of braids: 4

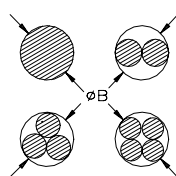

Dimensions				
øA		øB		øC
Min.	Max.	Min.	Max.	Max.
5.00 (0.197)	11.80 (0.465)	4.00 (0.157)	11.80 (0.465)	7.50 (0.295)

Installation:

Refer to Tyco Electronics / Raychem installation procedure RPIP-696-00 for assembly instructions, inspection and repair.

		300 Constitution Dr Menlo Park, CA 94025, U.S.A.	TITLE: FERRULE AND SOLDERSHIELD DEVICE FOR HEXASHIELD ADAPTORS		
Unless otherwise specified dimensions are in millimeters. [Inches dimensions are shown in brackets]		Raychem Devices	DOCUMENT NO.: HET-A-05X		
TOLERANCES: 0.00 N/A 0.0 N/A 0 N/A	ANGLES: N/A ROUGHNESS IN MICRON	Tyco Electronics reserves the right to amend this drawing at any time. Users should evaluate the suitability of the product for their application.		REV: C	DATE: November 2, 2009
REVISED BY: UNGUYEN	CAGE CODE: 06090	ECO NUMBER: ECO-09-024439	SCALE: NTS	SIZE: A	SHEET: 1 of 1

© 2004-2009 Tyco Electronics Corporation. All rights reserved.

If this document is printed it becomes uncontrolled. Check for the latest revision.