



MADE
IN THE **USA**
PATENT PENDING

Product Description:

- Protection Dispenser - Universal Boxed - Large
- Dispenses Shoe Covers/Caps/Other
- Holds a variety of oversized boxes of bouffant caps, surgeons' caps, and shoe-covers from most major manufacturers
- Keyholes for wall mounting
- Made of Quartz Beige ABS Plastic

Primary Area for Product Usage:

- Patient care areas: OR dressing rooms, surgery centers, labs, interventional radiology, ICU, clinics

Dispenses:

Most oversized boxes of protection apparel:

- Boxes no larger than 12.25"W x 20.00"H x 9.63"D (31.1 cm x 50.8 cm x 24.5 cm)
- Boxes no smaller than 9.00"W x 8.00"H x 7.50"D (22.9 cm x 20.3 cm x 19.1 cm)

Package Specifications:

- Package Quantity: 2 per case
- 16"L x 12"W x 12"H (40.6 cm x 30.5 cm x 30.5 cm)
- 5.0 lbs (2.3 kg) - approximated

Product Specifications (overall external dimensions):

- 12.50"W x 10.13"H x 9.88"D (31.8 cm x 25.7 cm x 25.1 cm)
- 1.9 lbs (0.8 kg) - approximated

Mounting Specifications:

Alternative Products (each sold separately):

- PD100-0212, Protection Dispenser - Universal Boxed
- PD300-0212, Protection Dispenser - Universal Boxed



PD100-0212

PD300-0212

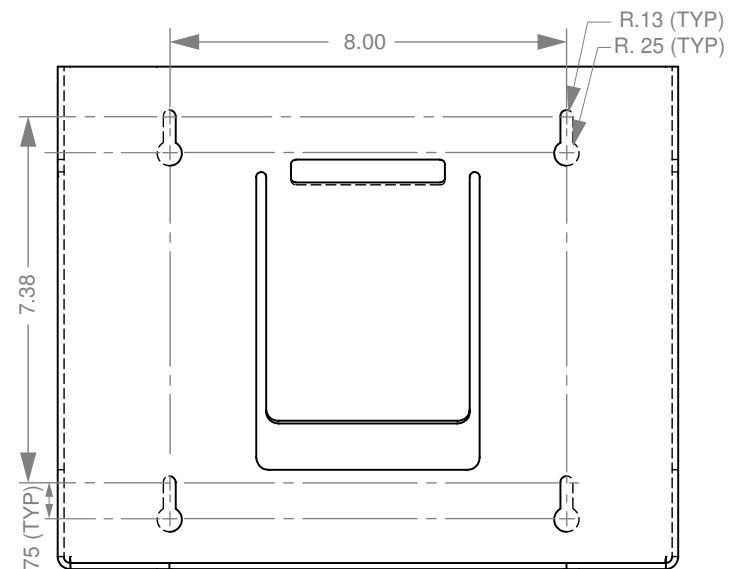



Installation

Always mount dispensers securely *prior* to loading with product.

- Spring design provides secure fit for a wide assortment of boxed products.
- Open configuration allows dispensing of product through top or front.

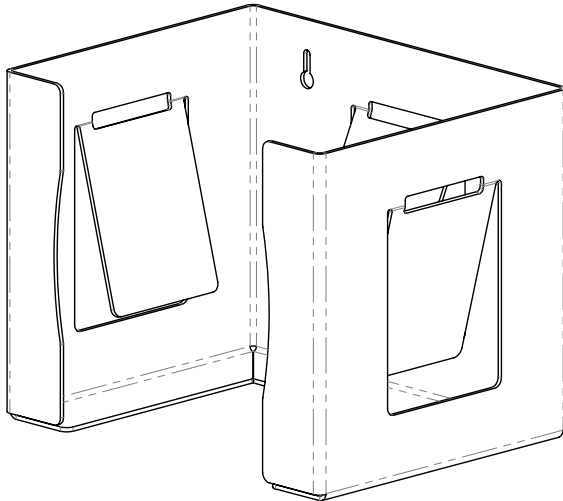

- Mount securely to a wall with screws approved and supplied by building maintenance.

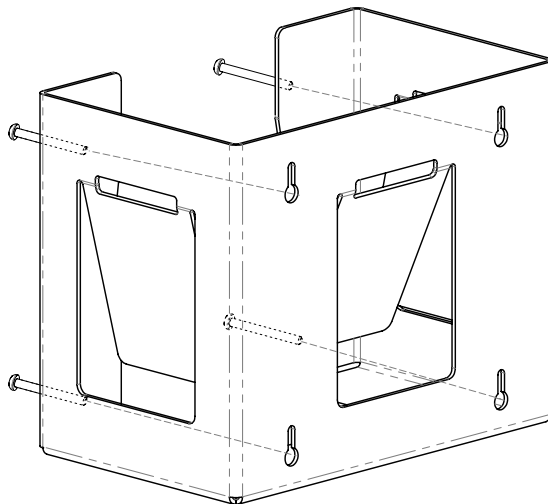

Parts included:

- Dispenser

Tools Required:

- No tools required to assemble dispenser

Care and Construction

ABS Plastic

Material Characteristics

Designed for Long-Term, Heavy-Duty Applications

The combination of copolymers (Acrylonitrile, Butadiene, and Styrene) gives ABS an excellent combination of strength, rigidity, and toughness.

ABS is chemical, stress-crack resistant, dimensionally stable, and will hold up to long-term use. It possesses high strength and performance characteristics at a reasonable cost.

Care and Cleaning

Use mild soap and water to clean. Petroleum-based oils, solvents, and paints should not be used.

Standard hospital cleaning supplies are approved for use on our ABS plastic products.