

DO NOT SCALE FROM THIS PRINT

QTS-XXX-XX-XXX-D-RA-XX-XXX

No OF POSITIONS  
 -025, -050, -075, \*-100  
 [PER ROW]  
 \* = SEE NOTE 14

LEAD STYLE  
 -01: .062 [1.57] BOARD  
 -02: .093 [2.36] BOARD

PLATING SPECIFICATION  
 (SEE TABLE 4, SHT 4)

ROW SPECIFICATION  
 -D: DOUBLE (USE QTS-25-01-D-XX-RA)

OPTION  
 -LS1: LOCKING SCREW  
 (FOR MATING WITH QSS...-RA...-LS1)  
 (USE WITH SP-18-01-TM SOLDER PIN)  
 (SEE NOTE 11 & FIG 2, SHT 5)

-LS2: LOCKING SCREW  
 (FOR MATING WITH QSS...-LS2)  
 (USE WITH SP-18-01-TM SOLDER PIN)  
 (SEE NOTE 11 & FIG 3, SHT 5)

-P: PICK AND PLACE PAD  
 (USE PPP-63, SEE FIG 4, SHT 5)

-SP: SOLDER PIN  
 (NOT AVAILABLE W/ LSX OPTIONS)  
 (USE SP-19-T, SEE FIG 5, SHT 5)

OPTION  
 -WT: WELD TAB  
 (SEE NOTE 5, USE WT-16-XX-T)

-RA: RIGHT ANGLE

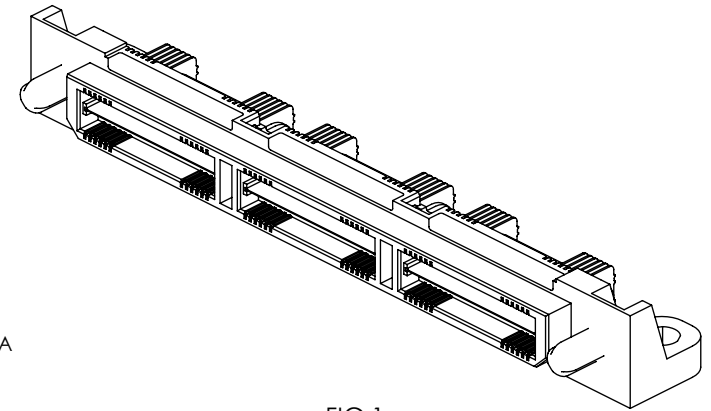
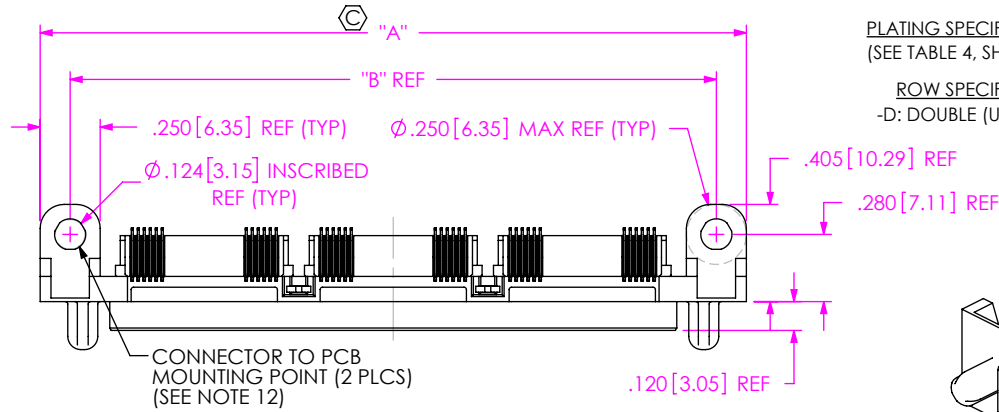

FIG 1  
 QTS-075-01-XXX-D-RA-WT SHOWN  
 (SOME CENTER DETAIL REMOVED FOR CLARITY)

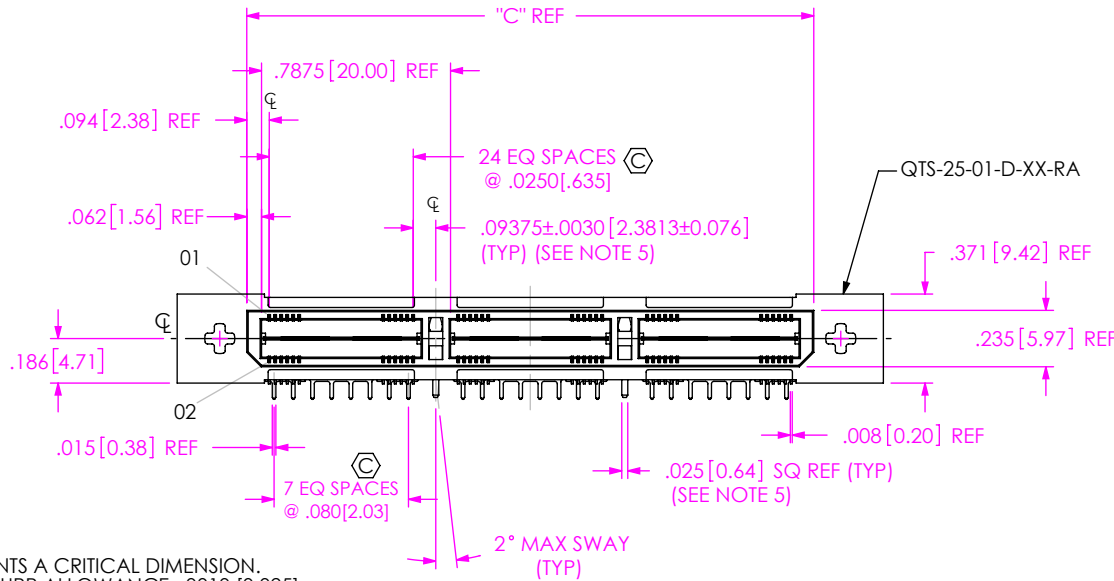

TABLE 1

| POSITION | "A"           | "B"           | "C"           | "D"           |
|----------|---------------|---------------|---------------|---------------|
| -025     | 1.368 [34.73] | 1.118 [28.38] | 0.788 [20.00] | 0.396 [10.06] |
| -050     | 2.155 [54.74] | 1.905 [48.39] | 1.575 [40.01] | 0.790 [20.07] |
| -075     | 2.943 [74.74] | 2.693 [68.39] | 2.363 [60.01] | 1.184 [30.07] |
| *-100    | 3.730 [94.74] | 3.480 [88.39] | 3.150 [80.01] | 1.578 [40.07] |

\* = SEE NOTE 14

NOTES:

1. Ⓢ REPRESENTS A CRITICAL DIMENSION.
2. MAXIMUM BURR ALLOWANCE: .0010 [0.025] .
3. MINIMUM PUSHOUT FORCE: 5 OZ.
4. NOTE DELETED.
5. -WT OPTION MUST BE SELECTED FOR -050, -075 & -100 POSITIONS.
6. TIPS OF TERMINALS MAY NOT EXTEND BEYOND THIS SURFACE.
7. IF NEEDED, -L PLATING CAN BE SUBSTITUTED FOR -F PLATING.
8. DESIGNED FOR USE WITH A .062 [1.57] OR .093 [2.36] THICK PCB.
9. PACKAGE IN TRAYS AS STANDARD.
10. NOTE DELETED.
11. MAXIMUM TORQUE ON STS-02 TO BE 20 IN-OZ.
12. TORQUE TO BE 10.0 IN-OZ USING 4-40 UNC SCREW.
13. USE -Z- DATUM ZONE ONLY FOR MEASUREMENTS.
14. AVAILABLE FOR EXISTING CUSTOMERS ONLY.

UNLESS OTHERWISE SPECIFIED, DIMENSIONS ARE IN INCHES.

TOLERANCES ARE:

DECIMALS ANGLES  
 .XX: ±.01 [0.3] 2°  
 .XXX: ±.005 [0.13]  
 .XXXX: ±.0020 [0.051]

PROPRIETARY NOTE

THIS DOCUMENT CONTAINS CONFIDENTIAL AND PROPRIETARY INFORMATION AND ALL DESIGN, MANUFACTURING, REPRODUCTION, USE, PATENT RIGHTS AND SALES RIGHTS ARE EXPRESSLY RESERVED BY SAMTEC, INC. THIS DOCUMENT SHALL NOT BE DISCLOSED, IN WHOLE OR PART, TO ANY UNAUTHORIZED PERSON OR ENTITY NOR REPRODUCED, TRANSFERRED OR INCORPORATED IN ANY OTHER PROJECT IN ANY MANNER WITHOUT THE EXPRESS WRITTEN CONSENT OF SAMTEC, INC.

MATERIAL: DO NOT SCALE DRAWING  
 INSULATOR: LCP, COLOR: BLACK  
 TERMINAL, WELD TAB & GROUND PLANE: PHOS BRONZE  
 SCREW: STEEL

SHEET SCALE: 1:0.8

DESCRIPTION:  
 .635mm DOUBLE ROW RIGHT ANGLE TERMINAL STRIP

DWG. NO.  
 QTS-XXX-XX-XXX-D-RA-XX-XXX

BY: KEVIN B 08/03/01 SHEET 1 OF 5



520 PARK EAST BLVD, NEW ALBANY, IN 47150  
 PHONE: 812-944-6733 FAX: 812-948-5047  
 e-Mail info@SAMTEC.com code 55322

| TABLE 2    |            |            |                  |            |
|------------|------------|------------|------------------|------------|
| LEAD STYLE | "E"        | "F"        | IM-1G14-XX-1-XXX | WT-16-XX-T |
| -01        | .060[1.52] | .068[1.73] | IM-1G14-01-1-XXX | WT-16-01-T |
| -02        | .125[3.18] | .125[3.18] | IM-1G14-02-1-XXX | WT-16-03-T |

| TABLE 3         |             |                    |                    |
|-----------------|-------------|--------------------|--------------------|
| NO OF POSITIONS | COPLANARITY | STRAIGHTNESS ROW 1 | STRAIGHTNESS ROW 2 |
| -025 THRU -075  | .004[.10]   | .004[.10]          | .004[.10]          |
| *-100           | .006[.15]   | .006[.15]          | .006[.15]          |

\* = SEE NOTE 14

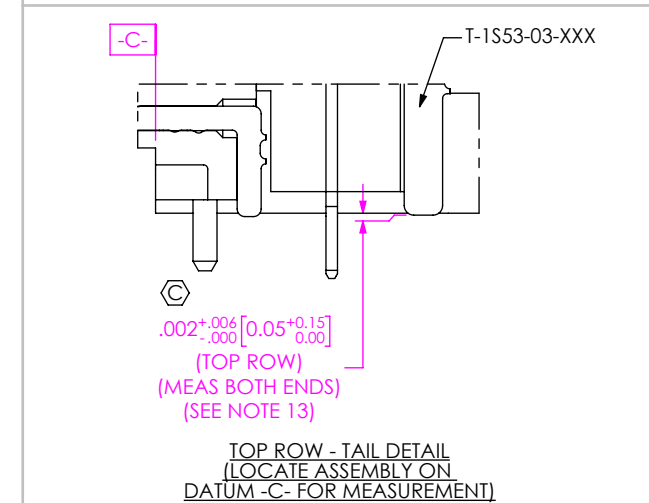
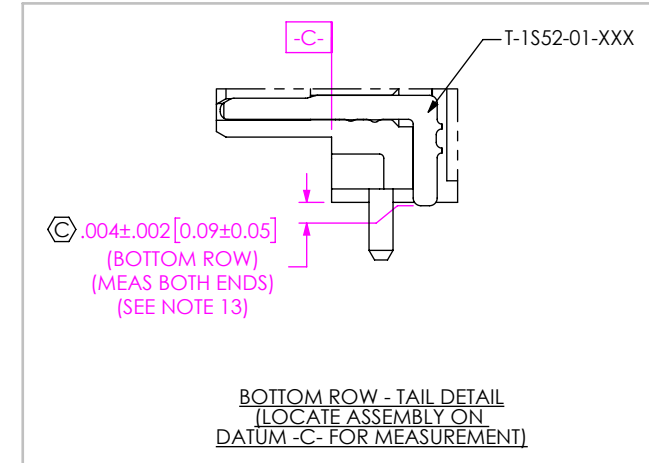
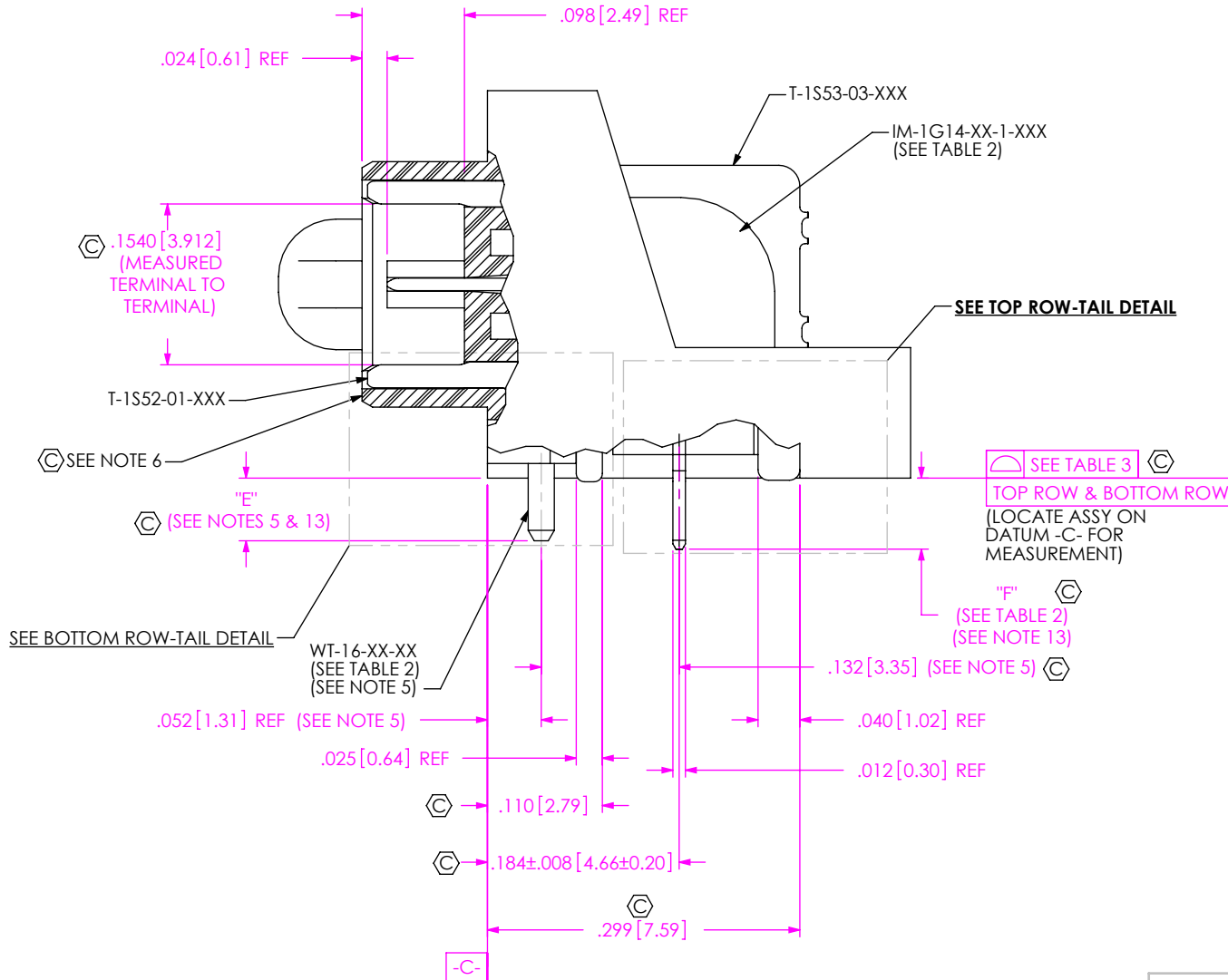

**PROPRIETARY NOTE**

THIS DOCUMENT CONTAINS CONFIDENTIAL AND PROPRIETARY INFORMATION AND ALL DESIGN, MANUFACTURING, REPRODUCTION, USE, PATENT RIGHTS AND SALES RIGHTS ARE EXPRESSLY RESERVED BY SAMTEC, INC. THIS DOCUMENT SHALL NOT BE DISCLOSED, IN WHOLE OR PART, TO ANY UNAUTHORIZED PERSON OR ENTITY NOR REPRODUCED, TRANSFERRED OR INCORPORATED IN ANY OTHER PROJECT IN ANY MANNER WITHOUT THE EXPRESS WRITTEN CONSENT OF SAMTEC, INC.

DO NOT SCALE DRAWING

SHEET SCALE: 6:1



520 PARK EAST BLVD, NEW ALBANY, IN 47150  
 PHONE: 812-944-6733 FAX: 812-948-5047  
 e-Mail info@SAMTEC.com code 55322

DESCRIPTION:  
 .635mm DOUBLE ROW RIGHT ANGLE TERMINAL STRIP

DWG. NO.  
**QTS-XXX-XX-XXX-D-RA-XX-XXX**

BY: KEVIN B 08/03/01 SHEET 2 OF 5

**INSPECTION VIEW 1**  
(FILL BOTTOM ROW)

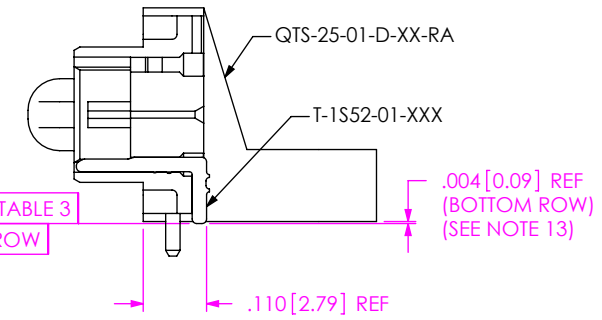
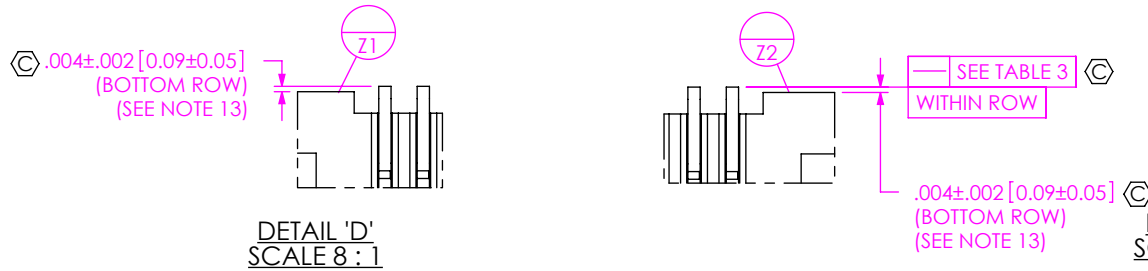
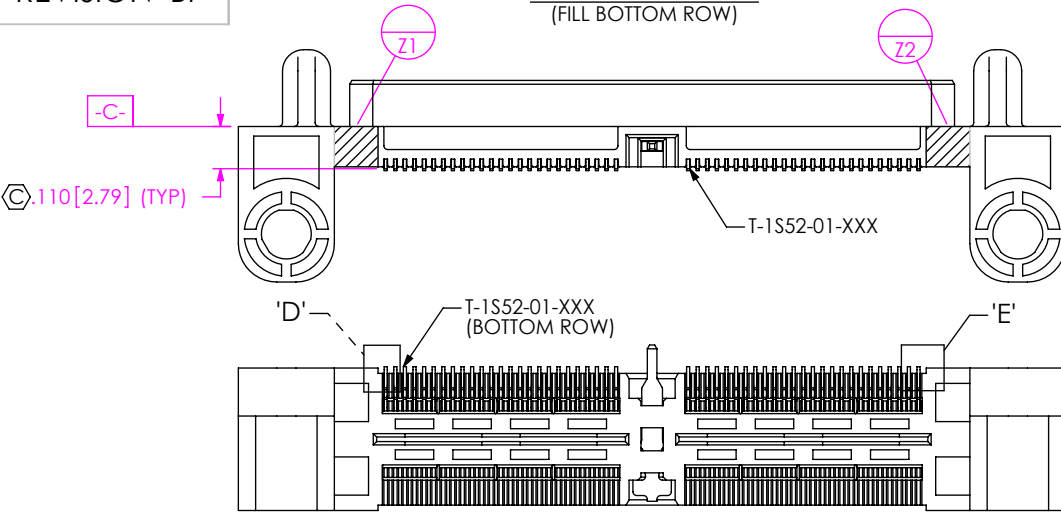

**IN-PROCESS 1**  
(FILL BOTTOM ROW)  
(SEE INSPECTION VIEW 1 FOR ORIENTATION AND CPC'S)

**INSPECTION VIEW 2**  
(FILL IM-1G14)

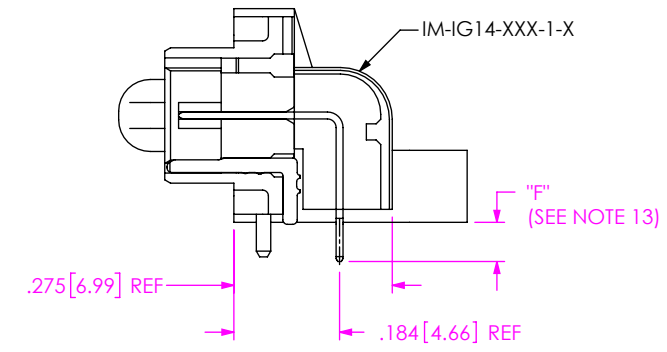
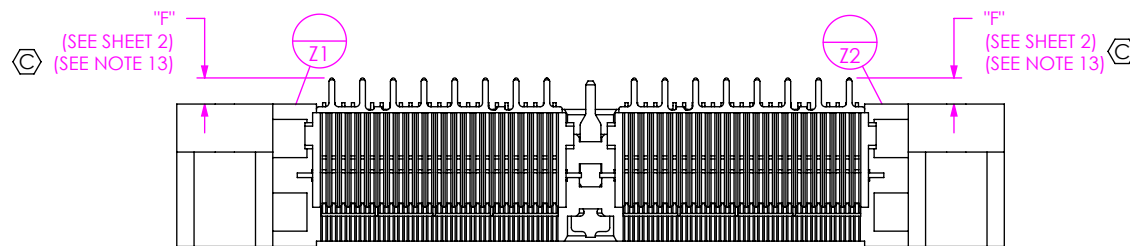
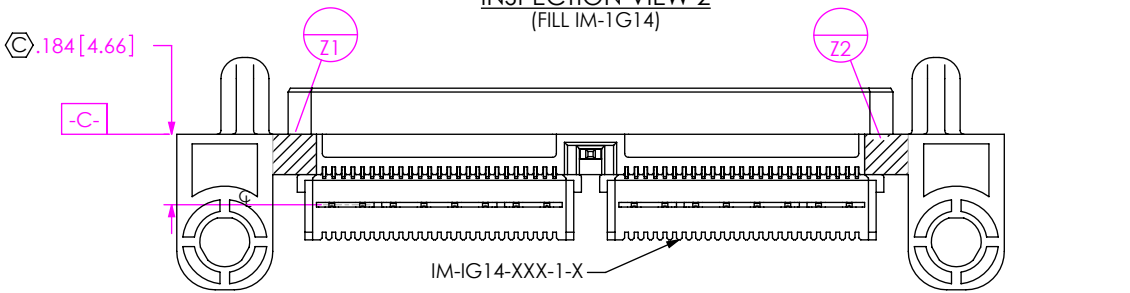

**IN-PROCESS 2**  
(FILL IM-1G14)  
(SEE INSPECTION VIEW 2 FOR ORIENTATION AND CPC'S)

**PROPRIETARY NOTE**  
THIS DOCUMENT CONTAINS CONFIDENTIAL AND PROPRIETARY INFORMATION AND ALL DESIGN, MANUFACTURING, REPRODUCTION, USE, PATENT RIGHTS AND SALES RIGHTS ARE EXPRESSLY RESERVED BY SAMTEC, INC. THIS DOCUMENT SHALL NOT BE DISCLOSED, IN WHOLE OR PART, TO ANY UNAUTHORIZED PERSON OR ENTITY NOR REPRODUCED, TRANSFERRED OR INCORPORATED IN ANY OTHER PROJECT IN ANY MANNER WITHOUT THE EXPRESS WRITTEN CONSENT OF SAMTEC, INC.



520 PARK EAST BLVD, NEW ALBANY, IN 47150  
PHONE: 812-944-6733 FAX: 812-948-5047  
e-Mail info@SAMTEC.com code 55322

DO NOT SCALE DRAWING

SHEET SCALE: 6:1

DESCRIPTION:  
.635mm DOUBLE ROW RIGHT ANGLE TERMINAL STRIP

DWG. NO.  
**QTS-XXX-XX-XXX-D-RA-XX-XXX**

BY: KEVIN B 08/03/01 SHEET 3 OF 5

INSPECTION VIEW 3  
(FILL TOP ROW)

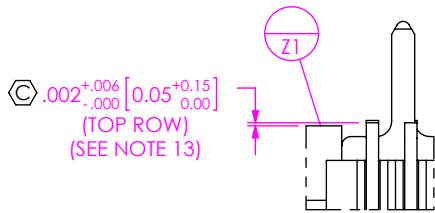
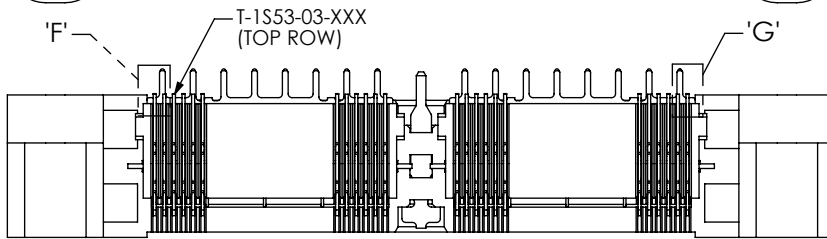
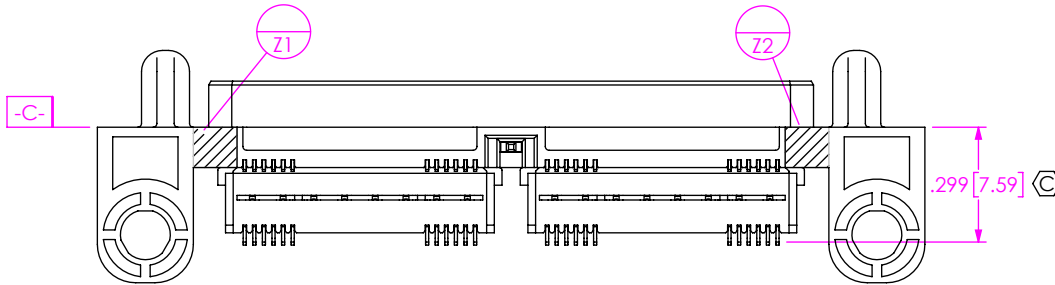
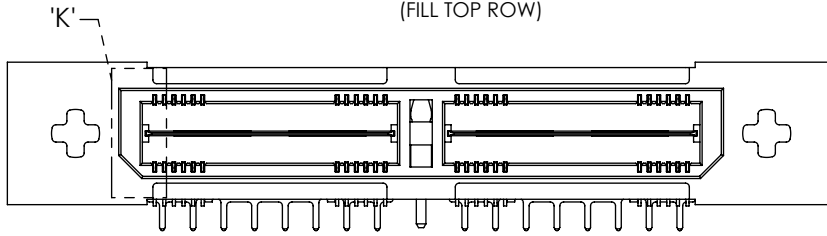

DETAIL 'F'  
SCALE 8:1

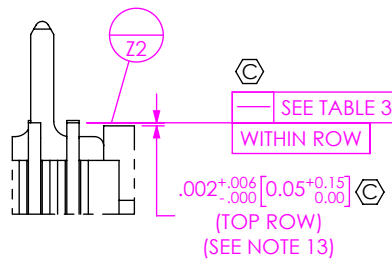

DETAIL 'G'  
SCALE 8:1

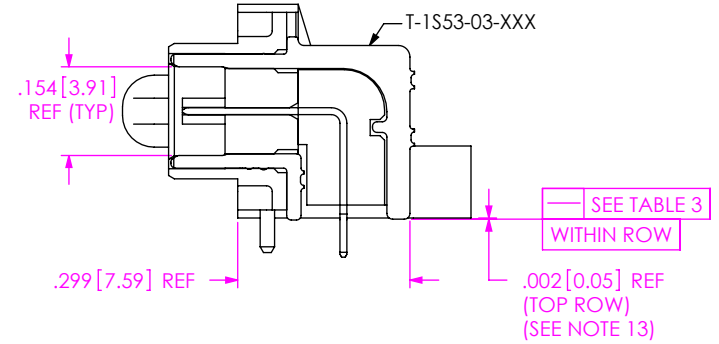

IN-PROCESS 3  
(FILL TOP ROW)  
(SEE INSPECTION VIEW 3 FOR ORIENTATION AND CPC'S)

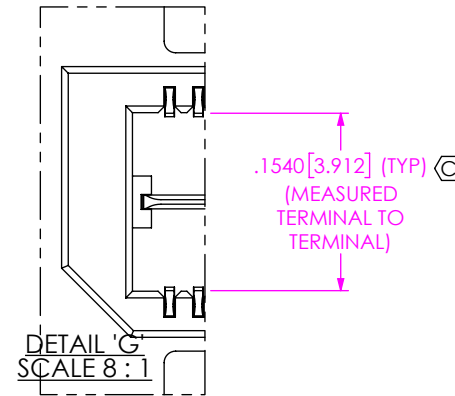

DETAIL 'G'  
SCALE 6:1

TABLE 4: PLATING SPECIFICATIONS (SEE NOTE 7)

|      | CONTACT   | CONTACT   | GROUND PLANE   |
|------|---|---|--|
| -F   | T-1S52-01-F: 3µ" FLASH GOLD CONTACT, MATTE TIN TAIL                     | T-1S53-03-F: 3µ" FLASH GOLD CONTACT, MATTE TIN TAIL                     | IM-1G14-XX-F: 3µ" FLASH GOLD CONTACT, MATTE TIN TAIL                     |
| -L   | T-1S52-01-L: 10µ" LIGHT GOLD CONTACT, MATTE TIN TAIL                    | T-1S53-03-L: 10µ" LIGHT GOLD CONTACT, MATTE TIN TAIL                    | IM-1G14-XX-L: 10µ" LIGHT GOLD CONTACT, MATTE TIN TAIL                    |
| -H   | T-1S52-01-H: 30µ" HEAVY GOLD CONTACT, 3µ" FLASH GOLD TAIL               | T-1S53-03-H: 30µ" HEAVY GOLD CONTACT, 3µ" FLASH GOLD TAIL               | IM-1G14-XX-L: 10µ" LIGHT GOLD CONTACT, MATTE TIN TAIL                    |
| -STL | T-1S52-01-STL: 30µ" SELECTIVE GOLD CONTACT, TIN/LEAD (90/10 +/-5%) TAIL | T-1S53-03-STL: 30µ" SELECTIVE GOLD CONTACT, TIN/LEAD (90/10 +/-5%) TAIL | IM-1G14-XX-STL: 30µ" SELECTIVE GOLD CONTACT, TIN/LEAD (90/10 +/-5%) TAIL |
| -FTL | T-1S52-01-FTL: 3µ" FLASH GOLD CONTACT, TIN/LEAD (90/10 +/-5%) TAIL      | T-1S53-03-FTL: 3µ" FLASH GOLD CONTACT, TIN/LEAD (90/10 +/-5%) TAIL      | IM-1G14-XX-FTL: 3µ" FLASH GOLD CONTACT, TIN/LEAD (90/10 +/-5%) TAIL      |

**PROPRIETARY NOTE**  
THIS DOCUMENT CONTAINS CONFIDENTIAL AND PROPRIETARY INFORMATION AND ALL DESIGN, MANUFACTURING, REPRODUCTION, USE, PATENT RIGHTS AND SALES RIGHTS ARE EXPRESSLY RESERVED BY SAMTEC, INC. THIS DOCUMENT SHALL NOT BE DISCLOSED, IN WHOLE OR PART, TO ANY UNAUTHORIZED PERSON OR ENTITY NOR REPRODUCED, TRANSFERRED OR INCORPORATED IN ANY OTHER PROJECT IN ANY MANNER WITHOUT THE EXPRESS WRITTEN CONSENT OF SAMTEC, INC.

DO NOT SCALE DRAWING  
SHEET SCALE: 1.5:1



520 PARK EAST BLVD, NEW ALBANY, IN 47150  
PHONE: 812-944-6733 FAX: 812-948-5047  
e-Mail info@SAMTEC.com code 55322

DESCRIPTION:  
.635mm DOUBLE ROW RIGHT ANGLE TERMINAL STRIP  
DWG. NO.  
**QTS-XXX-XX-XXX-D-RA-XX-XXX**  
BY: KEVIN B 08/03/01 SHEET 4 OF 5

$\phi .100 [2.54]$  REF  
(STS SCREW REMOVED FOR CLARITY)

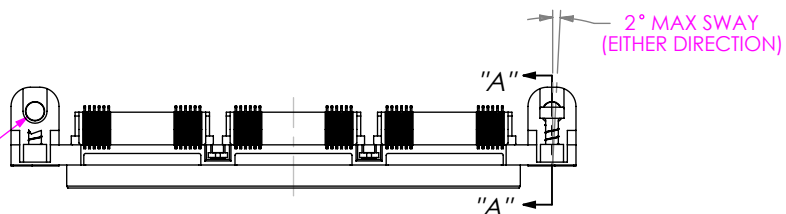

QTS-25-01-D-XX-RA-LS1

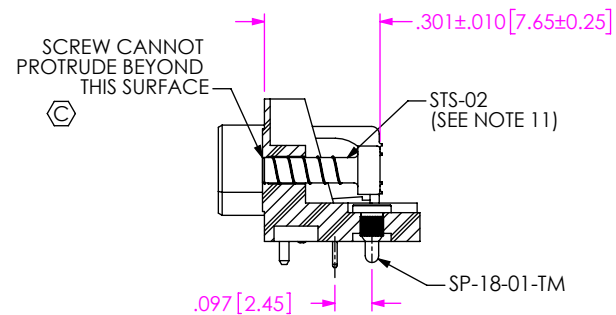
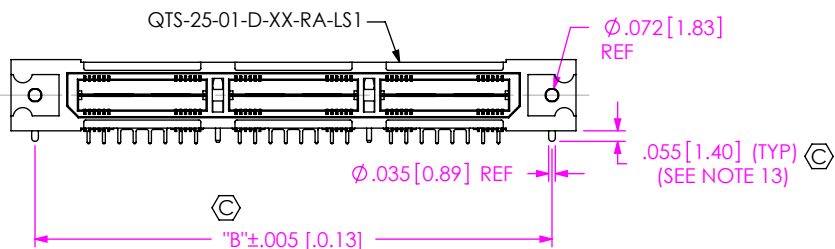

SECTION "A"- "A"  
SCALE 2:1

FIG 2

-LS1 OPTION  
(QTS-075-01-XXX-D-RA-WT-LS1 SHOWN)  
(SAME AS FIG 1, EXCEPT AS SHOWN)  
(AVAILABLE ON -01 LEADSTYLE ONLY)

QTS-25-01-D-XX-RA-LS2

$\phi .096 [2.44]$  REF  
(CLEARANCE HOLE FOR USE WITH 2-56 SCREW)

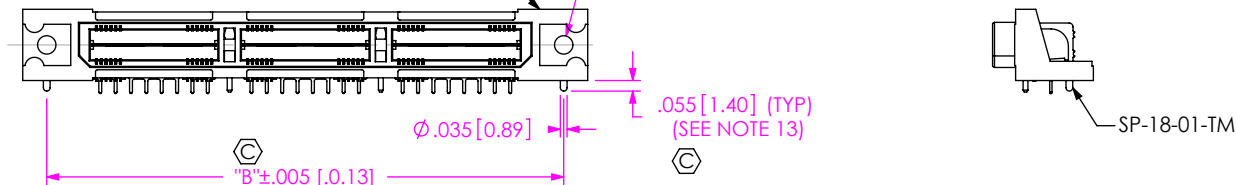

FIG 3  
-LS2 OPTION  
(QTS-075-01-XXX-D-RA-WT-LS2 SHOWN)  
(SAME AS FIG 2, EXCEPT AS SHOWN)

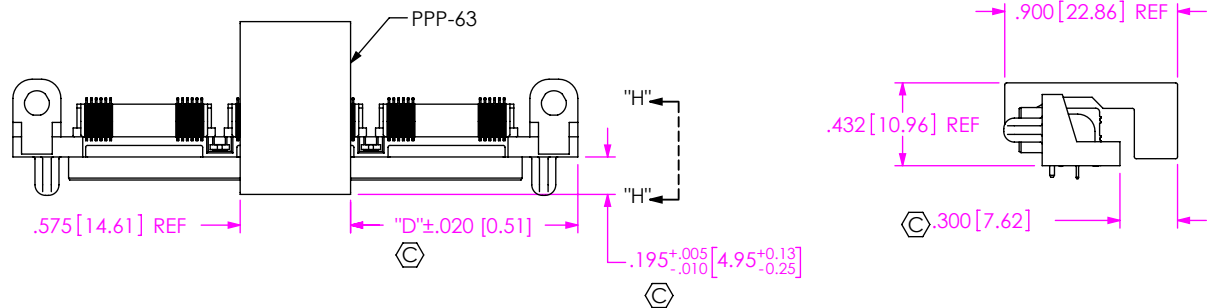

FIG 4  
-P OPTION  
(QTS-075-01-XXX-D-RA-WT-P SHOWN)  
(SAME AS FIG 1, EXCEPT AS SHOWN)

VIEW "H"- "H"  
SCALE 1 : 1

(ROTATED 90° CW)

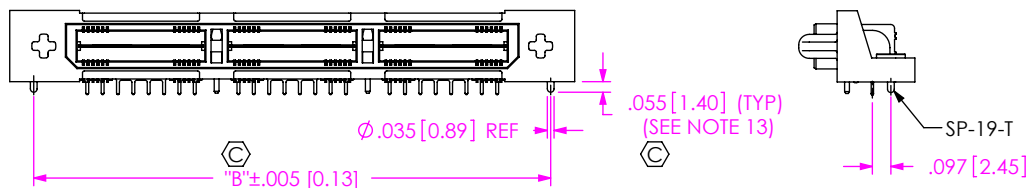

FIG 5  
-SP OPTION  
(QTS-075-01-XXX-D-RA-WT-SP SHOWN)  
(SAME AS FIG 1, EXCEPT AS SHOWN)

**PROPRIETARY NOTE**  
THIS DOCUMENT CONTAINS CONFIDENTIAL AND PROPRIETARY INFORMATION AND ALL DESIGN, MANUFACTURING, REPRODUCTION, USE, PATENT RIGHTS AND SALES RIGHTS ARE EXPRESSLY RESERVED BY SAMTEC, INC. THIS DOCUMENT SHALL NOT BE DISCLOSED, IN WHOLE OR PART, TO ANY UNAUTHORIZED PERSON OR ENTITY NOR REPRODUCED, TRANSFERRED OR INCORPORATED IN ANY OTHER PROJECT IN ANY MANNER WITHOUT THE EXPRESS WRITTEN CONSENT OF SAMTEC, INC.

DO NOT SCALE DRAWING  
SHEET SCALE: 1.5:1



520 PARK EAST BLVD, NEW ALBANY, IN 47150  
PHONE: 812-944-6733 FAX: 812-948-5047  
e-Mail info@SAMTEC.com code 55322

DESCRIPTION:  
.635mm DOUBLE ROW RIGHT ANGLE TERMINAL STRIP

DWG. NO.  
QTS-XXX-XX-XXX-D-RA-XX-XXX

BY: KEVIN B 08/03/01 SHEET 5 OF 5