

FPF2180/82/83/84/86/87

Full Function Load Switch with Reverse Current Blocking

Features

- 1.8 to 5.5V Input Voltage Range
- Controlled Turn-On
- 200mA and 400mA Current Limit Options
- Undervoltage Lockout
- Thermal Shutdown
- <2 μ A Shutdown Current
- Auto Restart
- Fast Current limit Response Time
 - 5 μ s to Moderate Over Currents
 - 30ns to Hard Shorts
- Fault Blanking
- Reverse Current Blocking
- Power Good Function
- RoHS Compliant

Applications

- PDAs
- Cell Phones
- GPS Devices
- MP3 Players
- Digital Cameras
- Peripheral Ports
- Hot Swap Supplies



General Description

The FPF2180/82/83/84/86/87 is a series of load switches which provides full protection to systems and loads which may encounter large current conditions. These devices contain a 55m Ω current-limited P-channel MOSFET which can operate over an input voltage range of 1.8-5.5V. Internally, current is prevented from flowing when the MOSFET is off and the output voltage is higher than the input voltage. Switch control is by a logic input (ON) capable of interfacing directly with low voltage control signals. Each part contains thermal shutdown protection which shuts off the switch to prevent damage to the part when a continuous over-current condition causes excessive heating.

When the switch current reaches the current limit, the part operates in a constant-current mode to prohibit excessive currents from causing damage. For the FPF2180/82/84/86, if the constant current condition still persists after 30ms, the part will shut off the switch and pull the fault signal pin (FLAGB) low. The FPF2180/84 have an auto-restart feature which will turn the switch on again after 450ms if the ON pin is still active. The FPF2182/86 do not have this auto-restart feature so the switch will remain off until the ON pin is cycled. For the FPF2183/87, a current limit condition will immediately pull the fault signal pin low and the part will remain in the constant-current mode until the switch current falls below the current limit. The minimum current limit is 200mA for the FPF2180/82/83 while that for the FPF2184/86/87 is 400mA.

These parts are available in a space-saving 6 ball advanced Pb-Free 1 x 1.5 mm CSP package.

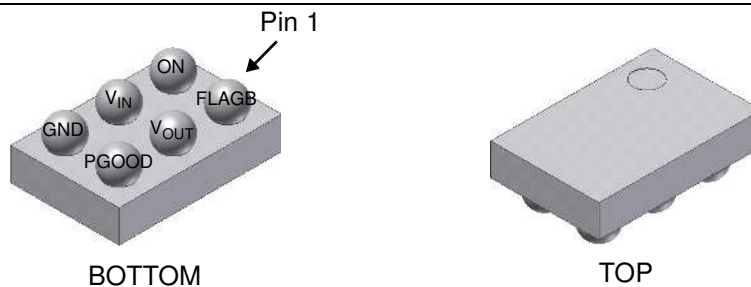

Ordering Information

Part	Current Limit [mA]	Current Limit Blanking Time [ms]	Auto-Restart Time [ms]	ON Pin Activity	Top Mark
FPF2180	200/300/400	15/30/60	225/450/900	Active HI	A
FPF2182	200/300/400	15/30/60	NA	Active HI	B
FPF2183	200/300/400	0	NA	Active HI	C
FPF2184	400/600/800	15/30/60	225/450/900	Active HI	D
FPF2186	400/600/800	15/30/60	NA	Active HI	E
FPF2187	400/600/800	0	NA	Active HI	F

Typical Application Circuit

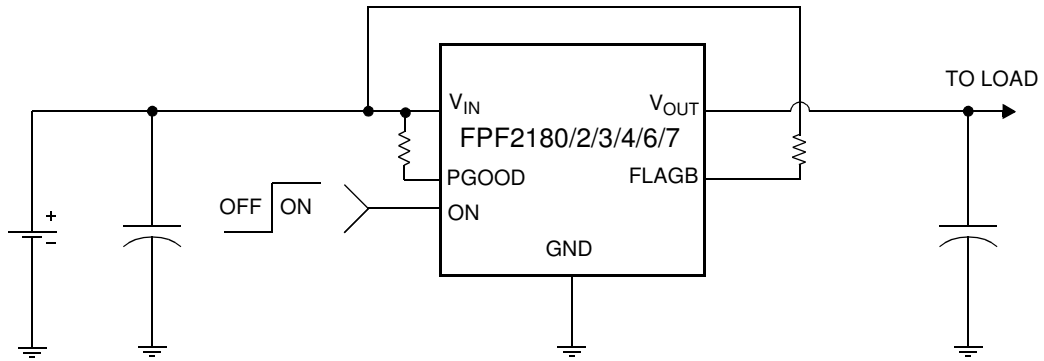

Functional Block Diagram

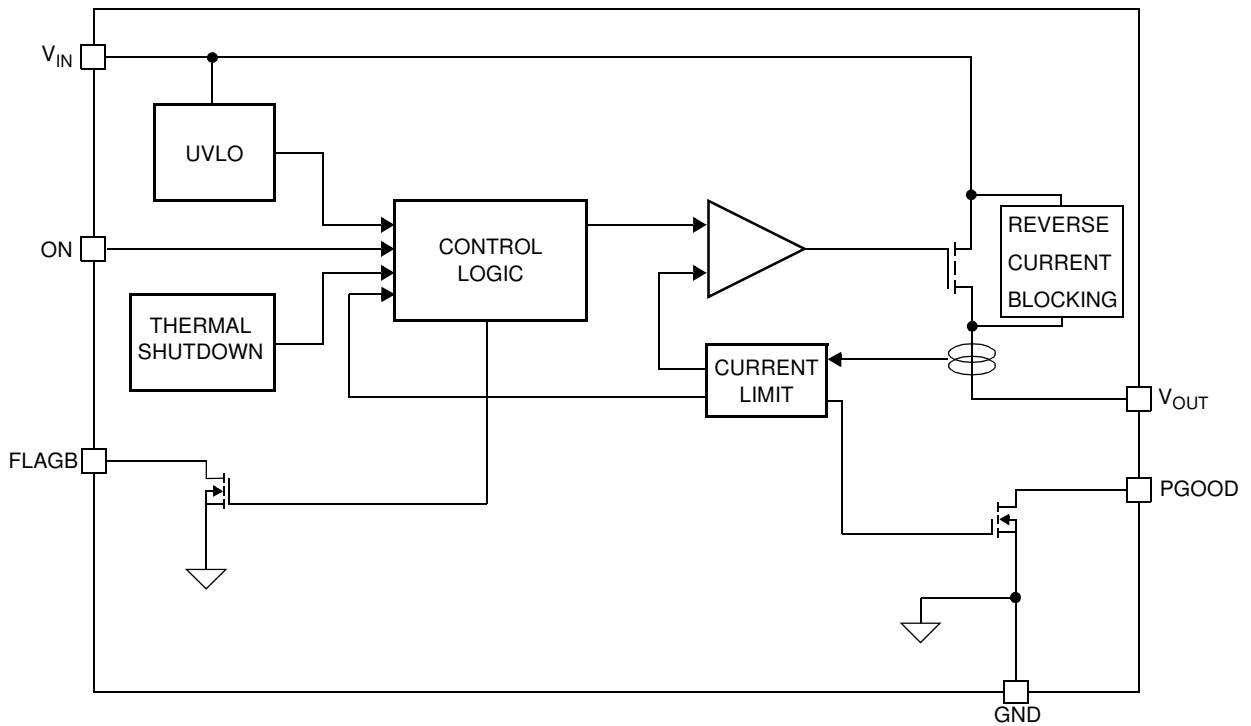

Pin Configuration

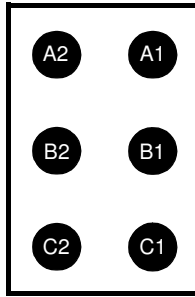

1.0 x 1.5 CSP Bottom View

Pin Description

Pin	Name	Function
C1	PGOOD	Power Good output: Open drain output which indicate that output voltage has reached 90% of input voltage
B2	V _{IN}	Supply Input: Input to the power switch and the supply voltage for the IC
B1	V _{OUT}	Switch Output: Output of the power switch
A1	FLAGB	Fault Output: Active LO, open drain output which indicates an over current supply under voltage or over temperature state.
C2	GND	Ground
A2	ON	ON Control Input

Absolute Maximum Ratings

Parameter	Min.	Max.	Unit
V _{IN} , V _{OUT} , ON, FLAGB, PGOOD to GND	-0.3	6	V
Power Dissipation @ T _A = 25°C (Note 1)		1.2	W
Operating Temperature Range	-40	125	°C
Storage Temperature	-65	150	°C
Thermal Resistance, Junction to Ambient		85	°C/W
Electrostatic Discharge Protection	HBM	8000	V
	MM	400	V

Recommended Operating Range

Parameter	Min.	Max.	Unit
V _{IN}	1.8	5.5	V
Ambient Operating Temperature, T _A	-40	85	°C

Electrical Characteristics

V_{IN} = 1.8 to 5.5V, T_A = -40 to +85°C unless otherwise noted. Typical values are at V_{IN} = 3.3V and T_A = 25°C.

Parameter	Symbol	Conditions	Min.	Typ.	Max.	Units
Basic Operation						
Operating Voltage	V _{IN}		1.8		5.5	V
Quiescent Current	I _Q	I _{OUT} = 0mA V _{ON} = V _{IN}	V _{IN} = 1.8V		70	μA
			V _{IN} = 3.3V		75	
			V _{IN} = 5.5V		85	
On-Resistance	R _{ON}	T _A = 25°C, I _{OUT} = 200mA		55	80	mΩ
		T _A = -40 to +85°C, I _{OUT} = 200mA			135	

Note 1: Package power dissipation on 1square inch pad, 2 oz. copper board.

Electrical Characteristics Cont.
 $V_{IN} = 1.8$ to $5.5V$, $T_A = -40$ to $+85^\circ C$ unless otherwise noted. Typical values are at $V_{IN} = 3.3V$ and $T_A = 25^\circ C$.

Parameter	Symbol	Conditions	Min.	Typ.	Max.	Units	
ON Input Logic High Voltage (ON)	V_{IH}	$V_{IN} = 1.8V$	0.8			V	
		$V_{IN} = 5.5V$	1.4				
ON Input Logic Low Voltage	V_{IL}	$V_{IN} = 1.8V$			0.5	V	
		$V_{IN} = 5.5V$			1.0		
ON Input Leakage		$V_{ON} = V_{IN}$ or GND	-1	0	1	μA	
V_{IN} Shutdown Current		$V_{ON} = 0V$, $V_{IN} = 5.5V$, $V_{OUT} =$ short to GND	-2		2	μA	
FLAGB Output Logic Low Voltage		$V_{IN} = 5V$, $I_{SINK} = 10mA$		0.05	0.2	V	
		$V_{IN} = 1.8V$, $I_{SINK} = 10mA$		0.12	0.3		
FLAGB Output High Leakage Current		$V_{IN} = V_{ON} = 5V$			1	μA	
PGOOD Threshold Voltage				90		%	
PGOOD Threshold Voltage Hysteresis				1		%	
PGOOD Output Logic Low Voltage		$V_{IN} = 5V$, $I_{SINK} = 10mA$		0.05	0.2	V	
		$V_{IN} = 1.8V$, $I_{SINK} = 10mA$		0.12	0.3	V	
PGOOD Output High Leakage Current		$V_{IN} = 5V$, Switch ON			1	μA	
Reverse Block							
V_{OUT} Shutdown Current		$V_{ON} = 0V$, $V_{OUT} = 5.5V$, $V_{IN} =$ short to GND	-2		2	μA	
Reverse Breakdown Voltage	$V_{breakdown}$	$V_{IN} = V_{ON} = 0V$, $I_{OUT} = 200\mu A$		9		V	
Protections							
Current Limit	I_{LIM}	$V_{IN} = 3.3V$, $V_{OUT} = 3.0V$	FPF2180 FPF2182 FPF2183	200	300	400	mA
			FPF2184 FPF2186 FPF2187	400	600	800	
Thermal Shutdown		Shutdown Threshold T_J increasing		140		$^\circ C$	
		Return from Shutdown		130		$^\circ C$	
		Hysteresis		10		$^\circ C$	
Under Voltage Lockout	V_{UVLO}	V_{IN} Increasing	1.55	1.65	1.75	V	
Under Voltage Lockout Hysteresis				50		mV	
Dynamic							
Delay On Time	t_{dON}	$R_L = 500\Omega$, $C_L = 0.1\mu F$		20		μs	
V_{OUT} Rise Time	t_R	$R_L = 500\Omega$, $C_L = 0.1\mu F$		20		μs	
Turn On Time	t_{ON}	$R_L = 500\Omega$, $C_L = 0.1\mu F$		40		μs	
Delay Off Time	t_{dOFF}	$R_L = 500\Omega$, $C_L = 0.1\mu F$		15		μs	
V_{OUT} Fall Time	t_F	$R_L = 500\Omega$, $C_L = 0.1\mu F$		110		μs	
Turn Off Time	t_{OFF}	$R_L = 500\Omega$, $C_L = 0.1\mu F$		125		μs	
Over Current Blanking Time	t_{BLANK}	FPF2180, FPF2182, FPF2184, FPF2186	15	30	60	ms	
Auto-Restart Time	t_{RSTRT}	FPF2180, FPF2184	225	450	900	ms	
Short Circuit Response Time		$V_{IN} = V_{ON} = 3.3V$. Moderate Over-Current Condition		5		μs	
		$V_{IN} = V_{ON} = 3.3V$. Hard Short		30		ns	

Typical Characteristics

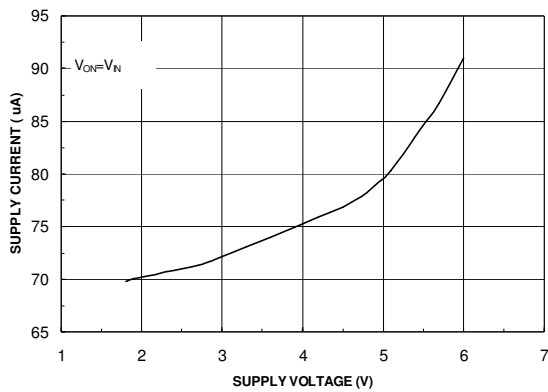

Figure 1. Quiescent Current vs. Input Voltage

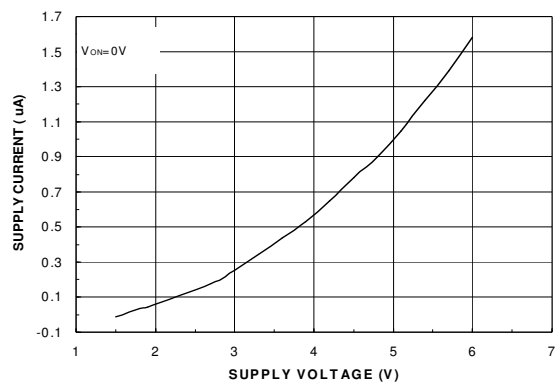

Figure 2. Quiescent Current vs. Input Voltage

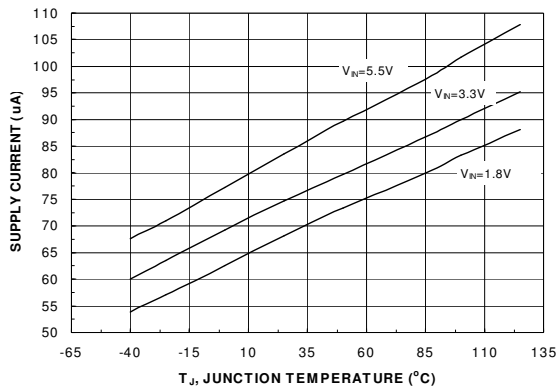

Figure 3. Quiescent Current vs. Temperature

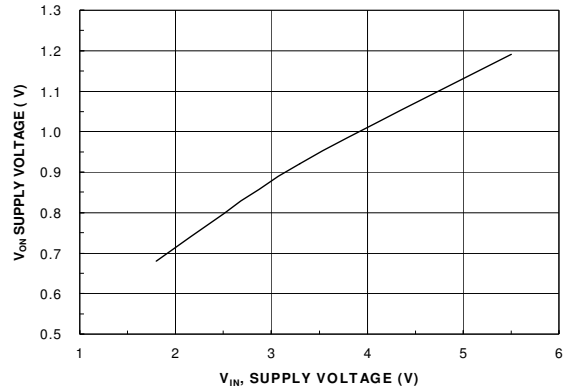

Figure 4. V_{ON} High Voltage vs. Input Voltage

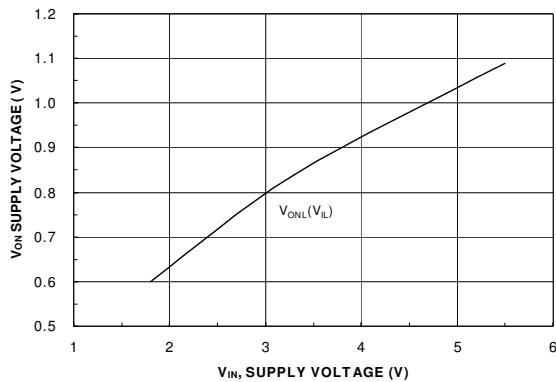

Figure 5. V_{ON} Low Voltage vs. Input Voltage

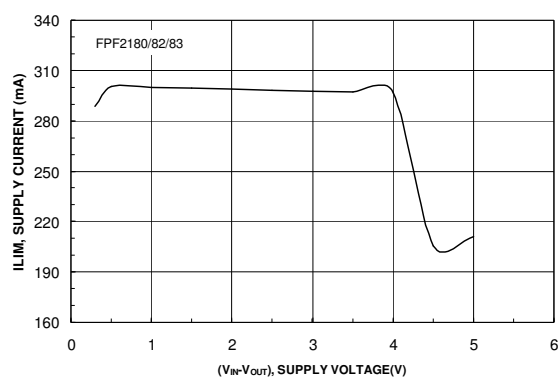

Figure 6. Current Limit vs. Output Voltage

Typical Characteristics

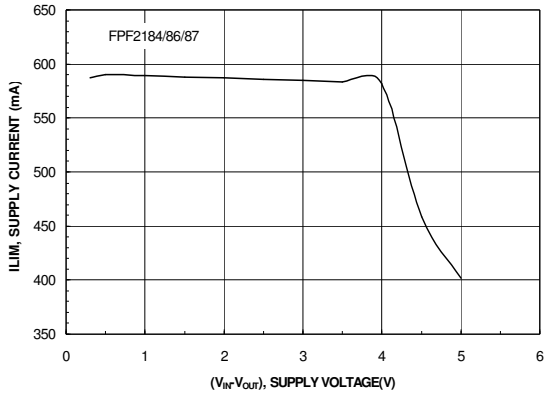

Figure 7. Current Limit vs. Output Voltage

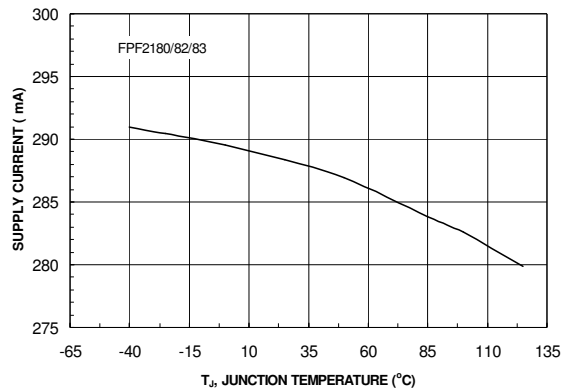

Figure 8. Current Limit vs. Temperature

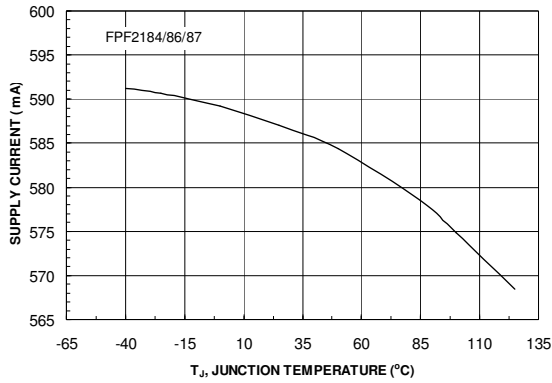

Figure 9. Current Limit vs. Temperature

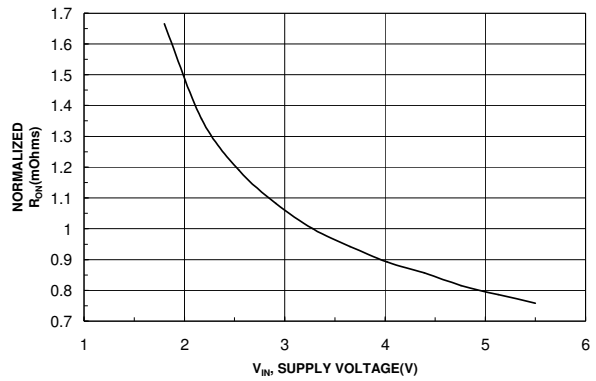

Figure 10. R_{ON} vs. V_{IN}

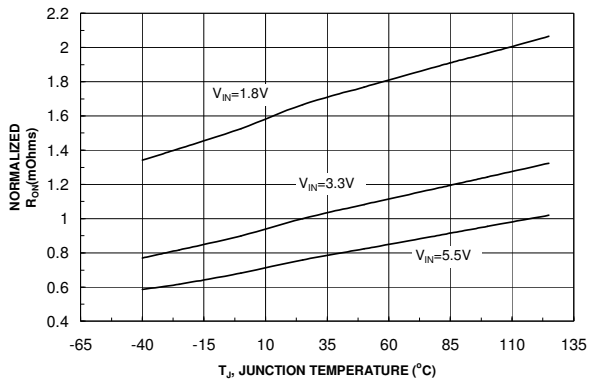

Figure 11. R_{ON} vs. Temperature

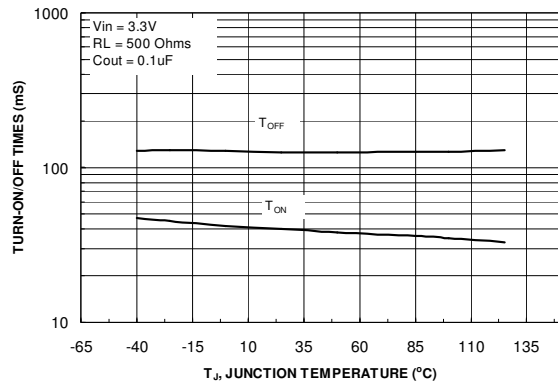

Figure 12. T_{ON} / T_{OFF} vs. Temperature

Typical Characteristics

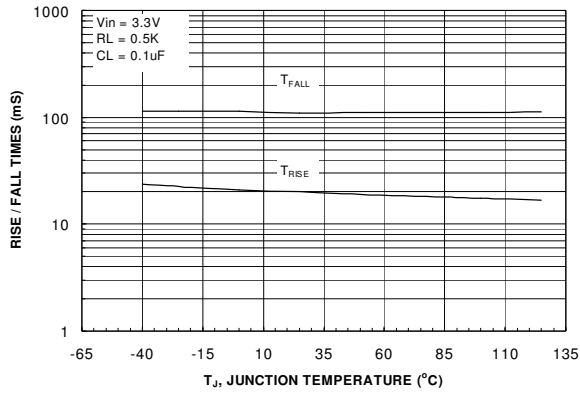

Figure 13. T_{RISE} / T_{FALL} vs. Temperature

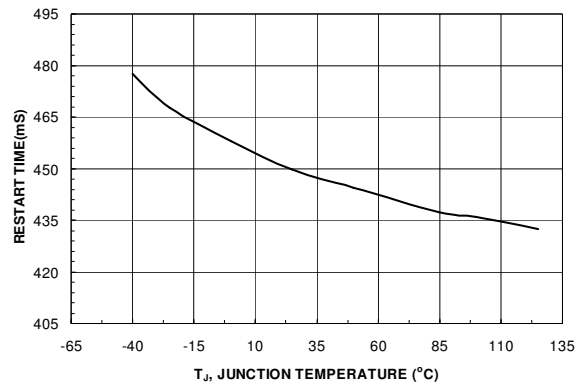

Figure 14. $T_{RESTART}$ vs. Temperature

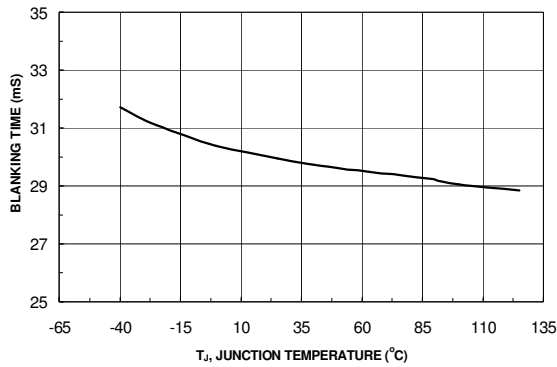

Figure 15. T_{BLANK} vs. Temperature

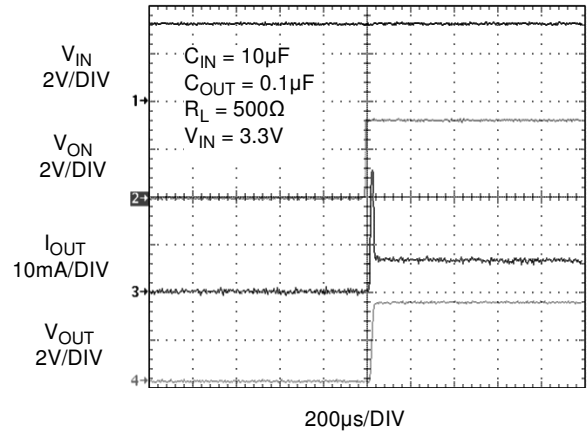

Figure 16. T_{ON} Response

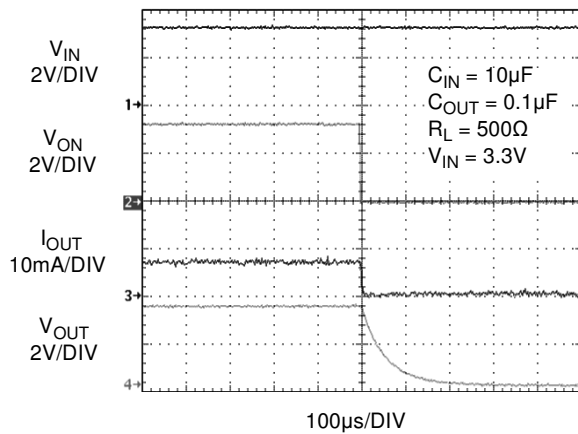

Figure 17. T_{OFF} Response

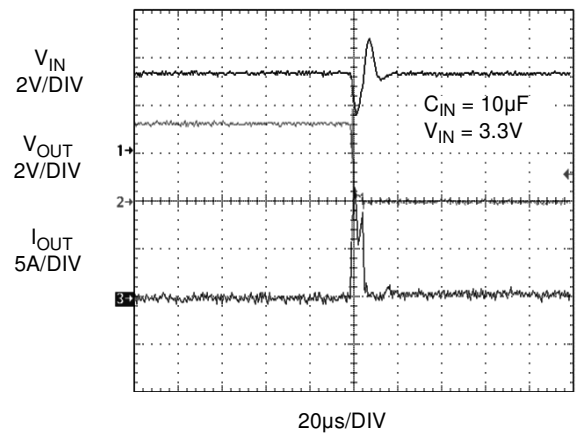

Figure 18. Short Circuit Response Time (Output shorted to ground)

Typical Characteristics

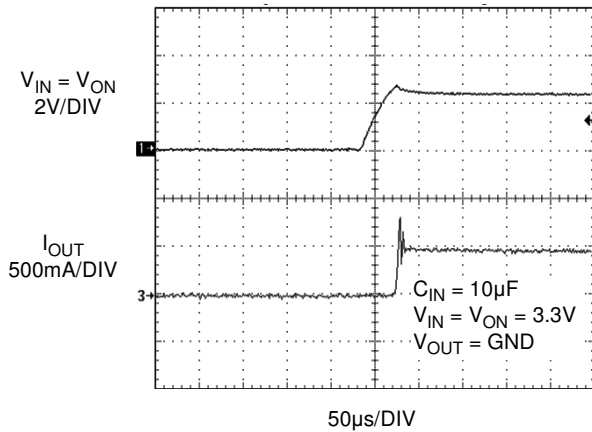

Figure 19. Current Limit Response Time (Switch is powered to a short)

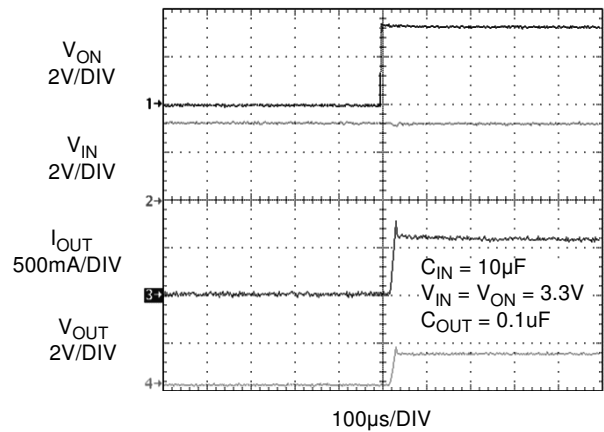

Figure 20. Current Limit Response Time (Output is loaded by 2.2Ω, C_OUT = 0.1µF)

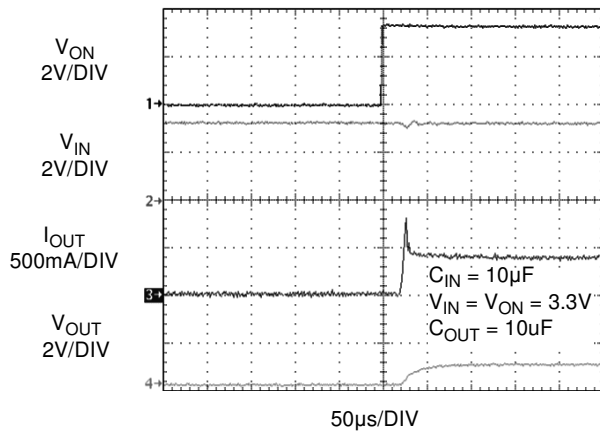

Figure 21. Current Limit Response Time (Output is loaded by 2.2Ω, C_OUT = 10µF)

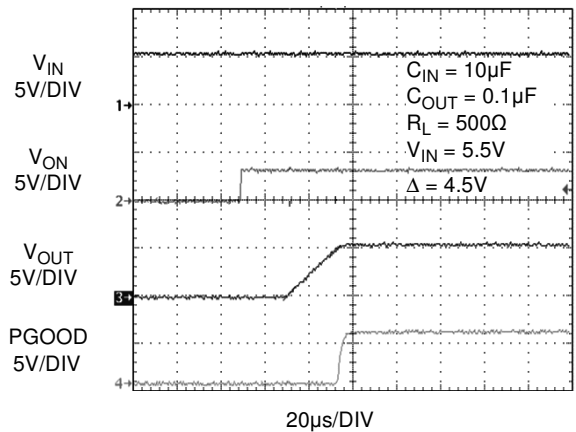

Figure 22. PGOOD Response

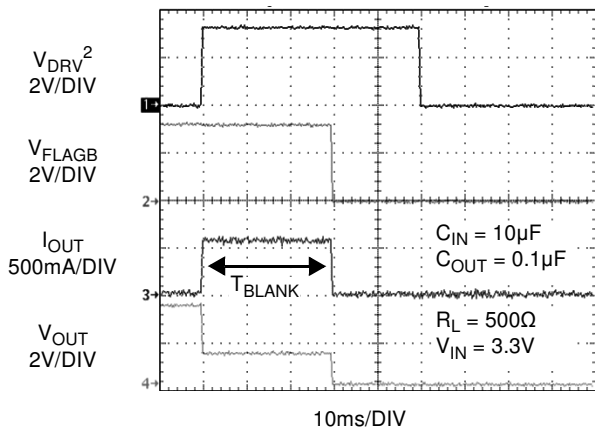

Figure 23. T_{BLANK} Response

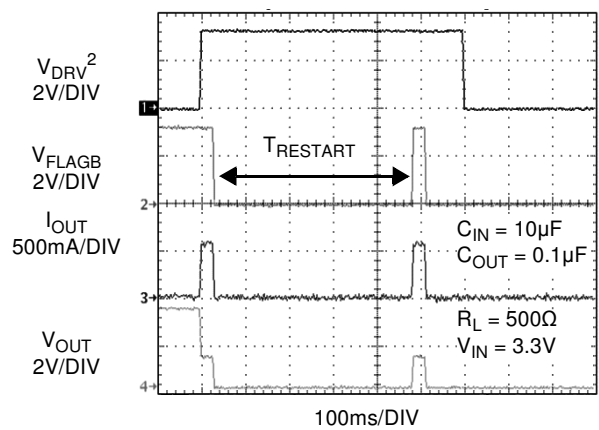

Figure 24. T_{RESTART} Response

Note 2: V_{DRV} signal forces the device to go into overcurrent condition by loading a 2.2Ω resistor.

Typical Characteristics

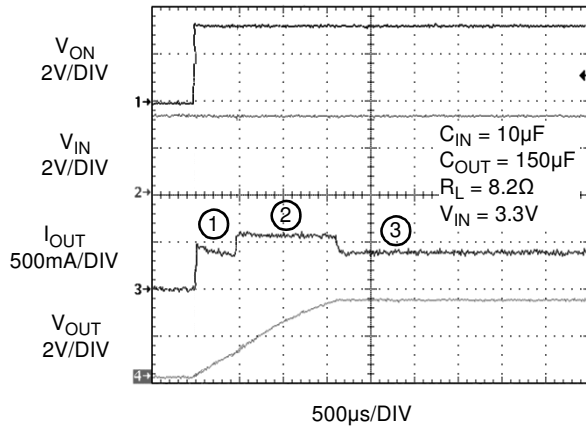

Figure 25. Switch is turned on into a large output capacitor
 1.Short circuit detection.

When the output voltage is below $V_{SCTH}=1.1V$, the current limit value is set at 62.5% of the current limit value.

2. Current limit condition.

Due to the large charging current of the output capacitor the load switch is still in the current limiting mode.

3. Normal operation.

Output current is below the current limit value

Description of Operation

The FPF2180/82/83/84/86/87 are current limited switches that protect systems and loads which can be damaged or disrupted by the application of high currents. The core of each device is a 55mΩ P-channel MOSFET and a controller capable of functioning over a wide input operating range of 1.8-5.5V. The controller protects against system malfunctions through current limiting, under-voltage lockout and thermal shutdown. The current limit is preset for either 200mA or 400mA.

On/Off Control

The ON pin controls the state of the switch. Activating ON continuously holds the switch in the on state so long as there is no under-voltage on V_{IN} or a junction temperature in excess of 140°C. ON is active HI and has a low threshold making it capable of interfacing with low voltage signals. In addition, excessive currents will cause the switch to turn off for FPF2180/82 and FPF2184/86. The FPF2180/84 have an Auto-Restart feature which will automatically turn the switch on again after 450ms. For the FPF2182/86, the ON pin must be toggled to turn-on the switch again. The FPF2183/87 do not turn off in response to a over current condition but instead remain operating in a constant current mode so long as ON is active and the thermal shutdown or under-voltage lockout have not activated.

Fault Reporting

Upon the detection of an over-current, an input under-voltage, or an over-temperature condition, the FLAGB signals the fault mode by activating LO. For the FPF2180/82/84/86, the FLAGB goes LO at the end of the blanking time while FLAGB goes LO immediately for the FPF2183/87. FLAGB remains LO through the Auto-Restart Time for the FPF2180/84. For the FPF2182/86, FLAGB is latched LO and ON must be toggled to release it. With the FPF2183/87, FLAGB is LO during the faults and immediately returns HI at the end of the fault condition. FLAGB is an open-drain MOSFET which requires a pull-up resistor between V_{IN} and FLAGB. During shutdown, the pull-down on FLAGB is disabled to reduce current draw from the supply.

Current Limiting

The current limit guarantees that the current through the switch doesn't exceed a maximum value while not limiting at less than a minimum value. For the FPF2180/82/83 the minimum current is 200mA and the maximum current is 400mA and for the FPF2184/86/87 the minimum current is 400mA and the maximum current is 800mA. The FPF2180/82/84/86 have a blanking time of 30ms, nominally, during which the switch will act as a constant current source. At the end of the blanking time, the switch will be turned-off and the FLAGB pin will activate to indicate that current limiting has occurred. The FPF2183/87 have no current limit blanking period so immediately upon a current limit condition FLAGB is activated. These parts will remain in a constant current state until the ON pin is deactivated or the thermal shutdown turns-off the switch.

For preventing the switch from large power dissipation during heavy load a short circuit detection feature is introduced. Short circuit condition is detected by observing the output voltage. The switch is put into short circuit current limiting mode if the switch is loaded with a heavy load. When the output voltage

drops below V_{SCTH} , short circuit detection threshold voltage, the current limit value re-conditioned and short circuit current limit value is decreased to 62.5% of the current limit value. This keeps the power dissipation of the part below a certain limit even at dead short conditions at 5.5V input voltage. The V_{SCTH} value is set to be 1V. At around 1.1V of output voltage the switch is removed from short circuit current limiting mode and the current limit is set to the current limit value.

Under-Voltage Lockout

The under-voltage lockout turns-off the switch if the input voltage drops below the under-voltage lockout threshold. With the ON pin active the input voltage rising above the under-voltage lockout threshold will cause a controlled turn-on of the switch which limits current over-shoots.

Thermal Shutdown

The thermal shutdown protects the die from internally or externally generated excessive temperatures. During an over-temperature condition the FLAGB is activated and the switch is turned-off. The switch automatically turns-on again if temperature of the die drops below the threshold temperature.

Reverse Current Blocking

The entire FPF2180/82/83/84/86/87 family has a Reverse Current Blocking feature that protects input source against current flow from output to input. For a standard USB power design, this is an important feature which protects the USB host from being damaged due to reverse current flow on V_{BUS} .

When the load switch is OFF, no current flows from the output to the input. If the switch is turned on and the output voltage is greater than input voltage this feature is activated and turns off the switch. This will prevent any current flow from output to input. The reverse current blocking feature will be deactivated if the $V_{OUT} - V_{IN}$ is smaller than a typically 50mV threshold. During this time some current ($50mV/R_{ON}$) will flow from the output to input until input voltage become greater than output voltage. The FLAGB operation is independent of the Reverse Current blocking and will not report a fault condition if this feature is activated.

Timing Diagram

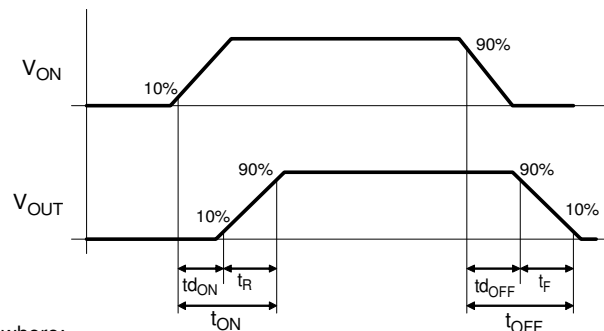

where:

- t_{dON} = Delay On Time
- t_R = V_{OUT} Rise Time
- t_{ON} = Turn On Time
- t_{dOFF} = Delay Off Time
- t_F = V_{OUT} Fall Time
- t_{OFF} = Turn Off Time

Application Information

Typical Application

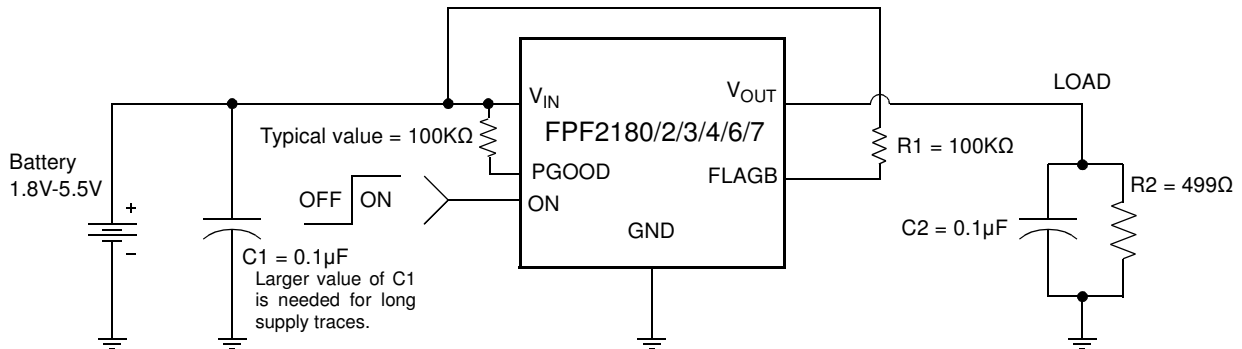

Input Capacitor

To limit the voltage drop on the input supply caused by transient in-rush currents when the switch turns-on into a discharged load capacitor or a short-circuit, a capacitor needs to be placed between V_{IN} and GND. A 0.1μF ceramic capacitor, C_{IN}, placed close to the pins is usually sufficient. Higher values of C_{IN} can be used to further reduce the voltage drop.

Output Capacitor

A 0.1μF capacitor C_{OUT}, should be placed between V_{OUT} and GND. This capacitor will prevent parasitic board inductances from forcing V_{OUT} below GND when the switch turns-off. For the FPF2180/82/84/86, the total output capacitance needs to be kept below a maximum value, C_{OUT(max)}, to prevent the part from registering an over-current condition and turning-off the switch. The maximum output capacitance can be determined from the following formula,

$$C_{OUT(max)} = \frac{I_{LIM(max)} \times t_{BLANK(min)}}{V_{IN}} \quad (1)$$

Power Dissipation

During normal operation as a switch, the power dissipation is small and has little effect on the operating temperature of the part. The parts with the higher current limits will dissipate the most power and that will only be,

$$P = (I_{LIM})^2 \times R_{ON} = (0.8)^2 \times 0.055 = 35.2mW \quad (2)$$

If the part goes into current limit the maximum power dissipation will occur when the output is shorted to ground. For the FPF2180/84, the power dissipation will scale by the Auto-Restart Time, t_{RSTRT}, and the Over Current Blanking Time, t_{BLANK}, so that the maximum power dissipated is,

$$P(max) = \frac{t_{BLANK}}{t_{BLANK} + t_{RSTRT}} \times V_{IN(max)} \times I_{LIM(max)}$$

$$= \frac{30}{30 + 450} \times 5.5 \times 0.8 = 275mW \quad (3)$$

When using the FPF2182/86, attention must be given to the manual resetting of the part. Continuously resetting the part at a high duty cycle when a short on the output is present can cause the temperature of the part to increase. The junction temperature will only be allowed to increase to the thermal shutdown threshold. Once this temperature has been reached, toggling ON will not turn-on the switch until the junction temperature drops. For the FPF2180/84, a short on the output will cause the part to operate in a constant current state dissipating a worst case power as calculated in (3) until the thermal shutdown activates. It will then cycle in and out of thermal shutdown so long as the ON pin is active and the short is present.

Board Layout

For best performance, all traces should be as short as possible. To be most effective, the input and output capacitors should be placed close to the device to minimize the effects that parasitic trace inductances may have on normal and short-circuit operation. Using wide traces for V_{IN}, V_{OUT} and GND will help minimize parasitic electrical effects along with minimizing the case to ambient thermal impedance.

Application Notes

Startup Power Sequence

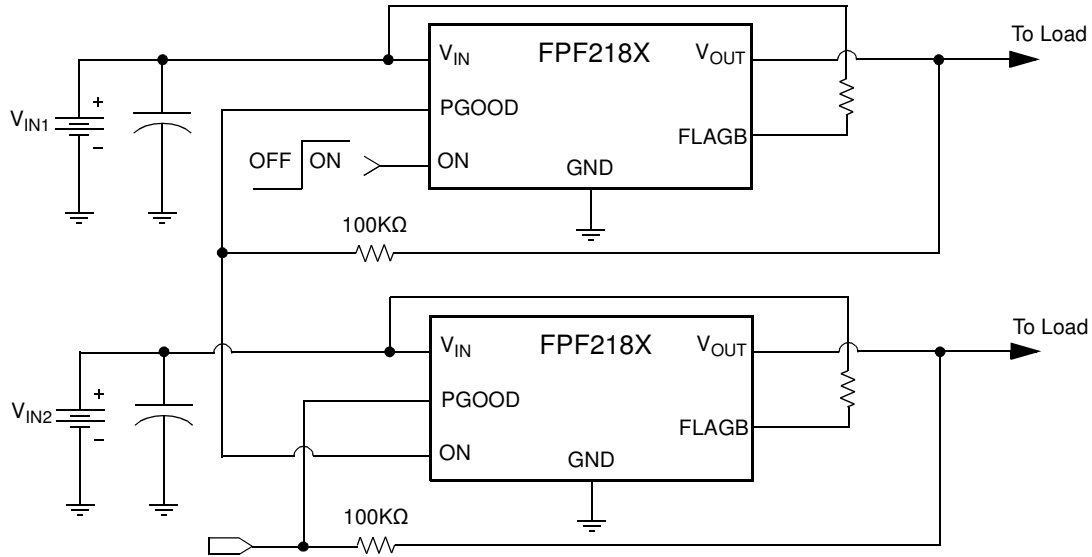

Power good function in sequential startup. No battery is loaded to the output

Power Good

FPF218X family has a "Power Good" feature. PGOOD pin is an open-drain MOSFET which asserts high when the output voltage reaches 90% of the input voltage.

PGOOD pin requires an external pull up resistor that is connected to the output voltage when there is no battery in the load side and the logic level of the subsequent controller permits. This would give logic levels similar to a CMOS output stage for PGOOD, while still keeping the option to tie the pull-up to a different supply voltage. A 100KΩ is recommended to be used as pull up resistor. The PGOOD pin status is independent of the ON pin position. This means that PGOOD pin stays low when the load switch is OFF. If the Power Good feature is not used in the application the pin can be connected directly to GND.

Sequential Startup using Power Good

The power good pin can be connected to another load switch's enable pin to implement sequential startup. PGOOD pin asserts low when the load switch is OFF. This feature allows driving a subsequent circuit. The diagram illustrates power good function in sequential startup. As the VOUT1 of the first load switch starts to ramp to the 90% of its input voltage the second switch remains in OFF state. Whereas the VOUT1 passes the 90% threshold, power good signal becomes active and asserts high. This signal will turn on the second load switch and VOUT2 will start to increase. The total startup time may vary according to the difference between supply voltages that are used in the application.

Dimensional Outline and Pad Layout

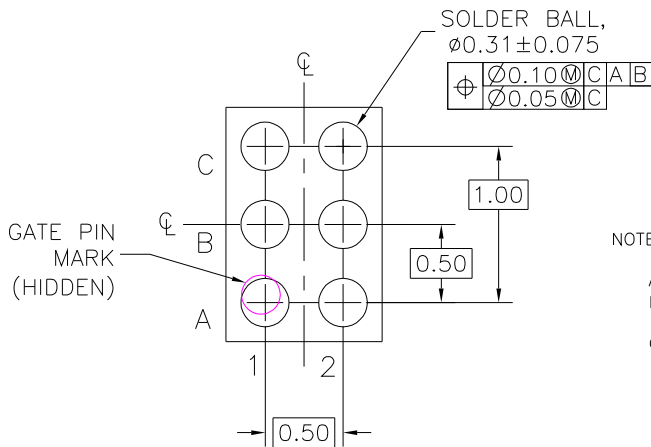
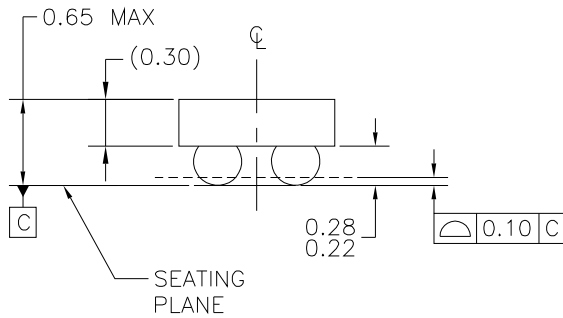
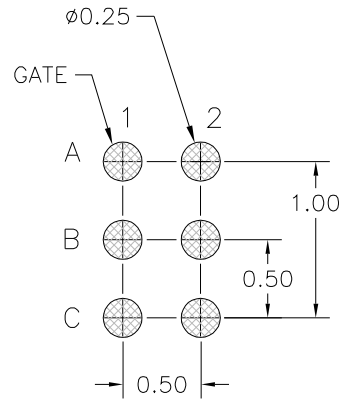
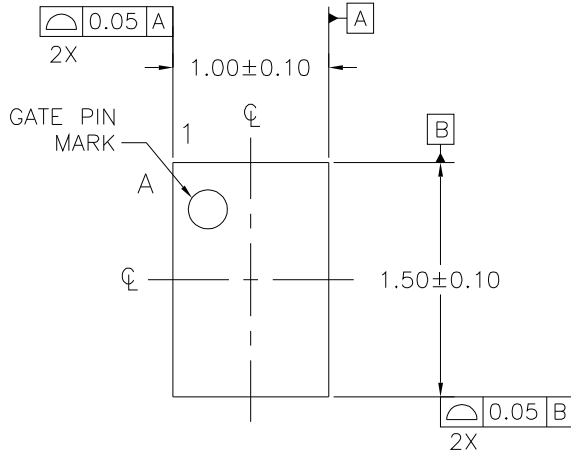

NOTES: UNLESS OTHERWISE SPECIFIED

- A) ALL DIMENSIONS ARE IN MILLIMETERS.
- B) NO JEDEC REGISTRATION REFERENCE AS OF OCTOBER 2005.
- C) TERMINAL CONFIGURATION TABLE.

POSITION	DESIGNATION
C1, C2	DRAIN
A1	GATE
A2, B1, B2	SOURCE

UC006AAREVB



TRADEMARKS

The following are registered and unregistered trademarks and service marks Fairchild Semiconductor owns or is authorized to use and is not intended to be an exhaustive list of all such trademarks.

ACEx®	Green FPS™	Power247®	SuperSOT™-8
Build it Now™	Green FPS™ e-Series™	POWEREDGE®	SyncFET™
CorePLUS™	GTO™	Power-SPM™	The Power Franchise®
CROSSVOLT™	i-Lo™	PowerTrench®	the power®
CTL™	IntelliMAX™	Programmable Active Droop™	franchise
Current Transfer Logic™	ISOPLANAR™	QFET®	TinyBoost™
EcoSPARK®	MegaBuck™	QS™	TinyBuck™
	MICROCOUPLER™	QT Optoelectronics™	TinyLogic®
Fairchild®	MicroFET™	Quiet Series™	TINYOPTO™
Fairchild Semiconductor®	MicroPak™	RapidConfigure™	TinyPower™
FACT Quiet Series™	MillerDrive™	SMART START™	TinyPWM™
FACT®	Motion-SPM™	SPM®	TinyWire™
FAST®	OPTOLOGIC®	STEALTH™	µSerDes™
FastvCore™	OPTOPLANAR®	SuperFET™	UHC®
FPST™		SuperSOT™-3	UniFET™
FRFET®	PDP-SPM™	SuperSOT™-6	VCX™
Global Power Resource SM	Power220®		

DISCLAIMER

FAIRCHILD SEMICONDUCTOR RESERVES THE RIGHT TO MAKE CHANGES WITHOUT FURTHER NOTICE TO ANY PRODUCTS HEREIN TO IMPROVE RELIABILITY, FUNCTION, OR DESIGN. FAIRCHILD DOES NOT ASSUME ANY LIABILITY ARISING OUT OF THE APPLICATION OR USE OF ANY PRODUCT OR CIRCUIT DESCRIBED HEREIN; NEITHER DOES IT CONVEY ANY LICENSE UNDER ITS PATENT RIGHTS, NOR THE RIGHTS OF OTHERS. THESE SPECIFICATIONS DO NOT EXPAND THE TERMS OF FAIRCHILD'S WORLDWIDE TERMS AND CONDITIONS, SPECIFICALLY THE WARRANTY THEREIN, WHICH COVERS THESE PRODUCTS.

LIFE SUPPORT POLICY

FAIRCHILD'S PRODUCTS ARE NOT AUTHORIZED FOR USE AS CRITICAL COMPONENTS IN LIFE SUPPORT DEVICES OR SYSTEMS WITHOUT THE EXPRESS WRITTEN APPROVAL OF FAIRCHILD SEMICONDUCTOR CORPORATION.

As used herein:

- Life support devices or systems are devices or systems which, (a) are intended for surgical implant into the body, or (b) support or sustain life, and (c) whose failure to perform when properly used in accordance with instructions for use provided in the labeling, can be reasonably expected to result in significant injury to the user.
- A critical component is any component of a life support device or system whose failure to perform can be reasonably expected to cause the failure of the life support device or system, or to affect its safety or effectiveness.

PRODUCT STATUS DEFINITIONS

Definition of Terms

Datasheet Identification	Product Status	Definition
Advance Information	Formative or In Design	This datasheet contains the design specifications for product development. Specifications may change in any manner without notice.
Preliminary	First Production	This datasheet contains preliminary data; supplementary data will be published at a later date. Fairchild Semiconductor reserves the right to make changes at any time without notice to improve design.
No Identification Needed	Full Production	This datasheet contains final specifications. Fairchild Semiconductor reserves the right to make changes at any time without notice to improve design.
Obsolete	Not In Production	This datasheet contains specifications on a product that has been discontinued by Fairchild semiconductor. The datasheet is printed for reference information only.

Rev. I31