

# SN55109A, SN55110A SN75109A, SN75110A, SN75112 DUAL LINE DRIVERS

SLLS106B - DECEMBER 1975 - REVISED MAY 1995

- Improved Stability Over Supply Voltage and Temperature Ranges
- Constant-Current Outputs
- High Speed
- Standard Supply Voltages
- High Output Impedance
- High Common-Mode Output Voltage Range  
-3 V to 10 V
- TTL-Input Compatibility
- Inhibitor Available for Driver Selection
- Glitch-Free During Power Up/Power Down
- SN75112 and External Circuit Meets or Exceeds the Requirements of CCITT Recommendation V.35

## description

The SN55109A, SN55110A, SN75109A, SN75110A, and SN75112 dual line drivers have improved output current regulation with supply voltage and temperature variations. In addition, the higher current of the SN75112 (27 mA) allows data to be transmitted over longer lines. These drivers offer optimum performance when used with the SN55107A, SN55108A, SN75107A, and SN75108A line receivers.

These drivers feature independent channels with common voltage supply and ground terminals. The significant difference between the three drivers is in the output current specification. The driver circuits feature a constant output current that is switched to either of two output terminals by the appropriate logic levels at the input terminals. The output current can be switched off (inhibited) by low logic levels on the enable inputs. The output current is nominally 6 mA for the '109A, 12 mA for the '110A, and 27 mA for the SN75112.

The enable/inhibit feature is provided so the circuits can be used in party-line or data-bus applications. A strobe or inhibitor (enable D), common to both drivers, is included for increased driver-logic versatility. The output current in the inhibited mode,  $I_{O(off)}$ , is specified so that minimum line loading is induced when the driver is used in a party-line system with other drivers. The output impedance of the driver in the inhibited mode is very high. The output impedance of a transistor is biased to cutoff.

SN55109A, SN55110A ... J OR W PACKAGE  
SN75109A, SN75110A, SN75112 ... D OR N PACKAGE

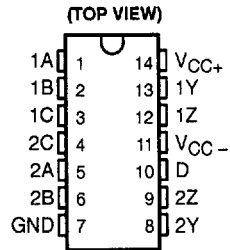

SN55109A, SN55110A ... FK PACKAGE  
(TOP VIEW)

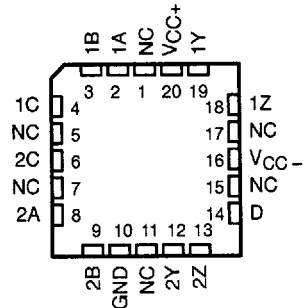

NC - No internal connection

**THE SN75109A IS NOT  
RECOMMENDED FOR NEW DESIGNS**

## AVAILABLE OPTIONS

T <sub>A</sub>	PACKAGED DEVICES				CERAMIC FLATPACK (W)
	SMALL OUTLINE (D)	CHIP CARRIER (FK)	CERAMIC DIP (J)	PLASTIC DIP (N)	
0°C to 70°C	SN75109AD SN75110AD SN75112D			SN75109AN SN75110AN SN75112N	
-55°C to 125°C		SN55109AFK SN55110AFK	SN55109AJ SN55110AJ	SN55109AJ SN55110AJ	SN55109AW SN55110AW

The D package is available taped and reeled. Add the suffix R to the device type, (e.g., SN75110ADR).

PRODUCTION DATA information is current as of publication date. Products conform to specifications per the terms of Texas Instruments standard warranty. Production processing does not necessarily include testing of all parameters.

**TEXAS  
INSTRUMENTS**

POST OFFICE BOX 655303 • DALLAS, TEXAS 75265

Copyright © 1995, Texas Instruments Incorporated

8961724 0098415 232

**SN55109A, SN55110A**  
**SN75109A, SN75110A, SN75112**  
**DUAL LINE DRIVERS**

SLLS106B - DECEMBER 1975 - REVISED MAY 1995

**description (continued)**

The driver outputs have a common-mode voltage range of -3 V to 10 V, allowing common-mode voltage on the line without affecting driver performance.

All inputs are diode clamped and are designed to satisfy TTL-system requirements. The inputs are tested at 2 V for high-logic-level input conditions and 0.8 V for low-logic-level input conditions. These tests ensure 400-mV noise margin when interfaced with TTL Series 54/74.

The SN55109A and SN55110A are characterized for operation over the full military temperature range of -55°C to 125°C. The SN75109A, SN75110A, and SN75112 are characterized for operation from 0°C to 70°C.

**FUNCTION TABLE**  
(each driver)

LOGIC INPUTS		ENABLE INPUTS		OUTPUTS†	
A	B	C	D	Y	Z
X	X	L	X	Off	Off
X	X	X	L	Off	Off
L	X	H	H	On	Off
X	L	H	H	On	Off
H	H	H	H	Off	On

H = high level, L = low level, X = irrelevant

† When using only one channel of the line drivers, the other channel should be inhibited and/or have its outputs grounded.

8961724 0098416 179

 **TEXAS  
INSTRUMENTS**

POST OFFICE BOX 655303 • DALLAS, TEXAS 75265

SN55109A, SN55110A  
 SN75109A, SN75110A, SN75112  
**DUAL LINE DRIVERS**  
 SLLS106B - DECEMBER 1975 - REVISED MAY 1995

schematic (each driver)

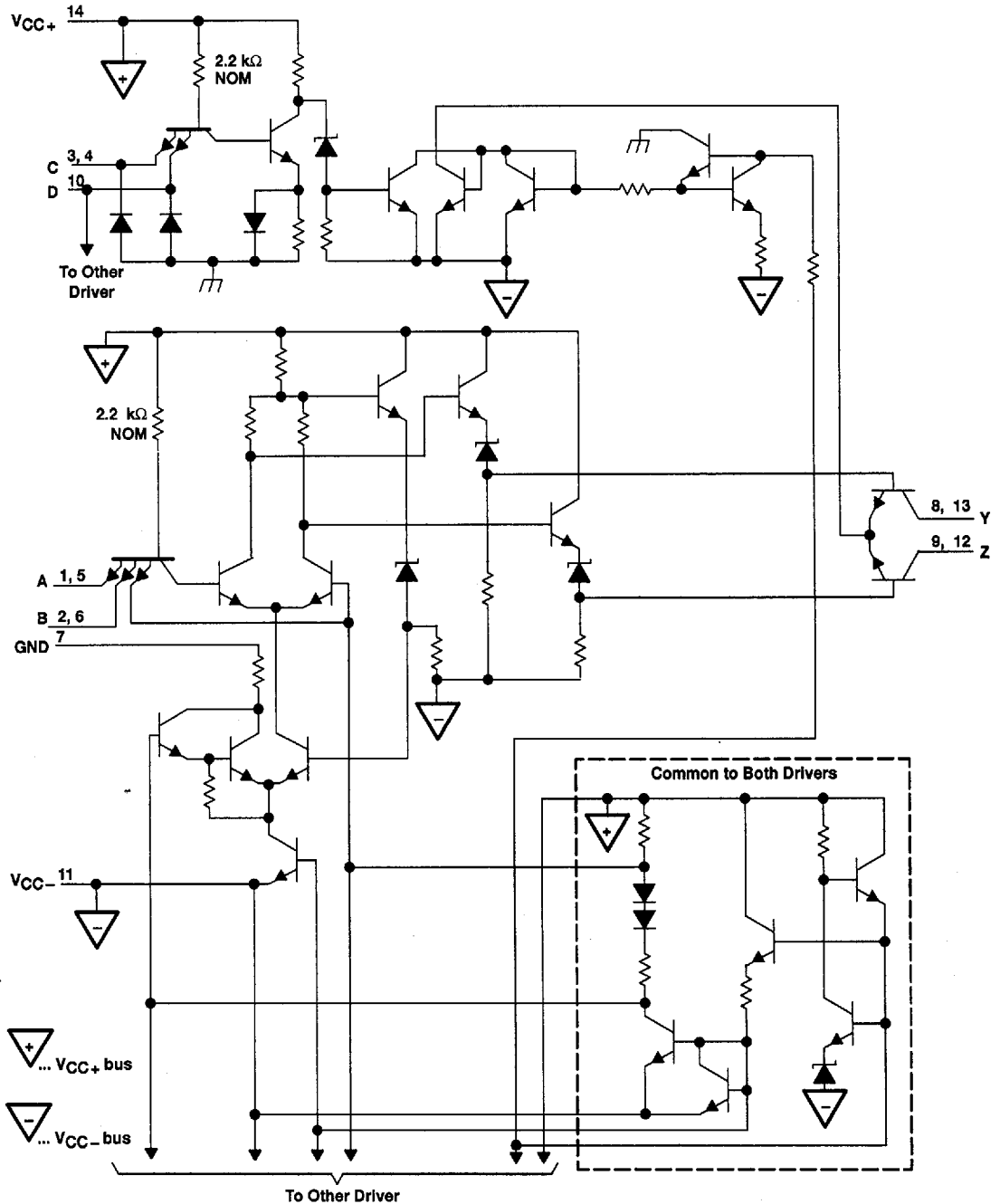

Pin numbers shown are for D, J, N, and W packages.

8961724 0098417 005

**TEXAS  
 INSTRUMENTS**

POST OFFICE BOX 655303 • DALLAS, TEXAS 75265

**SN55109A, SN55110A**  
**SN75109A, SN75110A, SN75112**  
**DUAL LINE DRIVERS**

SLLS106B - DECEMBER 1975 - REVISED MAY 1985

**absolute maximum ratings over operating free-air temperature range (unless otherwise noted)†**

	SN55109A SN55110A	SN75109A SN75110A	SN75112	UNIT	
Supply voltage, $V_{CC+}$ (see Note 1)	7	7	7	V	
Supply voltage, $V_{CC-}$	-7	-7	-7	V	
Input voltage, $V_I$	5.5	5.5	5.5	V	
Output voltage range, $V_O$	-5 to 12	-5 to 12	-5 to 12	V	
Continuous total power dissipation (see Note 2)	See Dissipation Rating Table				
Operating free-air temperature range, $T_A$	-55 to 125	0 to 70	0 to 70	°C	
Storage temperature range, $T_{stg}$	-65 to 150	-65 to 150	-65 to 150	°C	
Case temperature for 60 seconds: FK package	260			°C	
Lead temperature 1,6 mm (1/16 inch) from case for 60 seconds	J or W package	300		°C	
Lead temperature 1,6 mm (1/16 inch) from case for 10 seconds	D or N package		260	260	°C

† Stresses beyond those listed under "absolute maximum ratings" may cause permanent damage to the device. These are stress ratings only, and functional operation of the device at these or any other conditions beyond those indicated under "recommended operating conditions" is not implied. Exposure to absolute-maximum-rated conditions for extended periods may affect device reliability.

NOTES: 1. Voltage values are with respect to network ground terminal.

2. In the FK, J, or W package, SN55109A and SN55110A chips are either silver glass or alloy mounted, and SN75109A, SN75110A, and SN75112 chips are glass mounted.

**DISSIPATION RATING TABLE**

PACKAGE	$T_A \leq 25^\circ\text{C}$	DERATING FACTOR	$T_A = 70^\circ\text{C}$	$T_A = 125^\circ\text{C}$
	POWER RATING	ABOVE $T_A = 25^\circ\text{C}$	POWER RATING	POWER RATING
D	950 mW	7.6 mW/°C	608 mW	—
FK	1375 mW	11.0 mW/°C	880 mW	275 mW
J	1375 mW	11.0 mW/°C	880 mW	275 mW
N	1150 mW	9.2 mW/°C	736 mW	—
W	1000 mW	8.0 mW/°C	640 mW	200 mW

**recommended operating conditions (see Note 3)**

	SN55109A SN55110A			SN75109A SN75110A SN75112			UNIT
	MIN	NOM	MAX	MIN	NOM	MAX	
Supply voltage, $V_{CC+}$	4.5	5	5.5	4.75	5	5.25	V
Supply voltage, $V_{CC-}$	-4.5	-5	-5.5	-4.75	-5	-5.25	V
Positive common-mode output voltage	0		10	0		10	V
Negative common-mode output voltage	0		-3	0		-3	V
High-level input voltage, $V_{IH}$	2			2			V
Low-level output current, $V_{IL}$			0.8			0.8	V
Operating free-air temperature, $T_A$	-55		125	0		70	°C

NOTE 3: When using only one channel of the line drivers, the other channel should be inhibited and/or have its outputs grounded.

8961724 0098418 T41



POST OFFICE BOX 655303 • DALLAS, TEXAS 75265

electrical characteristics over recommended operating free-air temperature range (unless otherwise noted)

PARAMETER	TEST CONDITION†	SN55109A SN75109A		SN55110A SN75110A		SN75112		UNIT			
		MIN	TYP‡	MAX	MIN	TYP‡	MAX		MIN	TYP‡	MAX
V <sub>IK</sub> Input clamp voltage	V <sub>CC±</sub> = MIN, I <sub>L</sub> = -12 mA	-0.9		-1.5	6	7	-0.9	-1.5	27	36	V
	V <sub>CC±</sub> = MAX, V <sub>O</sub> = 10 V										
I <sub>O</sub> (on) On-state output current	V <sub>CC±</sub> = MIN to MAX, V <sub>O</sub> = -1 V to 1 V, T <sub>A</sub> = 25°C						24	28	32		mA
	V <sub>CC±</sub> = MIN, V <sub>O</sub> = -3 V	3.5	6								
I <sub>O</sub> (off) Off-state output current	V <sub>CC±</sub> = MIN, V <sub>O</sub> = 10 V			100			18	27			µA
	Input current at maximum input voltage			1							1
I <sub>I</sub> High-level input current	A, B, or C inputs			2							2
	D input										
I <sub>IH</sub> High-level input current	A, B, or C inputs			40							40
	D input			80							80
I <sub>IL</sub> Low-level input current	A, B, or C inputs			-3							-3
	D input			-6							-6
I <sub>CC</sub> + (on) Supply current from V <sub>CC</sub> + with driver enabled	V <sub>CC±</sub> = MAX, A and B inputs at 0.4 V, C and D inputs at 2 V			18	30	30	23	35	25	40	mA
	V <sub>CC±</sub> = MAX, A, B, C, and D inputs at 0.4 V			-18	-30	-30	-34	-50	-65	-100	
I <sub>CC</sub> - (off) Supply current from V <sub>CC</sub> - with driver inhibited	V <sub>CC±</sub> = MAX, A, B, C, and D inputs at 0.4 V			18			21		30		mA
	V <sub>CC±</sub> = MAX, A, B, C, and D inputs at 0.4 V			-10			-17		-32		

† For conditions shown as MIN or MAX, use appropriate value specified under recommended operating conditions.  
 ‡ All typical values are at V<sub>CC+</sub> = 5 V, V<sub>CC-</sub> = -5 V, T<sub>A</sub> = 25°C.

**SN55109A, SN55110A**  
**SN75109A, SN75110A, SN75112**  
**DUAL LINE DRIVERS**

SLLS106B - DECEMBER 1975 - REVISED MAY 1995

switching characteristics,  $V_{CC\pm} = \pm 5\text{ V}$ ,  $T_A = 25^\circ\text{C}$

PARAMETER†	FROM (INPUT)	TO (OUTPUT)	TEST CONDITIONS	MIN	TYP	MAX	UNIT
$t_{PLH}$	A or B	Y or Z	$C_L = 40\text{ pF}$ , $R_L = 50\ \Omega$ , See Figure 1		9	15	ns
$t_{PHL}$					9	15	ns
$t_{PLH}$	C or D	Y or Z			16	25	ns
$t_{PHL}$					13	25	ns

†  $t_{PLH}$  = Propagation delay time, low-to-high-level output  
 $t_{PHL}$  = Propagation delay time, high-to-low-level output

**PARAMETER MEASUREMENT INFORMATION**

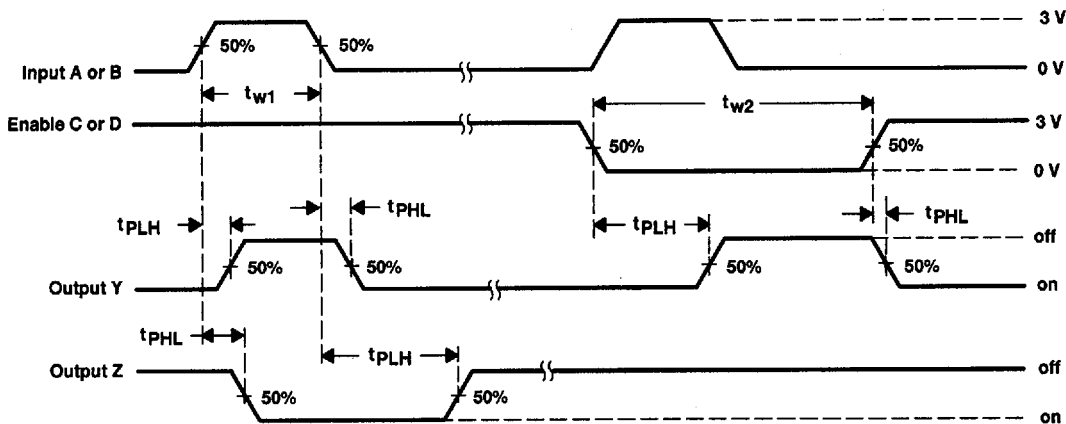
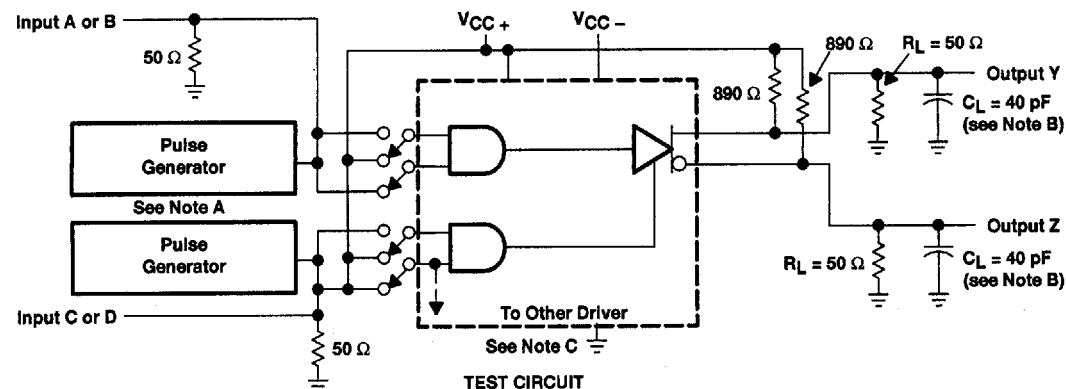

**VOLTAGE WAVEFORMS**

- NOTES: A. The pulse generators have the following characteristics:  $Z_0 = 50\ \Omega$ ,  $t_r = t_f = 10 \pm 5\text{ ns}$ ,  $t_{w1} = 500\text{ ns}$ ,  $PRR \leq 1\text{ MHz}$ ,  $t_{w2} = 1\ \mu\text{s}$ ,  $PRR \leq 500\text{ kHz}$ .  
 B.  $C_L$  includes probe and jig capacitance.  
 C. For simplicity, only one channel and the enable connections are shown.

**Figure 1. Test Circuit and Voltage Waveforms**

TYPICAL CHARACTERISTICS

SN55109A, SN75109A  
 ON-STATE OUTPUT CURRENT  
 VS  
 NEGATIVE SUPPLY VOLTAGE

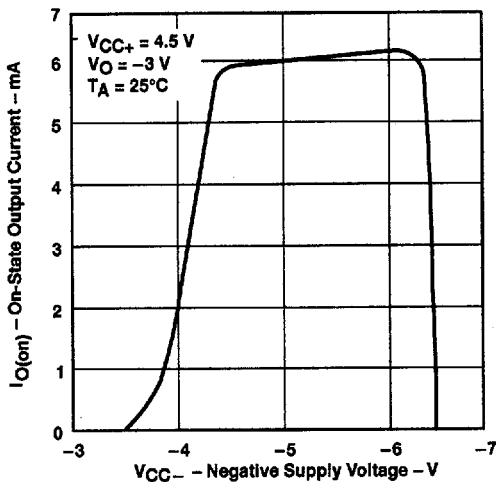

Figure 2

SN55110A, SN75110A  
 ON-STATE OUTPUT CURRENT  
 VS  
 NEGATIVE SUPPLY VOLTAGE

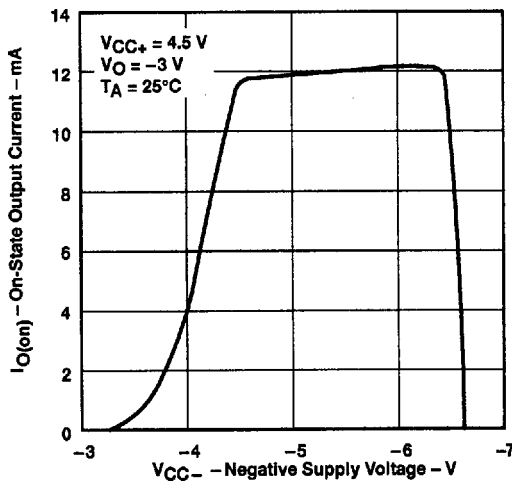

Figure 3

SN75112  
 ON-STATE OUTPUT CURRENT  
 VS  
 NEGATIVE SUPPLY VOLTAGE

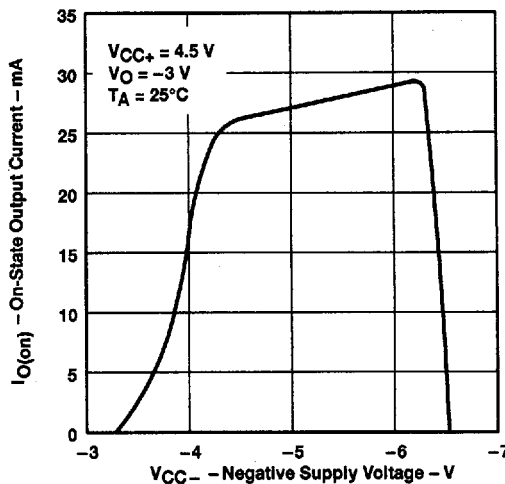

Figure 4

**SN55109A, SN55110A  
SN75109A, SN75110A, SN75112  
DUAL LINE DRIVERS**  
SLLS106B - DECEMBER 1975 - REVISED MAY 1995

**APPLICATION INFORMATION**

**special pulse-control circuit**

Figure 5 shows a circuit that may be used as a pulse generator output or in many other testing applications.

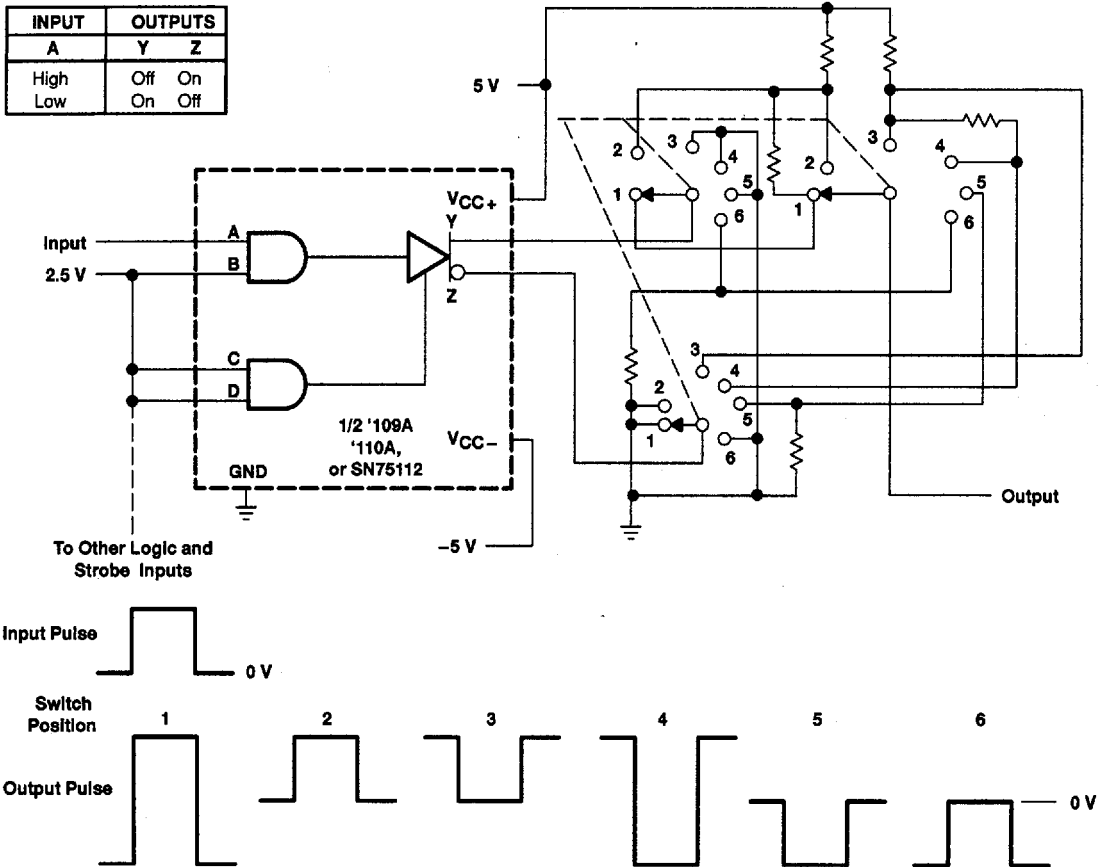

**Figure 5. Pulse-Control Circuit**



APPLICATION INFORMATION

using the SN75112 as a CCITT recommended V.35 line driver

The SN75112 dual line driver, the SN75107A dual line receiver, and some external resistors can be used to implement the data interchange circuit of CCITT recommendation V.35 (1976) modem specification. The circuit of one channel is shown in Figure 1 and meets the requirement of the interface as specified by Appendix 11 of CCITT V.35 and summarized in Table 1 (V.35 has been replaced by ITU V.11).

Table 1. CCITT V.35 Electrical Requirements

	MIN	MAX	UNIT
<b>GENERATOR</b>			
Source impedance, $Z_{source}$	50	150	$\Omega$
Resistance to ground, R	135	165	$\Omega$
Differential output voltage, $V_{OD}$	440	660	mV
10% to 90% rise time, $t_r$	40		ns
or		$0.01 \times ui^\dagger$	
Common-mode output voltage, $V_{OC}$	-0.6	0.6	V
<b>LOAD (RECEIVER)</b>			
Input impedance, $Z_I$	90	110	$\Omega$
Resistance to ground, R	135	165	$\Omega$

$^\dagger ui$  = unit interval or minimum signal element pulse width

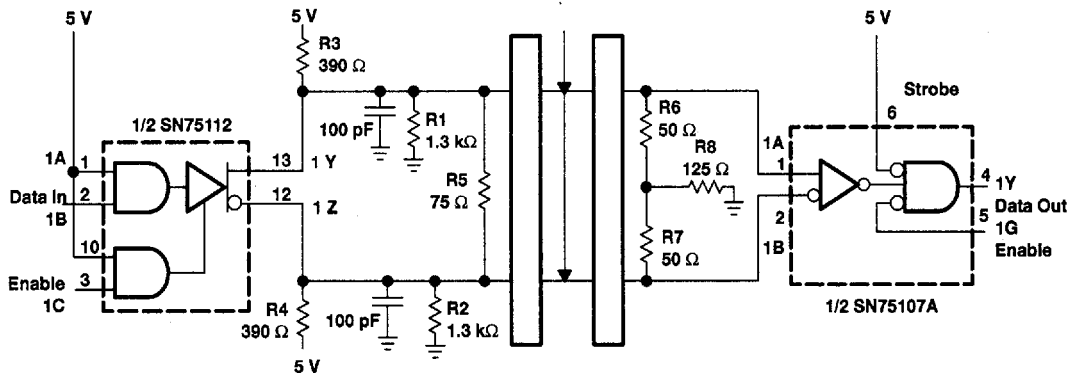

All resistors are 5%, 1/4 W.

Figure 6. CCITT Recommended V.35 Interface Using the SN75112 and SN75107A

8961724 0098423 309