

4-1/2 Digit A/D Converter

Features

- Low Rollover Error: ± 1 Count Max
- Nonlinearity Error: ± 1 Count Max
- Reading for 0V Input
- True Polarity Indication at Zero for Null Detection
- Multiplexed BCD Data Output
- TTL-Compatible Outputs
- Differential Input
- Control Signals Permit Interface to UARTs and Microprocessors
- Blinking Display Visually Indicates Overrange Condition
- Low Input Current: 1 pA
- Low Zero Reading Drift: $2 \mu\text{V}/^\circ\text{C}$
- Auto-Ranging Supported with Overrange and Underrange Signals
- Available in PDIP and Surface-Mount Packages

General Description

The TC7135 4-1/2 digit A/D Converter (ADC) offers 50 ppm (1 part in 20,000) resolution with a maximum nonlinearity error of 1 count. An auto-zero cycle reduces zero error to below $10 \mu\text{V}$ and zero drift to $0.5 \mu\text{V}/^\circ\text{C}$. Source impedance errors are minimized by a 10 pA maximum input current. Rollover error is limited to ± 1 count.

Microprocessor-based measurement systems are supported by the BUSY, STROBE and RUN/HOLD control signals. Remote data acquisition systems with data transfer via UARTs are also possible. The additional control pins and multiplexed BCD outputs make the TC7135 the ideal converter for display or microprocessor-based measurement systems.

Applications

- Precision Analog Signal Processor
- Precision Sensor Interface
- High Accuracy DC Measurements

Functional Block Diagram

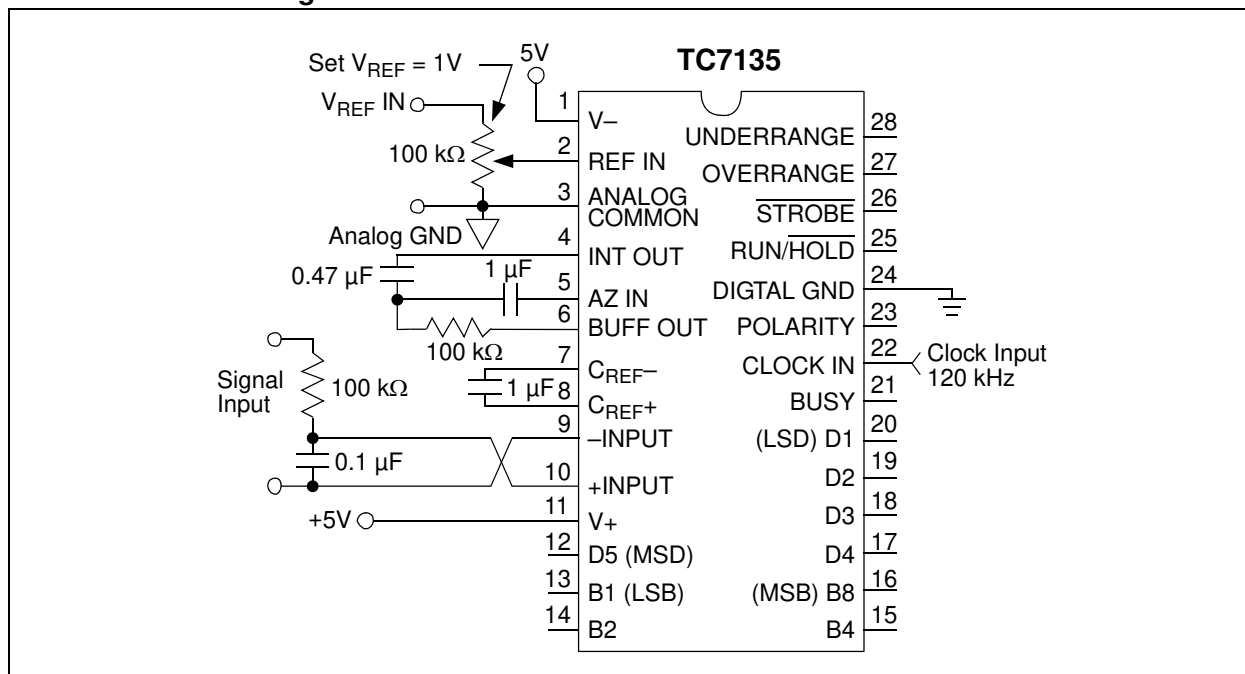

TC7135

Package Types

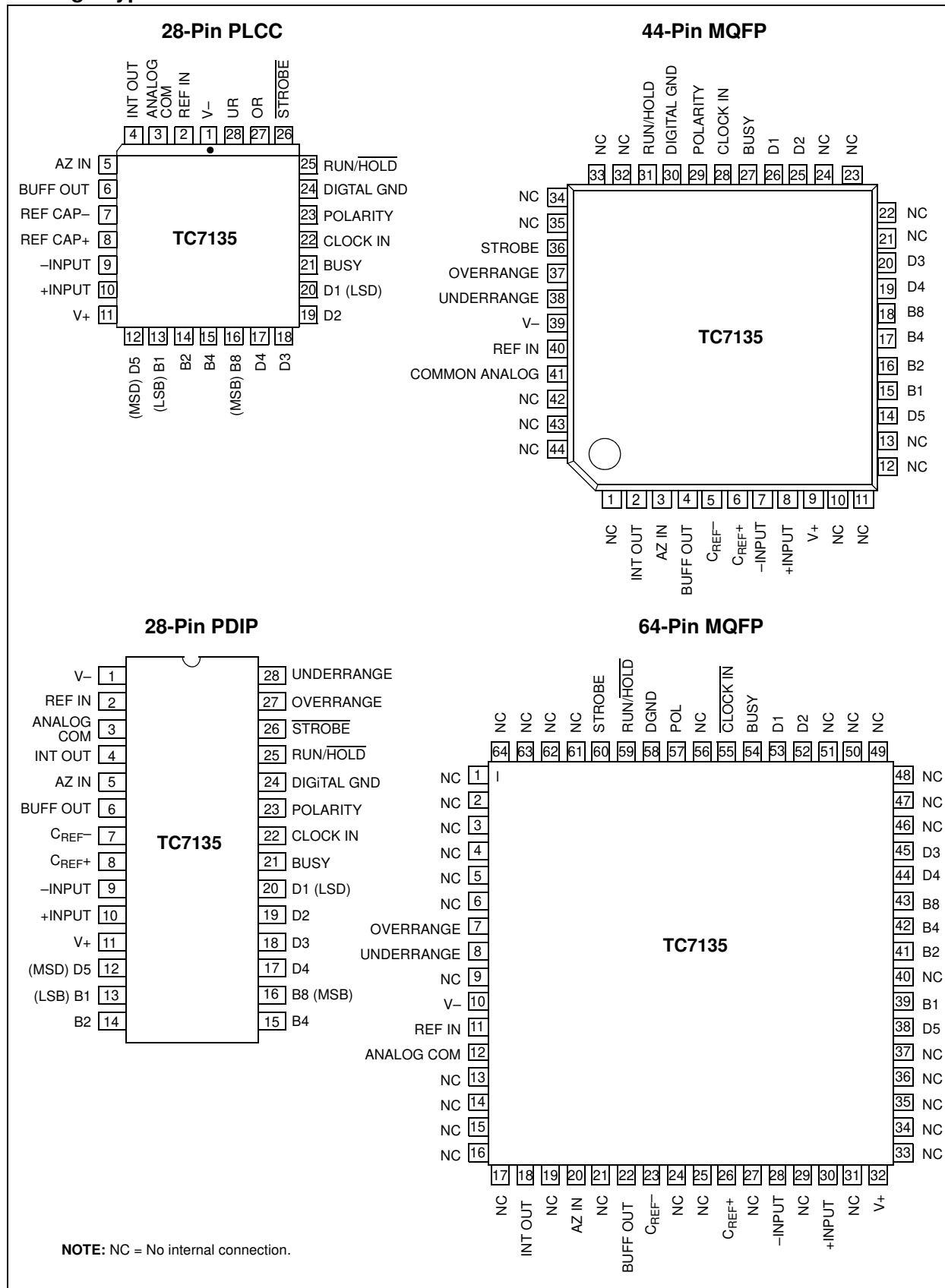

1.0 ELECTRICAL SPECIFICATIONS

Absolute Maximum Ratings†

Positive Supply Voltage.....	+6V
Negative Supply Voltage.....	- 9V
Analog Input Voltage (Pin 9 or 10).....	V+ to V- (Note 2)
Reference Input Voltage (Pin 2).....	V+ to V-
Clock Input Voltage	0V to V+
Operating Temperature Range	0°C to +70°C
Storage Temperature Range	-65°C to +150°C
Package Power Dissipation; ($T_A \leq 70^\circ\text{C}$)	
28-Pin PDIP	1.14Ω
28-Pin PLCC	1.00Ω
44-Pin MQFP.....	
64-Pin MQFP	1.14Ω

† **Notice:** Stresses above those listed under "Absolute Maximum Ratings" may cause permanent damage to the device. These are stress ratings only and functional operation of the device at these or any other conditions above those indicated in the operation sections of the specifications is not implied. Exposure to Absolute Maximum Rating conditions for extended periods may affect device reliability.

DC CHARACTERISTICS

Electrical Specifications: Unless otherwise indicated, $T_A = +25^\circ\text{C}$, $F_{\text{CLOCK}} = 120 \text{ kHz}$, $V_+ = +5\text{V}$, $V_- = -5\text{V}$. (see Functional Block Diagram).						
Parameters	Sym	Min.	Typ.	Max.	Units	Conditions
Analog						
Display Reading with Zero Volt Input		-0.0000	± 0.0000	+0.0000	Display Reading	Note 2, Note 3
Zero Reading Temperature Coefficient	TC_Z	—	0.5	2	$\mu\text{V}/^\circ\text{C}$	$V_{\text{IN}} = 0\text{V}$, (Note 4)
Full Scale Temperature Coefficient	TC_{FS}	—	—	5	ppm/ $^\circ\text{C}$	$V_{\text{IN}} = 2\text{V}$, (Note 4, Note 5)
Nonlinearity Error	NL	—	0.5	1	Count	Note 6
Differential Linearity Error	DNL	—	0.01	—	LSB	Note 6
Display Reading in Ratiometric Operation		+0.9995	+0.9999	+1.0000	Display Reading	$V_{\text{IN}} = V_{\text{REF}}$, (Note 2)
\pm Full Scale Symmetry Error (Rollover Error)	$\pm\text{FSE}$	—	0.5	1	Count	$-V_{\text{IN}} = +V_{\text{IN}}$, (Note 7)
Input Leakage Current	I_{IN}	—	1	10	μA	Note 3
Noise	e_N	—	15	—	$\mu\text{V}_{\text{P-P}}$	Peak-to-Peak Value not Exceeded 95% of Time
Digital						
Input Low Current	I_{IL}	—	10	100	μA	$V_{\text{IN}} = 0\text{V}$
Input High Current	I_{IH}	—	0.08	10	μA	$V_{\text{IN}} = +5\text{V}$
Output Low Voltage	V_{OL}	—	0.2	0.4	V	$I_{\text{OL}} = 1.6 \text{ mA}$
Output High Voltage;	V_{OH}	2.4	4.4	5	V	$I_{\text{OH}} = 1 \text{ mA}$
B ₁ , B ₂ , B ₄ , B ₈ , D ₁ ..D ₅ Busy, Polarity, Overrange, Underrange, Strobe		4.9	4.99	5	V	$I_{\text{OH}} = 10 \mu\text{A}$
Clock Frequency	F_{CLK}	0	200	1200	kHz	Note 8

- Note 1:** Limit input current to under 100 μA if input voltages exceed supply voltage.
Note 2: Full-scale voltage = 2V
Note 3: $V_{\text{IN}} = 0\text{V}$
Note 4: $30^\circ\text{C} \leq T_A \leq +70^\circ\text{C}$
Note 5: External reference temperature coefficient less than 0.01 ppm/ $^\circ\text{C}$.
Note 6: $-2\text{V} \leq V_{\text{IN}} \leq +2\text{V}$. Error of reading from best fit straight line.
Note 7: $|V_{\text{IN}}| = 1.9959$
Note 8: Specification related to clock frequency range over which the TC7135 correctly performs its various functions. Increased errors result at higher operating frequencies.

TC7135

DC CHARACTERISTICS (CONTINUED)

Electrical Specifications: Unless otherwise indicated, $T_A = +25^\circ\text{C}$, $F_{\text{CLOCK}} = 120 \text{ kHz}$, $V_+ = +5\text{V}$, $V_- = -5\text{V}$.
(see **Functional Block Diagram**).

Parameters	Sym	Min.	Typ.	Max.	Units	Conditions
Power Supply						
Positive Supply Voltage	V+	4	5	6	V	
Negative Supply Voltage	V-	-3	-5	-8	V	
Positive Supply Current	I+	—	1	3	mA	$F_{\text{CLK}} = 0 \text{ Hz}$
Negative Supply Current	I-	—	0.7	3	mA	$F_{\text{CLK}} = 0 \text{ Hz}$
Power Dissipation	PD	—	8.5	30	mW	$F_{\text{CLK}} = 0 \text{ Hz}$

- Note**
- 1: Limit input current to under $100 \mu\text{A}$ if input voltages exceed supply voltage.
 - 2: Full-scale voltage = 2V
 - 3: $V_{\text{IN}} = 0\text{V}$
 - 4: $30^\circ\text{C} \leq T_A \leq +70^\circ\text{C}$
 - 5: External reference temperature coefficient less than $0.01 \text{ ppm}/^\circ\text{C}$.
 - 6: $-2\text{V} \leq V_{\text{IN}} \leq +2\text{V}$. Error of reading from best fit straight line.
 - 7: $|V_{\text{IN}}| = 1.9959$
 - 8: Specification related to clock frequency range over which the TC7135 correctly performs its various functions. Increased errors result at higher operating frequencies.

2.0 PIN DESCRIPTIONS

The description of the pins are listed in [Table 2-1](#).

TABLE 2-1: PIN FUNCTION TABLE

Pin Number 28-Pin PDIP, 28-Pin PLCC	Pin Number 44-Pin MQFP*	Pin Number 64-Pin MQFP*	Symbol	Description
1	39	10	V ₋	Negative power supply input.
2	40	11	REF IN	External reference input.
3	41	12	ANALOG COMMON	Reference point for REF IN.
4	2	18	INT OUT	Integrator output. Integrator capacitor connection.
5	3	20	AZ IN	Auto-zero inpt. Auto-zero capacitor connection.
6	4	22	BUFF OUT	Analog input buffer output. Integrator resistor connection.
7	5	23	C _{REF-}	Reference capacitor input. Reference capacitor negative connection.
8	6	26	C _{REF+}	Reference capacitor input. Reference capacitor positive connection.
9	7	28	-INPUT	Analog input. Analog input negative connection.
10	8	30	+INPUT	Analog input. Analog input positive connection.
11	9	32	V ₊	Positive power supply input.
12	14	38	D5	Digit drive output. Most Significant Digit (MSD)
13	15	39	B1	Binary Coded Decimal (BCD) output. Least Significant bit (LSb).
14	16	41	B2	BCD output.
15	17	42	B4	BCD output.
16	18	43	B8	BCD output. Most Significant bit (MSb).
17	19	44	D4	Digit drive output.
18	20	45	D3	Digit drive output.
19	25	52	D2	Digit drive output.
20	26	53	D1	Digit drive output. Least Significant Digit (LSD).
21	27	54	BUSY	Busy output. At the beginning of the signal-integration phase, BUSY goes high and remains high until the first clock pulse after the integrator zero crossing.
22	28	55	CLOCK IN	Clock input. Conversion clock connection.
23	29	57	POLARITY	Polarity output. A positive input is indicated by a logic high output. The polarity output is valid at the beginning of the reference integrate phase and remains valid until determined during the next conversion.
24	30	58	DGND	Digital logic reference input.
25	31	59	RUN/HOLD	Run/Hold input. When at a logic high, conversions are performed continuously. A logic low holds the current data as long as the low condition exists.
26	36	60	STROBE	Strobe output. The STROBE output pulses low in the center of the digit drive outputs.
27	37	7	OVERRANGE	Overrange output. A logic high indicates that the analog input exceeds the full-scale input range.
28	38	8	UNDERRANGE	Underrange output. A logic high indicates that the analog input is less than 9% of the full-scale input range.

* Pins not identified or documented are NC (no connects).

TC7135

3.0 DETAILED DESCRIPTION

All pin designations refer to the 28-pin PDIP package.

3.1 Dual-Slope Conversion Principles

The TC7135 is a dual-slope, integrating A/D converter. An understanding of the dual-slope conversion technique will aid in following the detailed TC7135 operational theory.

The conventional dual-slope converter measurement cycle has two distinct phases:

1. Input signal integration.
2. Reference voltage integration (de-integration).

The input signal being converted is integrated for a fixed time period. Time is measured by counting clock pulses. An opposite polarity constant reference voltage is then integrated until the integrator output voltage returns to zero. The reference integration time is directly proportional to the input signal.

In a simple dual-slope converter, a complete conversion requires the integrator output to “ramp-up” and “ramp-down”.

A simple mathematical equation relates the input signal, reference voltage and integration time:

EQUATION 3-1:

$$\frac{1}{R_{INT}C_{INT}} \int_0^{T_{INT}} V_{IN}(T)DT = \frac{V_{REF}T_{DEINT}}{R_{INT}C_{INT}}$$

Where:

- V_{REF} = Reference voltage
- T_{INT} = Signal integration time (fixed)
- T_{DEINT} = Reference voltage integration time (variable)

For a constant V_{IN} :

EQUATION 3-2:

$$V_{IN} = \frac{V_{REF}T_{DEINT}}{T_{INT}}$$

The dual-slope converter accuracy is unrelated to the integrating resistor and capacitor values, as long as they are stable during a measurement cycle. An inherent benefit is noise immunity. Noise spikes are integrated, or averaged, to zero during the integration periods.

Integrated ADCs are immune to the large conversion errors that plague successive approximation converters in high-noise environments (see [Figure 3-1](#)).

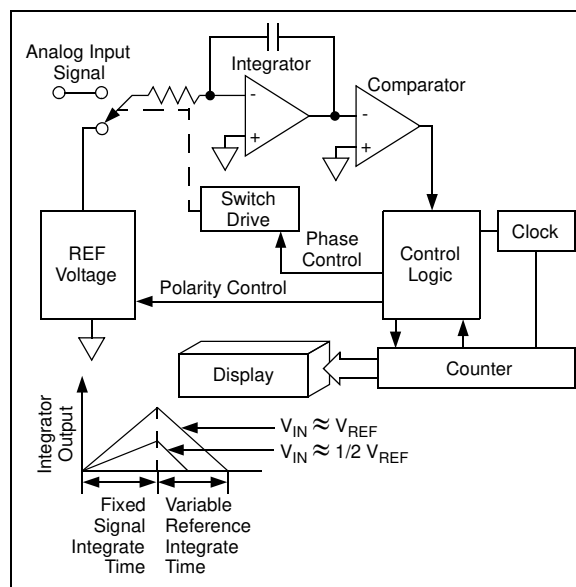

FIGURE 3-1: Basic Dual-Slope Converter.

3.2 Operational Theory

The TC7135 incorporates a system zero phase and integrator output voltage zero phase to the normal two-phase dual-slope measurement cycle. Reduced system errors, fewer calibration steps and a shorter overrange recovery time result.

The TC7135 measurement cycle contains four phases:

1. System zero.
2. Analog input signal integration.
3. Reference voltage integration.
4. Integrator output zero.

Internal analog gate status for each phase is shown in [Figure 3-1](#).

TABLE 3-1: INTERNAL ANALOG GATE STATUS

Conversion Cycle Phase	SW _I	SW _{RI+}	SW _{RI-}	SW _Z	SW _R	SW ₁	SW _{IZ}	Reference Figures
System Zero	—	—	—	Closed	Closed	Closed	—	Figure 3-2
Input Signal Integration	Closed	—	—	—	—	—	—	Figure 3-3
Reference Voltage Integration	—	Closed*	—	—	—	Closed	—	Figure 3-4
Integrator Output Zero	—	—	—	—	—	Closed	Closed	Figure 3-5

* Assumes a positive polarity input signal. SW_{RI} would be closed for a negative input signal.

3.2.1 SYSTEM ZERO

During this phase, errors due to buffer, integrator and comparator offset voltages are compensated for by charging C_{AZ} (auto-zero capacitor) with a compensating error voltage. With a zero input voltage, the integrator output will remain at zero.

The external input signal is disconnected from the internal circuitry by opening the two SW_1 switches. The internal input points connect to the ANALOG COMMON pin. The reference capacitor charges to the reference voltage potential through SW_R . A feedback loop, closed around the integrator and comparator, charges the C_{AZ} capacitor with a voltage to compensate for buffer amplifier, integrator and comparator offset voltages (see Figure 3-2).

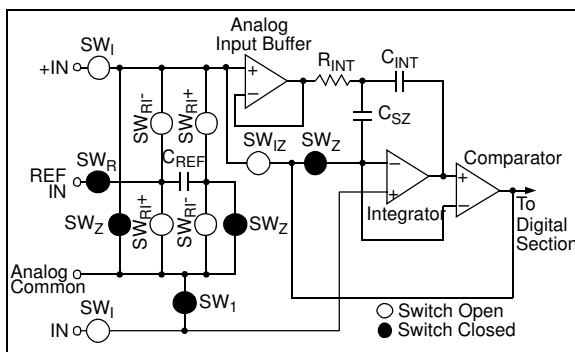

FIGURE 3-2: System Zero Phase.

3.2.2 ANALOG INPUT SIGNAL INTEGRATION

The TC7135 integrates the differential voltage between the +INPUT and -INPUT pins. The differential voltage must be within the device Common mode range; -1V from either supply rail, typically. The input signal polarity is determined at the end of this phase.

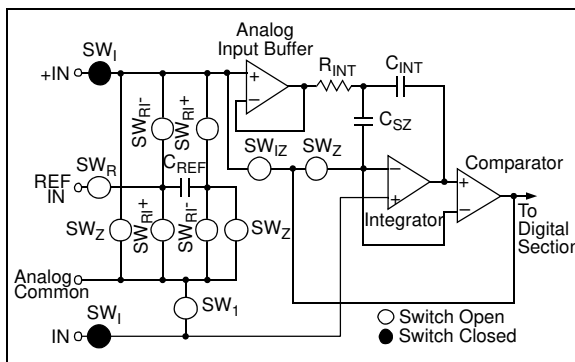

FIGURE 3-3: Input Signal Integration Phase.

3.2.3 REFERENCE VOLTAGE INTEGRATION

The previously charged reference capacitor is connected with the proper polarity to ramp the integrator output back to zero (see Figure 3-4). The digital reading displayed is:

EQUATION 3-3:

$$Reading = 10,000 \frac{[Differential\ Input]}{V_{REF}}$$

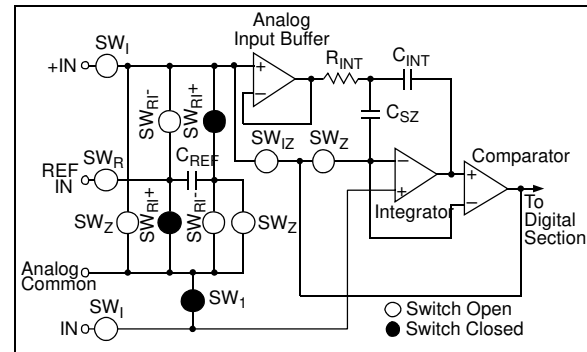

FIGURE 3-4: Reference Voltage Integration Cycle.

3.2.4 INTEGRATOR OUTPUT ZERO

This phase ensures the integrator output is at 0V when the system zero phase is entered. It also ensures that the true system offset voltages are compensated for. This phase normally lasts 100 to 200 clock cycles. If an overrange condition exists, the phase is extended to 6200 clock cycles (see Figure 3-5).

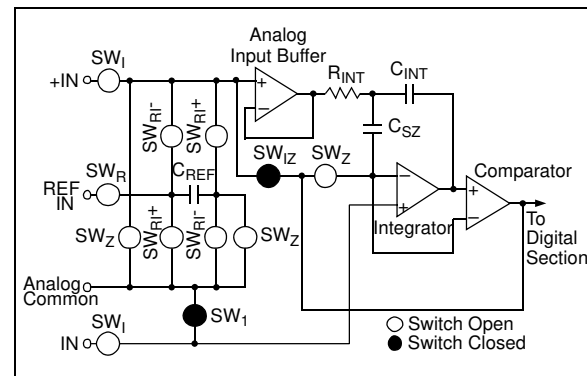

FIGURE 3-5: Integrator Output Zero Phase.

TC7135

4.0 ANALOG SECTION FUNCTIONAL DESCRIPTION

4.1 Differential Inputs

The TC7135 operates with differential voltages (+INPUT, pin 10 and -INPUT, pin 9) within the input amplifier Common mode range, which extends from 1V below the positive supply to 1V above the negative supply. Within this Common mode voltage range, an 86 dB Common mode rejection ratio is typical.

The integrator output also follows the Common mode voltage and must not be allowed to saturate. A worst-case condition exists, for example, when a large positive Common mode voltage with a near full scale negative differential input voltage is applied. The negative input signal drives the integrator positive when most of its swing has been used up by the positive Common mode voltage. For these critical applications, the integrator swing can be reduced to less than the recommended 4V full scale swing, resulting in some loss of accuracy. The integrator output can swing within 0.3V of either supply without loss of linearity.

4.2 Analog Common Input

The ANALOG COMMON pin is used as the -INPUT return during auto-zero and de-integrate. If -INPUT is different from ANALOG COMMON, a Common mode voltage exists in the system. However, this signal is rejected by the excellent CMRR of the converter. In most applications, -INPUT will be set at a fixed, known voltage (power supply common, for instance). In this application, ANALOG COMMON should be tied to the same point, thus removing the Common mode voltage from the converter. The reference voltage is referenced to ANALOG COMMON.

4.3 Reference Voltage Input

The reference voltage input (REF IN) must be a positive voltage with respect to ANALOG COMMON. A reference voltage circuit is shown in Figure 4-1.

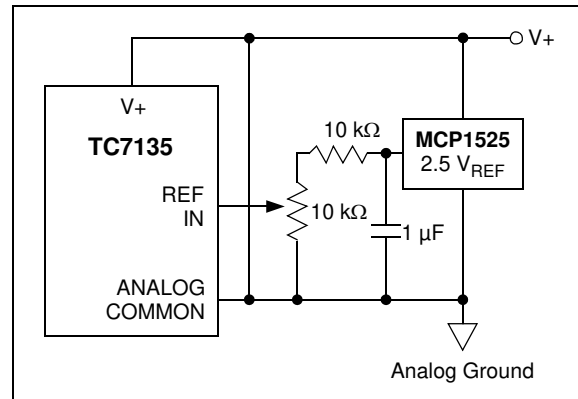

FIGURE 4-1: Using An External Reference.

5.0 DIGITAL SECTION FUNCTIONAL DESCRIPTION

The major digital subsystems within the TC7135 are illustrated in Figure 5-1, with timing relationships shown in Figure 5-2. The multiplexed BCD output data can be displayed on LCD or LED displays. The digital section is best described through a discussion of the control signals and data outputs.

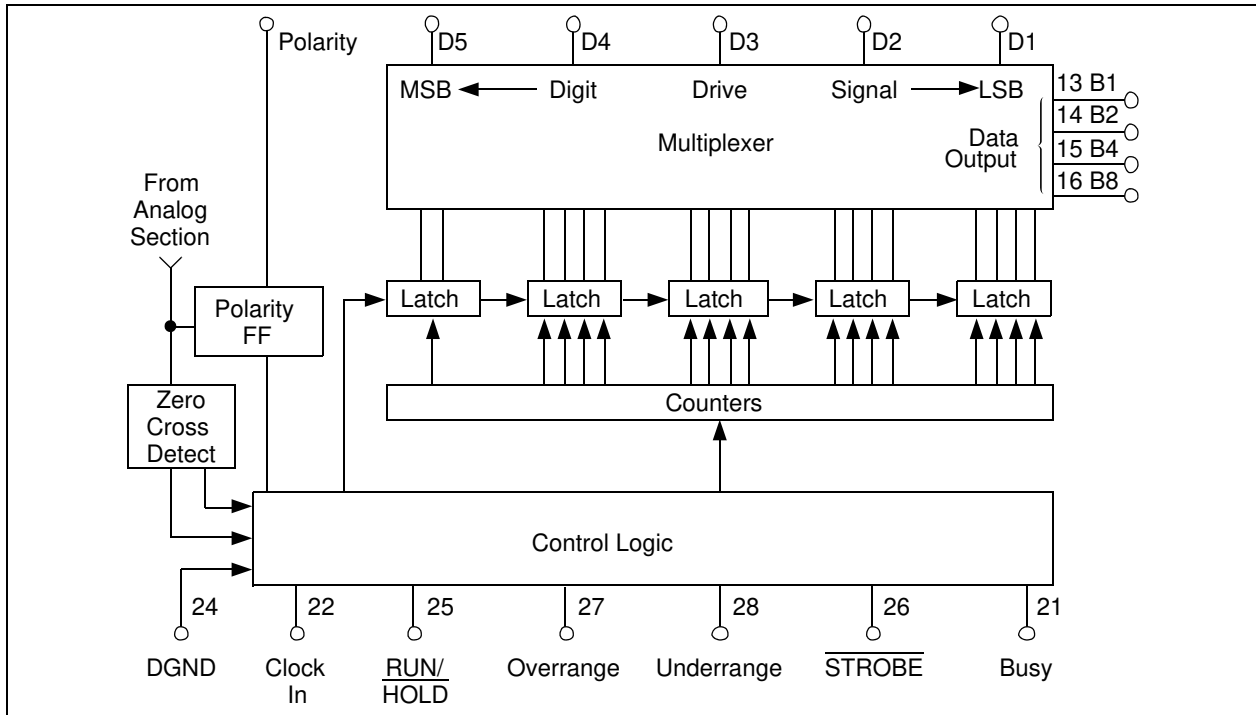

FIGURE 5-1: Digital Section Functional Diagram.

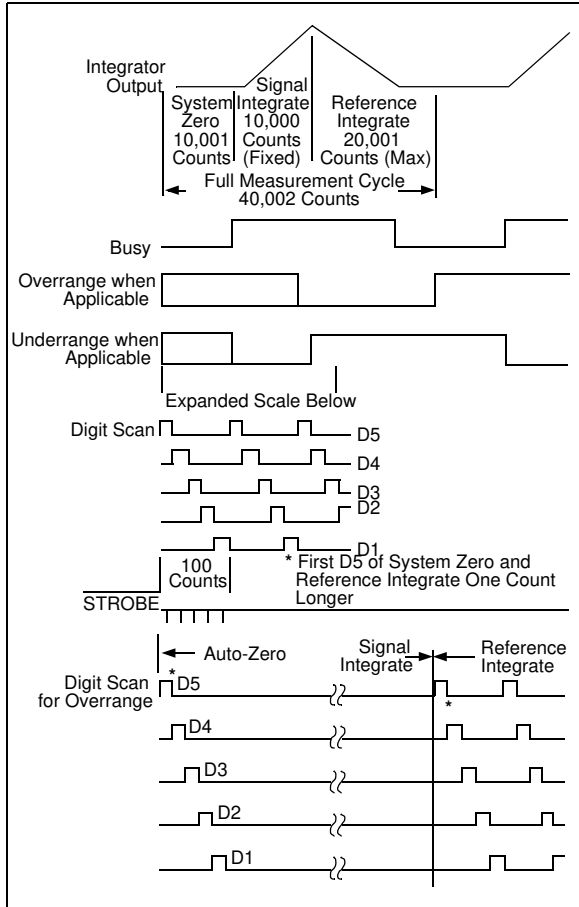

FIGURE 5-2: Timing Diagrams For Outputs.

5.1 RUN/HOLD Input

When left open, this pin assumes a logic '1' level. With a $\text{RUN/HOLD} = 1$, the TC7135 performs conversions continuously, with a new measurement cycle beginning every 40,002 clock pulses.

When RUN/HOLD changes to a logic '0', the measurement cycle in progress will be completed, with the data held and displayed as long as the logic '0' condition exists.

A positive pulse (>300 nsec) at RUN/HOLD initiates a new measurement cycle. The measurement cycle in progress when RUN/HOLD initially assumed the logic '0' state must be completed before the positive pulse can be recognized as a single conversion run command.

The new measurement cycle begins with a 10,001 count auto-zero phase. At the end of this phase, the busy signal goes high.

5.2 STROBE Output

During the measurement cycle, the $\overline{\text{STROBE}}$ control line is pulsed low five times. The five low pulses occur in the center of the digit drive signals (D_1, D_2, D_3, D_4, D_5) (see Figure 5-3).

D_5 (MSD) goes high for 201 counts when the measurement cycles end. In the center of the D_5 pulse, 101 clock pulses after the end of the measurement cycle, the first $\overline{\text{STROBE}}$ occurs for one half clock pulse. After the D_5 digit strobe, D_4 goes high for 200 clock pulses. The $\overline{\text{STROBE}}$ then goes low 100 clock pulses after D_4 goes high. This continues through the D_1 digit drive pulse.

The digit drive signals will continue to permit display scanning. $\overline{\text{STROBE}}$ pulses are not repeated until a new measurement is completed. The digit drive signals will not continue if the previous signal resulted in an overrange condition.

The active-low $\overline{\text{STROBE}}$ pulses aid BCD data transfer to UARTs, processors and external latches. For more information, please refer to Application Note 784 (DS00784).

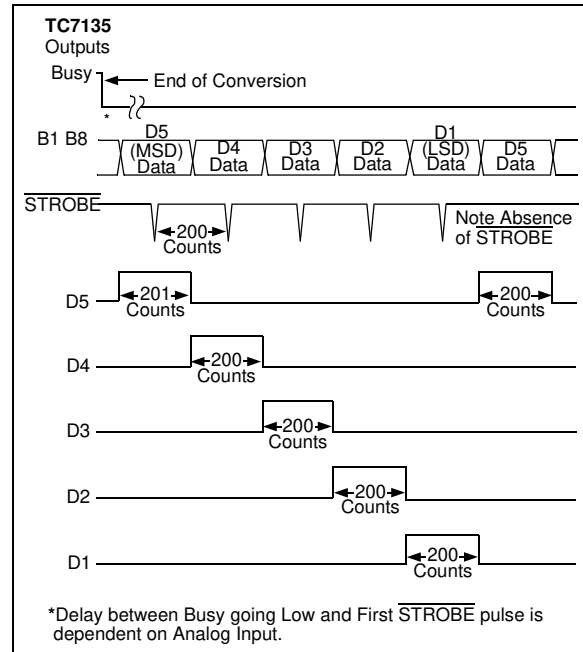

FIGURE 5-3: Strobe Signal Low Five Times Per Conversion.

5.3 BUSY Output

At the beginning of the signal integration phase, BUSY goes high and remains high until the first clock pulse after the integrator zero crossing. BUSY returns to the logic '0' state once the measurement cycle ends in an overrange condition. The internal display latches are loaded during the first clock pulse after BUSY and are latched at the clock pulse end. The BUSY signal does not go high at the beginning of the measurement cycle, which starts with the auto-zero cycle.

5.4 OVERRANGE Output

If the input signal causes the reference voltage integration time to exceed 20,000 clock pulses, the OVERRANGE output is set to a logic '1'. The OVERRANGE output register is set when BUSY goes low and is reset at the beginning of the next reference integration phase.

5.5 UNDERRANGE Output

If the output count is 9% of full scale or less (-1800 counts), the UNDERRANGE register bit is set at the end of BUSY. The bit is set low at the next signal integration phase.

5.6 POLARITY Output

A positive input is registered by a logic '1' polarity signal. The polarity bit is valid at the beginning of reference integrate and remains valid until determined during the next conversion.

The polarity bit is valid even for a zero reading. Signals less than the converter's LSB will have the signal polarity determined correctly. This is useful in null applications.

5.7 Digit Drive Outputs

Digit drive signals are positive-going signals. The scan sequence is D₅ to D₁. All positive pulses are 200 clock pulses wide, with the exception D₅, which is 201 clock pulses wide.

All five digits are scanned continuously, unless an overrange condition occurs. In an overrange condition, all digit drives are held low from the final STROBE pulse until the beginning of the next reference integrate phase. The scanning sequence is then repeated. This provides a blinking visual display indication.

5.8 BCD Data Outputs

The binary coded decimal (BCD) bits B₈, B₄, B₂ and B₁ are positive-true logic signals. The data bits become active at the same time as the digit drive signals. In an overrange condition, all data bits are at a logic '0' state.

6.0 TYPICAL APPLICATIONS

6.1 Component Value Selection

6.1.1 INTEGRATING RESISTOR

The integrating resistor R_{INT} is determined by the full-scale input voltage and the output current of the buffer used to charge the integrator capacitor (C_{INT}). Both the buffer amplifier and the integrator have a class A output stage, with 100 μ A of quiescent current. A 20 μ A drive current gives negligible linearity errors. Values of 5 μ A to 40 μ A give good results. The exact value of an integrating resistor for a 20 μ A current is easily calculated.

EQUATION 6-1:

$$R_{INT} = \frac{\text{Full Scale Voltage}}{20\mu\text{A}}$$

6.1.2 INTEGRATING CAPACITOR (C_{INT})

The product of integrating resistor and capacitor should be selected to give the maximum voltage swing that ensures the tolerance build-up will not saturate the integrator swing (approximately 0.3V from either supply). For \pm 5V supplies and ANALOG COMMON tied to supply ground, a \pm 3.5V to \pm 4V full scale integrator swing is adequate. A 0.10 μ F to 0.47 μ F is recommended. In general, the value of C_{INT} is given by:

EQUATION 6-2:

$$C_{INT} = \frac{[10,000 \times \text{clock period}] \times I_{INT}}{\text{integrator output voltage swing}}$$

$$= \frac{(10,000)(\text{clock period}) \times 20\mu\text{A}}{\text{integrator output voltage swing}}$$

A very important characteristic of the integrating capacitor C_{INT} is that it has low dielectric absorption to prevent rollover or ratiometric errors. A good test for dielectric absorption is to use the capacitor with the input tied to the reference. This ratiometric condition should read half scale 0.9999, with any deviation probably due to dielectric absorption. Polypropylene capacitors give undetectable errors at reasonable cost. Polystyrene and polycarbonate capacitors may also be used in less critical applications.

6.1.3 AUTO-ZERO AND REFERENCE CAPACITORS

The size of the auto-zero capacitor has some influence on the noise of the system, with a larger capacitor reducing the noise. The reference capacitor should be large enough such that stray capacitance to ground from its nodes is negligible.

The dielectric absorption of the reference and auto-zero capacitors are only important at power-on or when the circuit is recovering from an overload. Smaller or cheaper capacitors can be used if accurate readings are not required for the first few seconds of recovery.

6.1.4 REFERENCE VOLTAGE

The analog input required to generate a full-scale output is $V_{IN} = 2 V_{REF}$.

The stability of the reference voltage is a major factor in the overall absolute accuracy of the converter. For this reason, it is recommended that a high-quality reference be used where high-accuracy absolute measurements are being made.

6.2 Conversion Timing

6.2.1 LINE FREQUENCY REJECTION

A signal integration period at a multiple of the 60 Hz line frequency will maximize 60 Hz "line noise" rejection. A 100 kHz clock frequency will reject 50 Hz, 60 Hz and 400 Hz noise. This corresponds to five readings per second (see [Table 6-1](#) and [Table 6-2](#)).

TABLE 6-1: CONVERSION RATE VS. CLOCK FREQUENCY

Oscillator Frequency (kHz)	Conversion Rate (Conv./Sec.)
100	2.5
120	3
200	5
300	7.5
400	10
800	20
1200	30

TABLE 6-2: LINE FREQUENCY REJECTION VS. CLOCK FREQUENCY

Oscillator Frequency (kHz)	Line Frequency Rejection (Hz)
300	60
200	
150	
120	
100	
40	
33-1/3	
250	50
166-2/3	
125	
100	
100	50, 60, 400

The conversion rate is easily calculated:

EQUATION 6-3:

$$\text{Reading 1/sec} = \frac{\text{Clock Frequency (Hz)}}{4000}$$

6.3 High-Speed Operation

The maximum conversion rate of most dual-slope A/D converters is limited by the frequency response of the comparator. The comparator in this circuit follows the integrator ramp with a 3 μs delay, at a clock frequency of 160 kHz (6 μs period). Half of the first reference integrate clock period is lost in delay. This means that the meter reading will change from 0 to 1 with a 50 μV input, 1 to 2 with 150 μV, 2 to 3 at 250 μV, etc. This transition at midpoint is considered desirable by most users. However, if the clock frequency is increased appreciably above 200 kHz, the instrument will flash "1" on noise peaks, even when the input is shorted.

For many dedicated applications where the input signal is always of one polarity, the delay of the comparator need not be a limitation. Since the nonlinearity and noise do not increase substantially with frequency, clock rates of up to ~1 MHz may be used. For a fixed clock frequency, the extra count (or counts) caused by comparator delay will be a constant and can be subtracted out digitally.

The clock frequency may be extended above 160 kHz without this error, however, by using a low value resistor in series with the integrating capacitor. The effect of the resistor is to introduce a small pedestal voltage on to the integrator output at the beginning of the reference integrate phase. By careful selection of the ratio between this resistor and the integrating

resistor (a few tens of ohms in the recommended circuit), the comparator delay can be compensated and the maximum clock frequency extended by approximately a factor of 3. At higher frequencies, ringing and second-order breaks will cause significant nonlinearities in the first few counts of the instrument.

The minimum clock frequency is established by leakage on the auto-zero and reference capacitors. With most devices, measurement cycles as long as 10 seconds give no measurable leakage error.

The clock used should be free from significant phase or frequency jitter. Several suitable low-cost oscillators are shown in **Section 6.0 "Typical Applications"**. The multiplexed output means that if the display takes significant current from the logic supply, the clock should have good PSRR.

6.4 Zero Crossing Flip Flop

The flip flop interrogates the data once every clock pulse after the transients of the previous clock pulse and half clock pulse have died down. False zero crossings caused by clock pulses are not recognized. Of course, the flip flop delays the true zero crossing by up to one count in every instance. If a correction were not made, the display would always be one count too high. Therefore, the counter is disabled for one clock pulse at the beginning of the reference integrate (de-integrate) phase. This one-count delay compensates for the delay of the zero crossing flip flop and allows the correct number to be latched into the display. Similarly, a one-count delay at the beginning of auto-zero gives an overload display of 0000 instead of 0001. No delay occurs during signal integrate so that true ratiometric readings result.

6.5 Generating a Negative Supply

A negative voltage can be generated from the positive supply by using a TC7135 (see **Figure 6-1**).

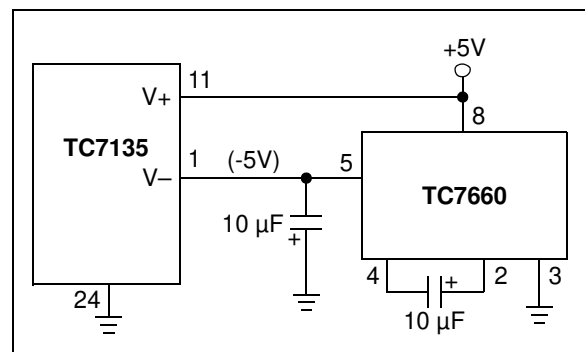

FIGURE 6-1: Negative Supply Voltage Generator.

TC7135

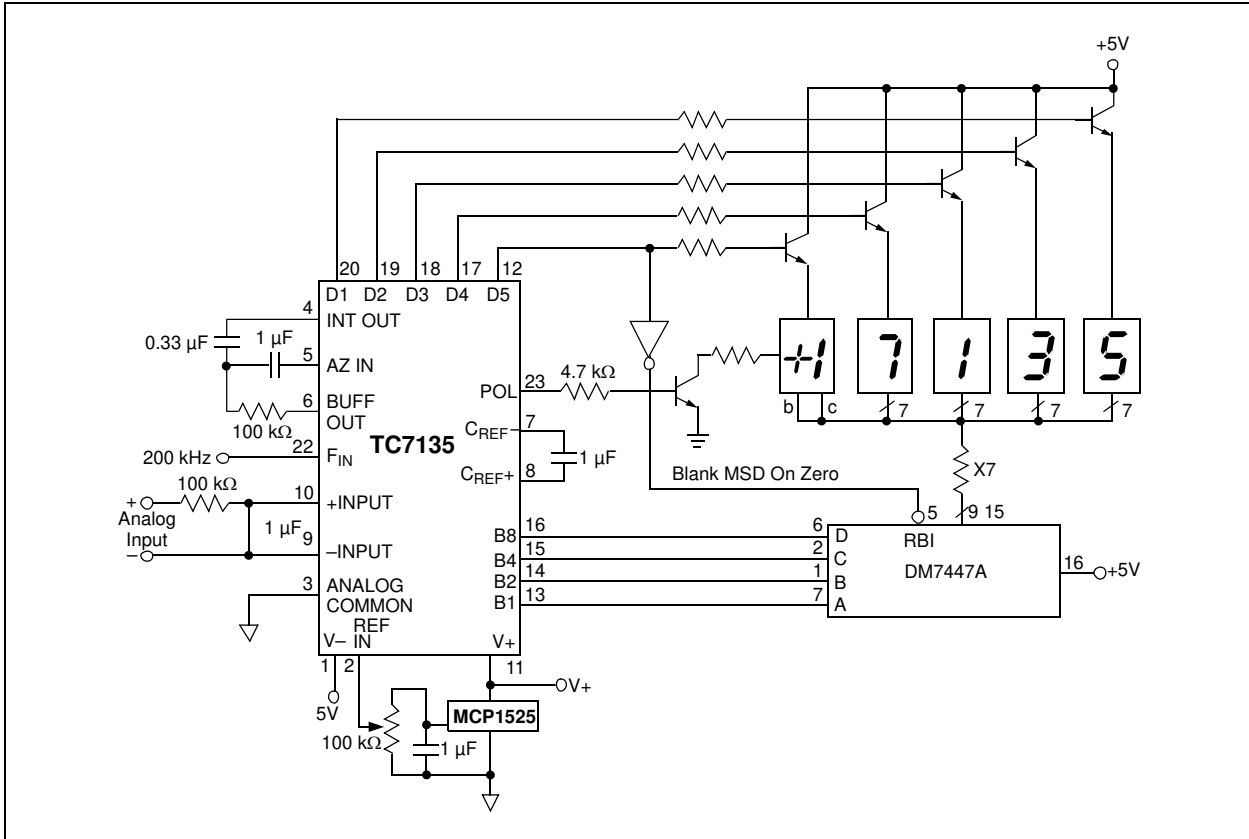

FIGURE 6-2: 4-1/2 Digit ADC With Multiplexed Common Anode Led Display.

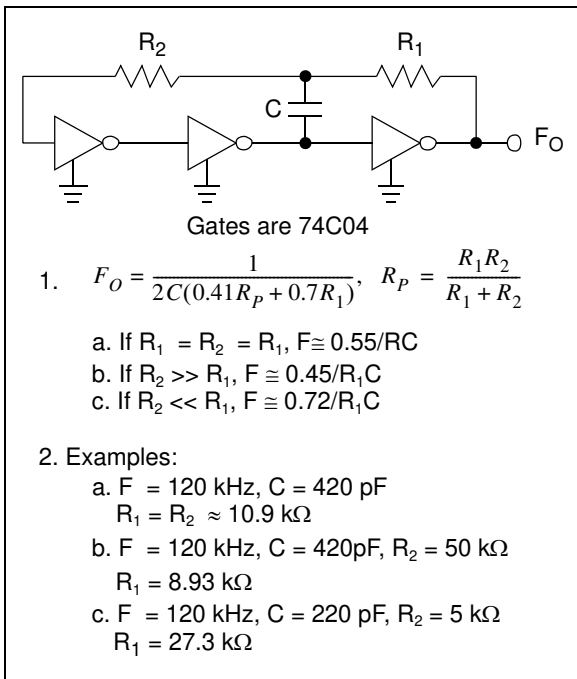

FIGURE 6-3: RC Oscillator Circuit.

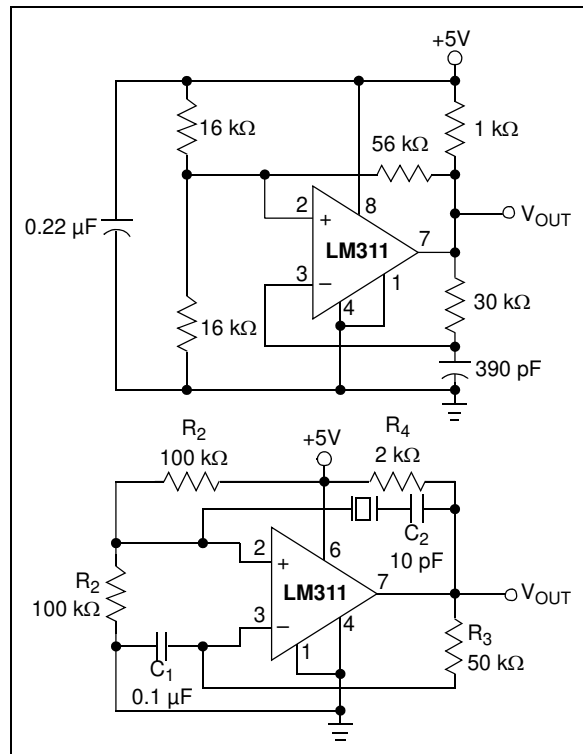

FIGURE 6-4: Comparator Clock Circuits.

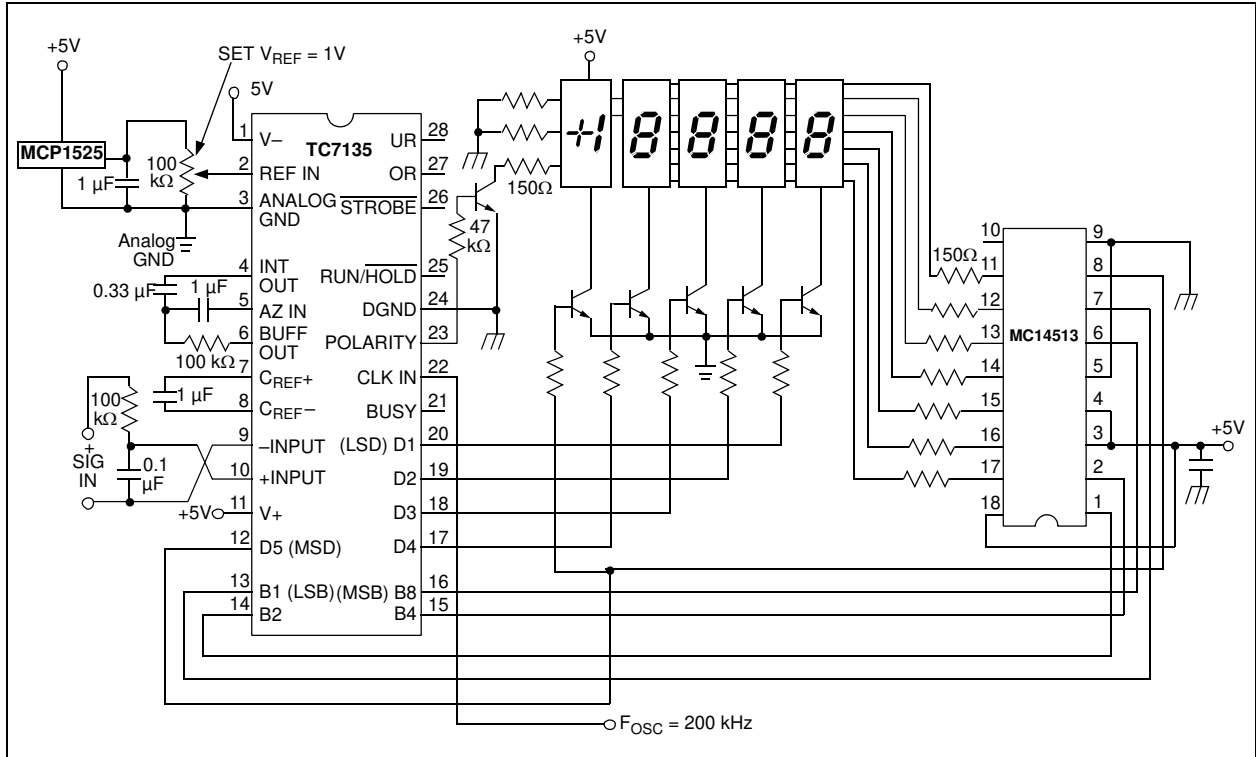

FIGURE 6-5: 4-1/2 Digit ADC With Multiplexed Common Cathode LED Display.

TC7135

7.0 PACKAGING INFORMATION

7.1 Package Marking Information

28-Pin PLCC

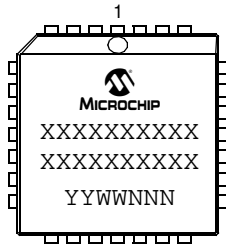

Example:

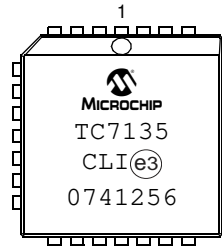

28-Pin PDIP (Wide)

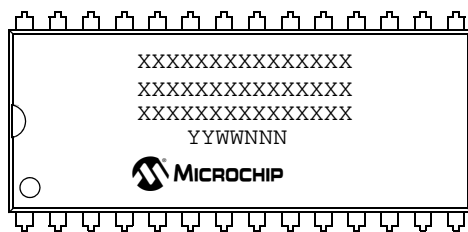

Example:

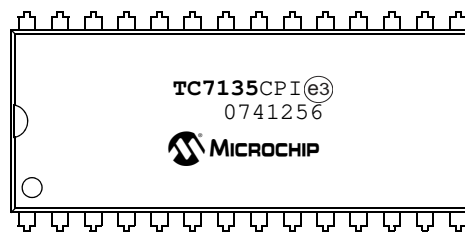

44-Pin MQFP

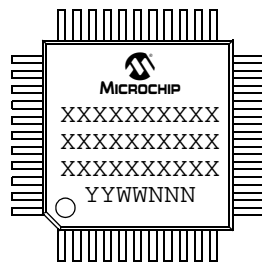

Example:

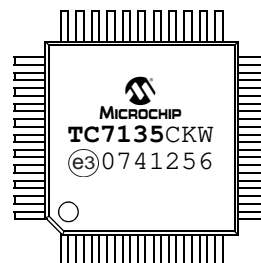

64-Pin MQFP

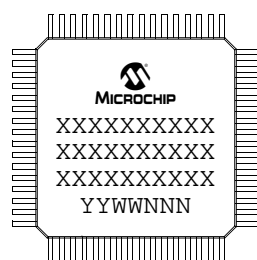

Example:

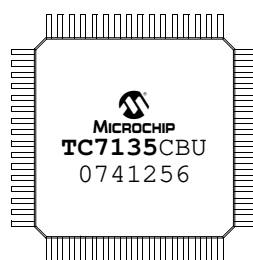

Legend:	XX...X	Customer-specific information
	Y	Year code (last digit of calendar year)
	YY	Year code (last 2 digits of calendar year)
	WW	Week code (week of January 1 is week '01')
	NNN	Alphanumeric traceability code
	(e3)	Pb-free JEDEC designator for Matte Tin (Sn)
	*	This package is Pb-free. The Pb-free JEDEC designator (e3) can be found on the outer packaging for this package.
Note:	In the event the full Microchip part number cannot be marked on one line, it will be carried over to the next line, thus limiting the number of available characters for customer-specific information.	

28-Lead Plastic Leaded Chip Carrier (LI) – Square [PLCC]

Note: For the most current package drawings, please see the Microchip Packaging Specification located at <http://www.microchip.com/packaging>

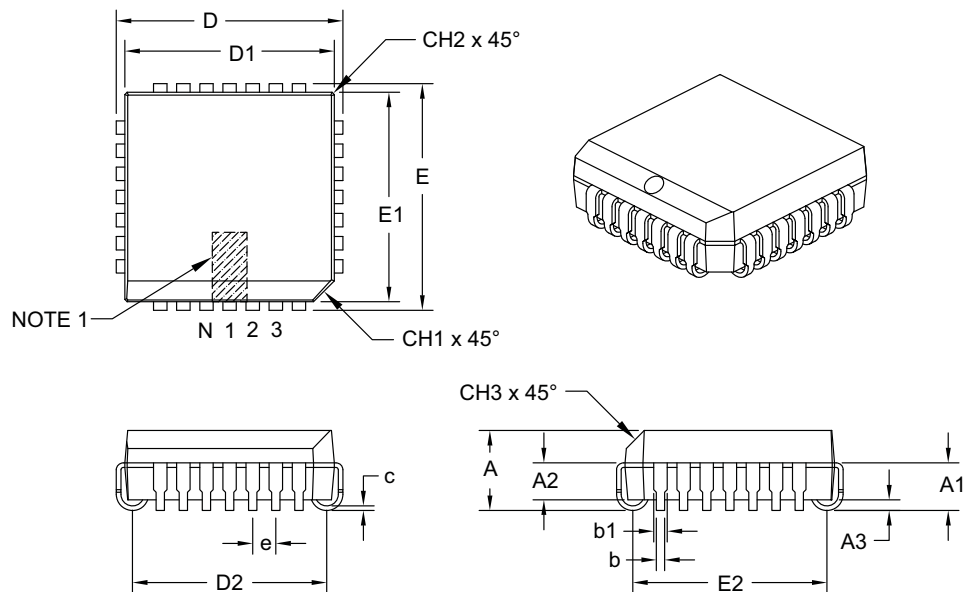

Dimension Limits	Units	INCHES		
		MIN	NOM	MAX
Number of Pins	N	28		
Pitch	e	.050		
Overall Height	A	.165	.172	.180
Contact Height	A1	.090	.105	.120
Molded Package to Contact	A2	.062	–	.083
Standoff §	A3	.020	–	–
Corner Chamfer	CH1	.042	–	.048
Chamfers	CH2	–	–	.020
Side Chamfer	CH3	.042	–	.056
Overall Width	E	.485	.490	.495
Overall Length	D	.485	.490	.495
Molded Package Width	E1	.450	.453	.456
Molded Package Length	D1	.450	.453	.456
Footprint Width	E2	.382	.410	.438
Footprint Length	D2	.382	.410	.438
Lead Thickness	c	.0075	–	.0125
Upper Lead Width	b1	.026	–	.032
Lower Lead Width	b	.013	–	.021

Notes:

1. Pin 1 visual index feature may vary, but must be located within the hatched area.
2. § Significant Characteristic.
3. Dimensions D1 and E1 do not include mold flash or protrusions. Mold flash or protrusions shall not exceed .010" per side.
4. Dimensioning and tolerancing per ASME Y14.5M.

Microchip Technology Drawing C04-026B

TC7135

28-Lead Plastic Dual In-Line (PI) – 600 mil Body [PDIP]

Note: For the most current package drawings, please see the Microchip Packaging Specification located at <http://www.microchip.com/packaging>

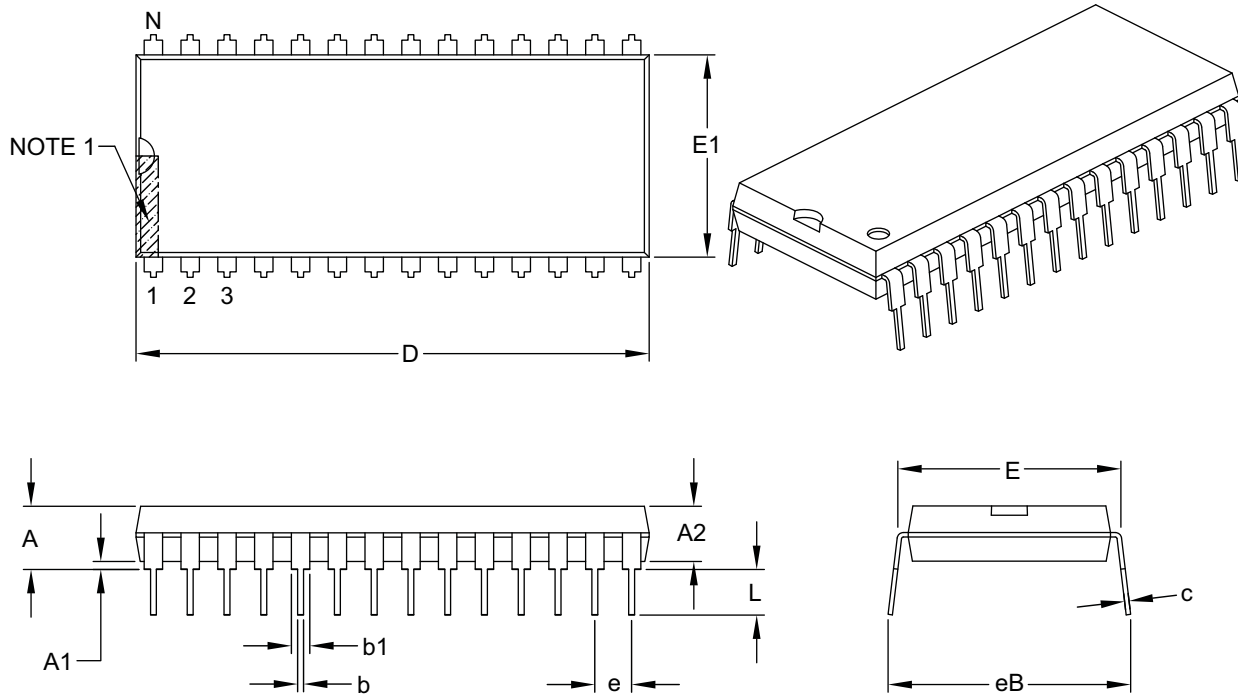

		Units	INCHES		
Dimension Limits			MIN	NOM	MAX
Number of Pins	N		28		
Pitch	e		.100 BSC		
Top to Seating Plane	A		–	–	.250
Molded Package Thickness	A2		.125	–	.195
Base to Seating Plane	A1		.015	–	–
Shoulder to Shoulder Width	E		.590	–	.625
Molded Package Width	E1		.485	–	.580
Overall Length	D		1.380	–	1.565
Tip to Seating Plane	L		.115	–	.200
Lead Thickness	c		.008	–	.015
Upper Lead Width	b1		.030	–	.070
Lower Lead Width	b		.014	–	.022
Overall Row Spacing §	eB		–	–	.700

Notes:

- Pin 1 visual index feature may vary, but must be located within the hatched area.
- § Significant Characteristic.
- Dimensions D and E1 do not include mold flash or protrusions. Mold flash or protrusions shall not exceed .010" per side.
- Dimensioning and tolerancing per ASME Y14.5M.

BSC: Basic Dimension. Theoretically exact value shown without tolerances.

Microchip Technology Drawing C04-079B

44-Lead Plastic Metric Quad Flatpack (KW) – 10x10x2 mm Body, 3.20 mm [MQFP]

Note: For the most current package drawings, please see the Microchip Packaging Specification located at <http://www.microchip.com/packaging>

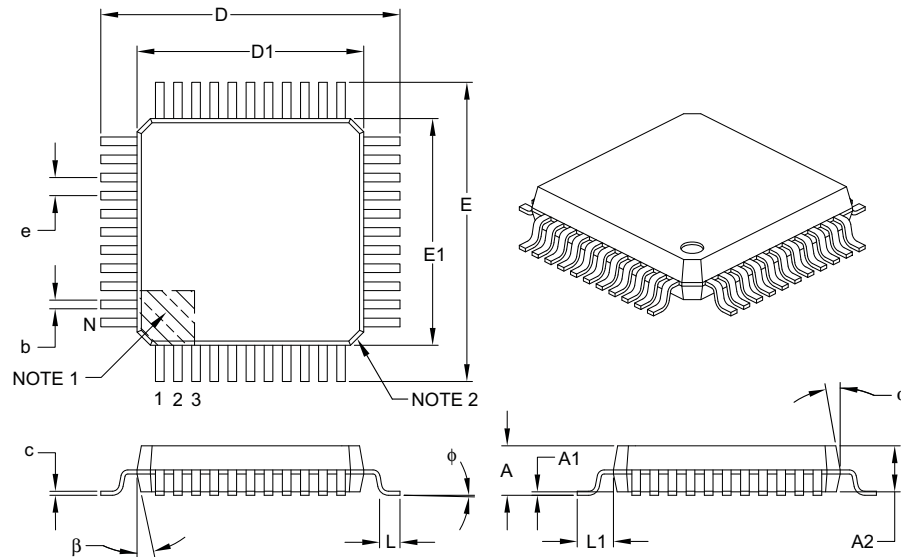

		Units	MILLIMETERS		
Dimension Limits			MIN	NOM	MAX
Number of Leads	N		44		
Lead Pitch	e		0.80 BSC		
Overall Height	A		–	–	2.45
Molded Package Thickness	A2		1.80	2.00	2.20
Standoff §	A1		0.00	–	0.25
Foot Length	L		0.73	0.88	1.03
Footprint	L1		1.60 REF		
Foot Angle	φ		0°	–	7°
Overall Width	E		13.20 BSC		
Overall Length	D		13.20 BSC		
Molded Package Width	E1		10.00 BSC		
Molded Package Length	D1		10.00 BSC		
Lead Thickness	c		0.11	–	0.23
Lead Width	b		0.29	–	0.45
Mold Draft Angle Top	α		5°	–	16°
Mold Draft Angle Bottom	β		5°	–	16°

Notes:

- Pin 1 visual index feature may vary, but must be located within the hatched area.
- Chamfers at corners are optional; size may vary.
- Dimensions D1 and E1 do not include mold flash or protrusions. Mold flash or protrusions shall not exceed 0.25 mm per side.
- Dimensioning and tolerancing per ASME Y14.5M.
 - BSC: Basic Dimension. Theoretically exact value shown without tolerances.
 - REF: Reference Dimension, usually without tolerance, for information purposes only.
- § Significant Characteristic.

Microchip Technology Drawing C04-071B

TC7135

64-Lead Plastic Metric Quad Flatpack (BU) – 14x14x2.7 mm Body, 3.20 mm [MQFP]

Note: For the most current package drawings, please see the Microchip Packaging Specification located at <http://www.microchip.com/packaging>

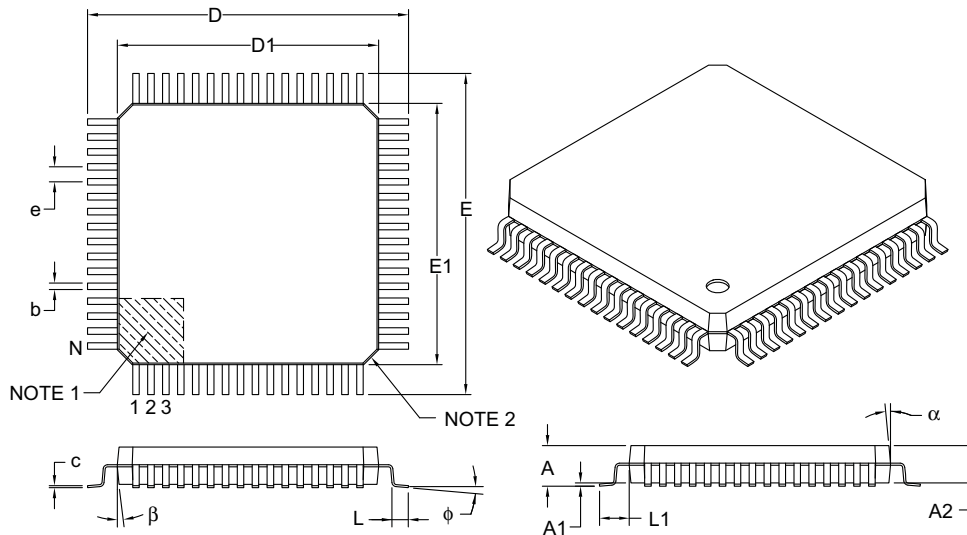

Dimension Limits	Units	MILLIMETERS		
		MIN	NOM	MAX
Number of Leads	N	64		
Lead Pitch	e	0.80 BSC		
Overall Height	A	–	–	3.15
Molded Package Thickness	A2	2.50	2.70	2.90
Standoff §	A1	0.00	–	0.25
Overall Width	E	17.20 BSC		
Molded Package Width	E1	14.00 BSC		
Overall Length	D	17.20 BSC		
Molded Package Length	D1	14.00 BSC		
Foot Length	L	0.73	0.88	1.03
Footprint	L1	1.60 REF		
Foot Angle	φ	0°	–	7°
Lead Thickness	c	0.11	–	0.23
Lead Width	b	0.29	–	0.45
Mold Draft Angle Top	α	5°	–	16°
Mold Draft Angle Bottom	β	5°	–	16°

Notes:

- Pin 1 visual index feature may vary, but must be located within the hatched area.
- Chamfers at corners are optional; size may vary.
- Dimensions D1 and E1 do not include mold flash or protrusions. Mold flash or protrusions shall not exceed 0.25 mm per side.
- Dimensioning and tolerancing per ASME Y14.5M.
BSC: Basic Dimension. Theoretically exact value shown without tolerances.
REF: Reference Dimension, usually without tolerance, for information purposes only.
- § Significant Characteristic.
- Formerly TelCom PQFP package.

Microchip Technology Drawing C04-022B

64-Lead Plastic Metric Quad Flatpack (BU) – 14x14x2.7 mm Body, 3.20 mm [MQFP]

Note: For the most current package drawings, please see the Microchip Packaging Specification located at <http://www.microchip.com/packaging>

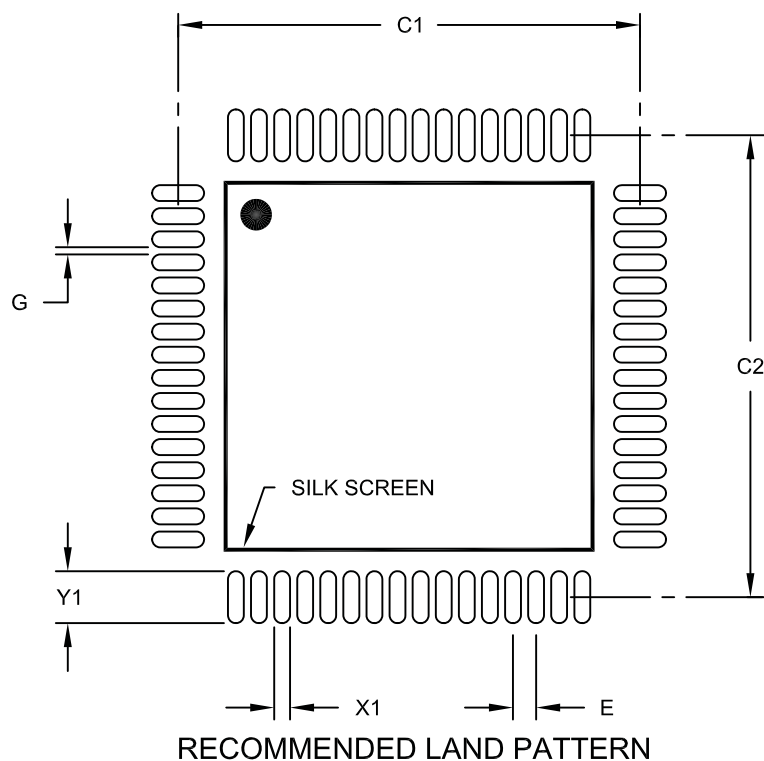

Dimension Limits	Units	MILLIMETERS		
		MIN	NOM	MAX
Contact Pitch	E	0.80 BSC		
Contact Pad Spacing	C1		16.10	
Contact Pad Spacing	C2		16.10	
Contact Pad Width (X64)	X1			0.55
Contact Pad Length (X64)	Y1			1.80
Distance Between Pads	G	0.25		

Notes:

1. Dimensioning and tolerancing per ASME Y14.5M

BSC: Basic Dimension. Theoretically exact value shown without tolerances.

Microchip Technology Drawing No. C04-2022A

TC7135

NOTES:

APPENDIX A: REVISION HISTORY

Revision D (November 2007)

The following is the list of modifications:

1. Updates package marking information for pb-free markings.
2. Updated package outline drawings and added landing pattern to applicable package outline drawing.

Revision C (January 2004)

The following is the list of modifications:

1. Undocumented Changes

Revision B (May 2002)

The following is the list of modifications:

1. Undocumented changes

Revision A (March 2001)

- Original Release of this Document.

TC7135

NOTES:

PRODUCT IDENTIFICATION SYSTEM

To order or obtain information, e.g., on pricing or delivery, refer to the factory or the listed sales office.

<u>PART NO.</u>	<u>X</u>	<u>/XX</u>
Device	Temperature Range	Package
Device TC7135: 4-1/2 Digit A/D, BCD Output	C = 0°C to +70°C	LI = Plastic Leaded Chip Carrier (PLCC), 28-lead LI713 = Plastic Leaded Chip Carrier (PLCC), 28-lead, Tape and Reel PI = Plastic DIP, (600 mil Body), 28-lead KW = Plastic Metric Quad Flatpack, (MQFP), 44-lead BU = Plastic Metric Quad Flatpack, (MQFP), 64-lead

Examples:

- a) TC7135CLI: 4-1/2 Digit A/D, BCD Output, PLCC package.
- b) TC7135CPI: 4-1/2 Digit A/D, BCD Output, PDIP package.
- c) TC7135CLI713: 4-1/2 Digit A/D, BCD Output, PLCC package, Tape and Reel.
- d) TC7135CBU: 4-1/2 Digit A/D, BCD Output, MQFP package.

TC7135

NOTES:

Note the following details of the code protection feature on Microchip devices:

- Microchip products meet the specification contained in their particular Microchip Data Sheet.
- Microchip believes that its family of products is one of the most secure families of its kind on the market today, when used in the intended manner and under normal conditions.
- There are dishonest and possibly illegal methods used to breach the code protection feature. All of these methods, to our knowledge, require using the Microchip products in a manner outside the operating specifications contained in Microchip's Data Sheets. Most likely, the person doing so is engaged in theft of intellectual property.
- Microchip is willing to work with the customer who is concerned about the integrity of their code.
- Neither Microchip nor any other semiconductor manufacturer can guarantee the security of their code. Code protection does not mean that we are guaranteeing the product as “unbreakable.”

Code protection is constantly evolving. We at Microchip are committed to continuously improving the code protection features of our products. Attempts to break Microchip's code protection feature may be a violation of the Digital Millennium Copyright Act. If such acts allow unauthorized access to your software or other copyrighted work, you may have a right to sue for relief under that Act.

Information contained in this publication regarding device applications and the like is provided only for your convenience and may be superseded by updates. It is your responsibility to ensure that your application meets with your specifications. MICROCHIP MAKES NO REPRESENTATIONS OR WARRANTIES OF ANY KIND WHETHER EXPRESS OR IMPLIED, WRITTEN OR ORAL, STATUTORY OR OTHERWISE, RELATED TO THE INFORMATION, INCLUDING BUT NOT LIMITED TO ITS CONDITION, QUALITY, PERFORMANCE, MERCHANTABILITY OR FITNESS FOR PURPOSE. Microchip disclaims all liability arising from this information and its use. Use of Microchip devices in life support and/or safety applications is entirely at the buyer's risk, and the buyer agrees to defend, indemnify and hold harmless Microchip from any and all damages, claims, suits, or expenses resulting from such use. No licenses are conveyed, implicitly or otherwise, under any Microchip intellectual property rights.

Trademarks

The Microchip name and logo, the Microchip logo, Accuron, dsPIC, KEELOQ, KEELOQ logo, microID, MPLAB, PIC, PICmicro, PICSTART, PRO MATE, rPIC and SmartShunt are registered trademarks of Microchip Technology Incorporated in the U.S.A. and other countries.

AmpLab, FilterLab, Linear Active Thermistor, Migratable Memory, MXDEV, MXLAB, SEEVAL, SmartSensor and The Embedded Control Solutions Company are registered trademarks of Microchip Technology Incorporated in the U.S.A.

Analog-for-the-Digital Age, Application Maestro, CodeGuard, dsPICDEM, dsPICDEM.net, dsPICworks, dsSPEAK, ECAN, ECONOMONITOR, FanSense, FlexROM, fuzzyLAB, In-Circuit Serial Programming, ICSP, ICEPIC, Mindi, MiWi, MPASM, MPLAB Certified logo, MPLIB, MPLINK, PICkit, PICDEM, PICDEM.net, PICLAB, PICtail, PowerCal, PowerInfo, PowerMate, PowerTool, REAL ICE, rLAB, Select Mode, Smart Serial, SmartTel, Total Endurance, UNI/O, WiperLock and ZENA are trademarks of Microchip Technology Incorporated in the U.S.A. and other countries.

SQTP is a service mark of Microchip Technology Incorporated in the U.S.A.

All other trademarks mentioned herein are property of their respective companies.

© 2007, Microchip Technology Incorporated, Printed in the U.S.A., All Rights Reserved.

 Printed on recycled paper.

QUALITY MANAGEMENT SYSTEM
CERTIFIED BY DNV
== ISO/TS 16949:2002 ==

Microchip received ISO/TS-16949:2002 certification for its worldwide headquarters, design and wafer fabrication facilities in Chandler and Tempe, Arizona; Gresham, Oregon and design centers in California and India. The Company's quality system processes and procedures are for its PIC® MCUs and dsPIC® DSCs, KEELOQ® code hopping devices, Serial EEPROMs, microperipherals, nonvolatile memory and analog products. In addition, Microchip's quality system for the design and manufacture of development systems is ISO 9001:2000 certified.



WORLDWIDE SALES AND SERVICE

AMERICAS

Corporate Office
2355 West Chandler Blvd.
Chandler, AZ 85224-6199
Tel: 480-792-7200
Fax: 480-792-7277
Technical Support:
<http://support.microchip.com>
Web Address:
www.microchip.com

Atlanta
Duluth, GA
Tel: 678-957-9614
Fax: 678-957-1455

Boston
Westborough, MA
Tel: 774-760-0087
Fax: 774-760-0088

Chicago
Itasca, IL
Tel: 630-285-0071
Fax: 630-285-0075

Dallas
Addison, TX
Tel: 972-818-7423
Fax: 972-818-2924

Detroit
Farmington Hills, MI
Tel: 248-538-2250
Fax: 248-538-2260

Kokomo
Kokomo, IN
Tel: 765-864-8360
Fax: 765-864-8387

Los Angeles
Mission Viejo, CA
Tel: 949-462-9523
Fax: 949-462-9608

Santa Clara
Santa Clara, CA
Tel: 408-961-6444
Fax: 408-961-6445

Toronto
Mississauga, Ontario,
Canada
Tel: 905-673-0699
Fax: 905-673-6509

ASIA/PACIFIC

Asia Pacific Office
Suites 3707-14, 37th Floor
Tower 6, The Gateway
Harbour City, Kowloon
Hong Kong
Tel: 852-2401-1200
Fax: 852-2401-3431

Australia - Sydney
Tel: 61-2-9868-6733
Fax: 61-2-9868-6755

China - Beijing
Tel: 86-10-8528-2100
Fax: 86-10-8528-2104

China - Chengdu
Tel: 86-28-8665-5511
Fax: 86-28-8665-7889

China - Fuzhou
Tel: 86-591-8750-3506
Fax: 86-591-8750-3521

China - Hong Kong SAR
Tel: 852-2401-1200
Fax: 852-2401-3431

China - Nanjing
Tel: 86-25-8473-2460
Fax: 86-25-8473-2470

China - Qingdao
Tel: 86-532-8502-7355
Fax: 86-532-8502-7205

China - Shanghai
Tel: 86-21-5407-5533
Fax: 86-21-5407-5066

China - Shenyang
Tel: 86-24-2334-2829
Fax: 86-24-2334-2393

China - Shenzhen
Tel: 86-755-8203-2660
Fax: 86-755-8203-1760

China - Shunde
Tel: 86-757-2839-5507
Fax: 86-757-2839-5571

China - Wuhan
Tel: 86-27-5980-5300
Fax: 86-27-5980-5118

China - Xian
Tel: 86-29-8833-7252
Fax: 86-29-8833-7256

ASIA/PACIFIC

India - Bangalore
Tel: 91-80-4182-8400
Fax: 91-80-4182-8422

India - New Delhi
Tel: 91-11-4160-8631
Fax: 91-11-4160-8632

India - Pune
Tel: 91-20-2566-1512
Fax: 91-20-2566-1513

Japan - Yokohama
Tel: 81-45-471- 6166
Fax: 81-45-471-6122

Korea - Daegu
Tel: 82-53-744-4301
Fax: 82-53-744-4302

Korea - Seoul
Tel: 82-2-554-7200
Fax: 82-2-558-5932 or
82-2-558-5934

Malaysia - Kuala Lumpur
Tel: 60-3-6201-9857
Fax: 60-3-6201-9859

Malaysia - Penang
Tel: 60-4-227-8870
Fax: 60-4-227-4068

Philippines - Manila
Tel: 63-2-634-9065
Fax: 63-2-634-9069

Singapore
Tel: 65-6334-8870
Fax: 65-6334-8850

Taiwan - Hsin Chu
Tel: 886-3-572-9526
Fax: 886-3-572-6459

Taiwan - Kaohsiung
Tel: 886-7-536-4818
Fax: 886-7-536-4803

Taiwan - Taipei
Tel: 886-2-2500-6610
Fax: 886-2-2508-0102

Thailand - Bangkok
Tel: 66-2-694-1351
Fax: 66-2-694-1350

EUROPE

Austria - Wels
Tel: 43-7242-2244-39
Fax: 43-7242-2244-393

Denmark - Copenhagen
Tel: 45-4450-2828
Fax: 45-4485-2829

France - Paris
Tel: 33-1-69-53-63-20
Fax: 33-1-69-30-90-79

Germany - Munich
Tel: 49-89-627-144-0
Fax: 49-89-627-144-44

Italy - Milan
Tel: 39-0331-742611
Fax: 39-0331-466781

Netherlands - Drunen
Tel: 31-416-690399
Fax: 31-416-690340

Spain - Madrid
Tel: 34-91-708-08-90
Fax: 34-91-708-08-91

UK - Wokingham
Tel: 44-118-921-5869
Fax: 44-118-921-5820

10/05/07