

(5:1)

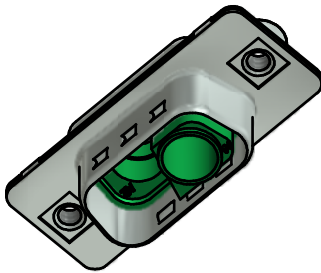
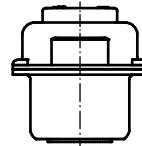
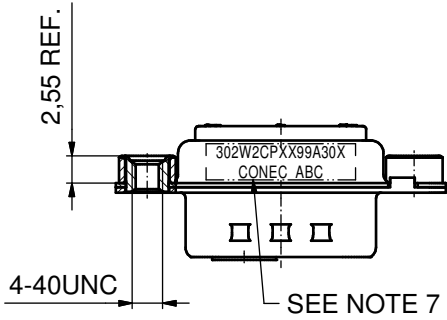
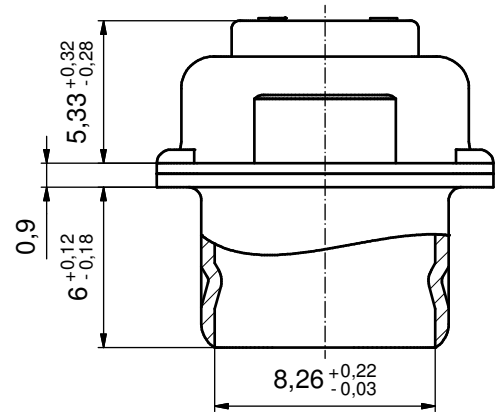
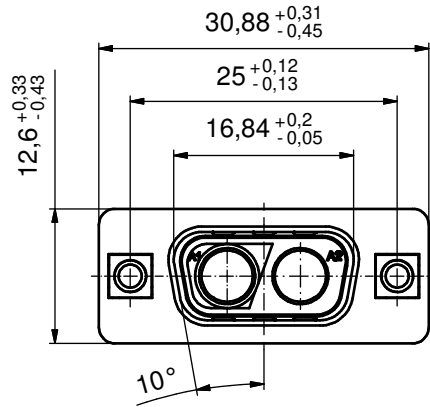

NOTES:

1. METAL SHELLS: STEEL; min. 315µm TIN over 40-80µm NICKEL
2. INSULATOR: PBT GF UL 94 V-0; GREEN
3. NO CONTACTS ON POS. A1 + A2
4. THREADED INSERTS: COPPER ALLOY; min. 200µm TIN over 80µm NICKEL
5. COLLARS: COPPER ALLOY; min. 200µm TIN over 80µm NICKEL
6. MAXIMUM TORQUE VALUE FOR THREAD: 6 in.LB
7. CONNECTOR IS PART MARKED: 302W2CPXX99A30X CONEC ABC

Directive 2002/95/EC RoHS compliant

THIS DRAWING MAY NOT BE COPIED OR REPRODUCED IN ANY WAY, AND MAY NOT BE PASSED ON TO A THIRD PARTY WITHOUT WRITTEN PERMISSION. OWNERSHIP AND COPYRIGHT OF CONEC GmbH DO NOT ALTER CAD DRAWING BY HAND	tolerance		dim. in mm		scale: 2:1 (5:1)	
					material: SEE NOTES	
			date	name	title:	
			drawn	02.03.11	D-SUB COMBINATON MALE	
			appd.	02.03.11	2W2CP	
			norm		with threaded insert	
			d-old		dwg no: Inventor 10	
a	Origin			DIN-A3		
rev.	description	date	name	sh: 1		
CONEC [®]				part no: 302W2CPXX99A30X		