



# LED Display Product Data Sheet LTM-8530P

Spec No.: DS-30-98-339

Effective Date: 06/23/2000

Revision: -

**LITE-ON DCC**

**RELEASE**

BNS-OD-FC001/A4

**FEATURES**

- \* 0.56 INCH (14.22 mm) DIGIT HEIGHT.
- \* WIDE SUPPLY VOLTAGE OPERATION.
- \* SERIAL DATA INPUT.
- \* CONSTANT CURRENT DRIVERS.
- \* CONTINUOUS BRIGHTNESS CONTROL.
- \* SOLID STATE RELIABILITY-LONG OPERATION LIFE.
- \* WIDE VIEWING ANGLE.
- \* TTL COMPATIBLE.

**DESCRIPTION**

The LTM-8530P is a 0.56 inch (14.22 mm) numeric display modules, and a built-in M5450 MOS integrated circuits. The integrated circuit contains serial data input, 35 bits shift register. 34 LED driver output and a brightness control. This device utilizes bright red LED chips, which are made from GaP on a transparent GaP substrate, and has a black face and red segments. The MOS integrated circuits are produced with N-channel silicon gate technology.

**DEVICE**

<b>PART NO.</b>	<b>DESCRIPTION</b>
BRIGHT RED	2 Digit
LTM-8530P	Rt. Hand Decimal

**PACKAGE DIMENSIONS**

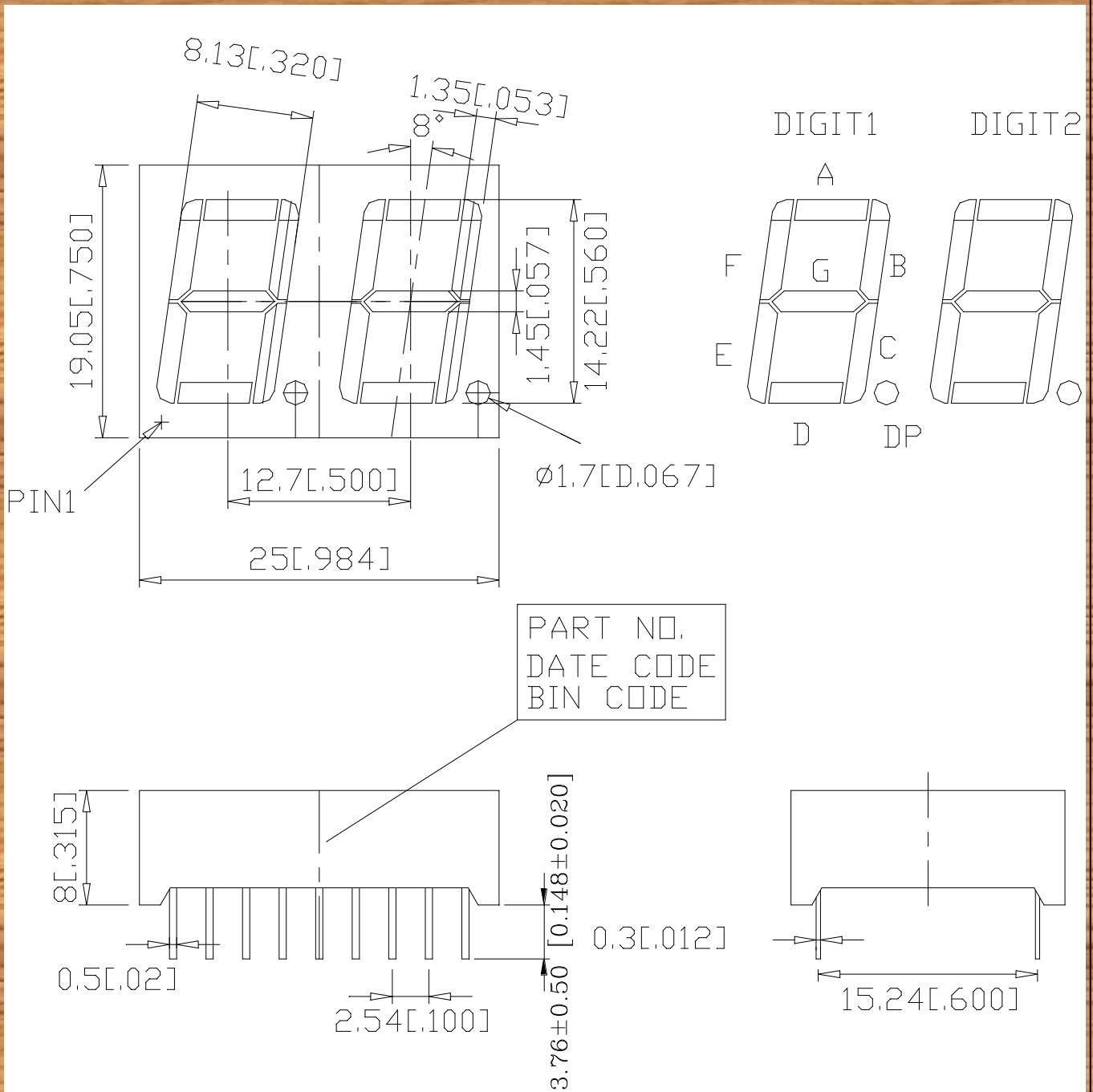

NOTES: All dimensions are in millimeters. Tolerances are ± 0.25 mm (0.01") unless otherwise noted.

**PIN CONNECTION**

<b>No.</b>	<b>CONNECTION</b>
1	VSS
2	VLED
3	NO PIN
4	NO PIN
5	NO PIN
6	BIT 17 OUTPUT
7	BIT 18 OUTPUT
8	BIT 19 OUTPUT
9	BIT 20 OUTPUT
10	BIT 21 OUTPUT
11	BIT 22 OUTPUT
12	BIT 23 OUTPUT
13	BIT 24 OUTPUT
14	DATA ENABLE
15	DATA INPUT
16	CLOCK INPUT
17	VDD
18	BRT. CONTROL



**ABSOLUTE MAXIMUM RATING AT T<sub>A</sub>=25°C**

PARAMETER	Symbol	Min.	Max.	UNIT
Supply Voltage *1	VDD	-0.3	12	V
Input Voltage	VI	-0.3	12	V
Off State Output Voltage	VO(off)		12	V
LED Supply Voltage	VLED	2.8	3.5	V
Power Dissipation of IC *2	PD(IC)		335	mW
Supply Current	IDD		8.5	mA
Operating Temperature Range	Top	-20	+60	°C
Storage Temperature Range	Tstg	-20	+60	°C
Solder Temperature: max 260°C for max 3sec at 1.6mm below seating plane.				

Note: 1. All voltage are with respect to Vss(GND)

2. Power dissipation of IC is given by  $PD=(VLED-VF) \cdot (IF) \cdot (\text{No. of Segments})+(8.5\text{mA}) \cdot (VDD)$

\*VF is LED forward voltage.

**RECOMMENDED OPERATING CONDITION AT T<sub>A</sub>=25°C**

Parameter	Symbol	Min.	Typ.	Max.	Unit	Test Condition
Supply Voltage	VDD	4.75		11	V	
Input Voltage						
Logical "0" Level		-0.3		0.8	V	±10μA Input Bias
Logical "1" Level	VI	2.2		VDD	V	4.75V < VDD < 5.25V
Logical "1" Level		VDD -2		VDD	V	VDD > 5.25V
Brightness Input Current	IB	0		0.75	mA	
Brightness Input Voltage	VB	3		4.3	V	Input Current=750 μA
Off State Voltage	VO(off)			11	V	
Output Sink Current						
Segment Off				10	μA	IB=0 μA
Segment On			3		mA	IB=100 μA
			6		mA	IB=200 μA
Input Clock Frequency	FCLOCK	0		0.5	MHZ	
Output Matching	IO			±20	%	

**ELECTRICAL/OPTICAL CHARACTERISTICS AT Ta=25°C**

PARAMETER	SYMBOL	MIN.	TYP.	MAX.	UNIT	TEST CONDITION
Average Luminous Intensity	I <sub>v</sub>	320	950		μcd	I <sub>B</sub> =0.4mA
Peak Emission Wavelength	λ <sub>p</sub>		697		nm	I <sub>B</sub> =0.4mA
Spectral Line Half-Width	Δλ		90		nm	I <sub>B</sub> =0.4mA
Dominant Wavelength	λ <sub>d</sub>		657		nm	I <sub>F</sub> =20mA
Luminous Intensity Matching Ratio	I <sub>v-m</sub>			2:1		I <sub>B</sub> =0.4mA

**FUNCTIONAL DESCRIPTION**

Serial data transfer from the data source to the display driver is accomplished with 2 signals serial data and clock. Using a format of a leading “1” followed by the 35 data bits allow data transfer without an additional load signal. The 35 data bits are latched after the 36<sup>th</sup> bit is completed, thus providing non multiplexed, direct drive to the display. Outputs change only if the serial data bits differ from the previous time.

Brightness of display is determined by control the output current of LED display. A 1nF capacitor should be connected to brightness control, Pin 7 to prevent possible oscillations. The output current is typically 25 times greater than the current into Pin 7 which is set by an external variable resistor. There is an internal limiting resistor of 400 Ω nominal value.

Figure 1 shows the input data format. A start bit of logical “1” proceed the 35 bits of data. At the 36<sup>th</sup> clock, a LOAD signal is generated synchronously with the high state of the clock, which loads the 35 bits of the shift registers into the latches. At the low state of the clock a RESET signal is generated which clears all the shift registers for the next set of data. The shift registers are static master-slave configuration. There is no clear for master portion of the first register, thus allowing continuous operation.

There must be a complete set of 36 clocks or the shift registers won't clear. When power is first applied to the chip, an internal power ON, a reset signal is generated which reset all registers and all latches. The START bit and first clock return the chip on its normal operation. Bit 1 is the first following the start bit and it will appear on the segment A of the digit 1. A logical “1” at the input will turn on the appropriate LED. Figure 2 shows the timing relationship between data, clock, and DATA ENABLE. A max. clock frequency of 0.5 MHz is assumed.



**FIGURE 1. INTERNAL BLOCK DIAGRAM**

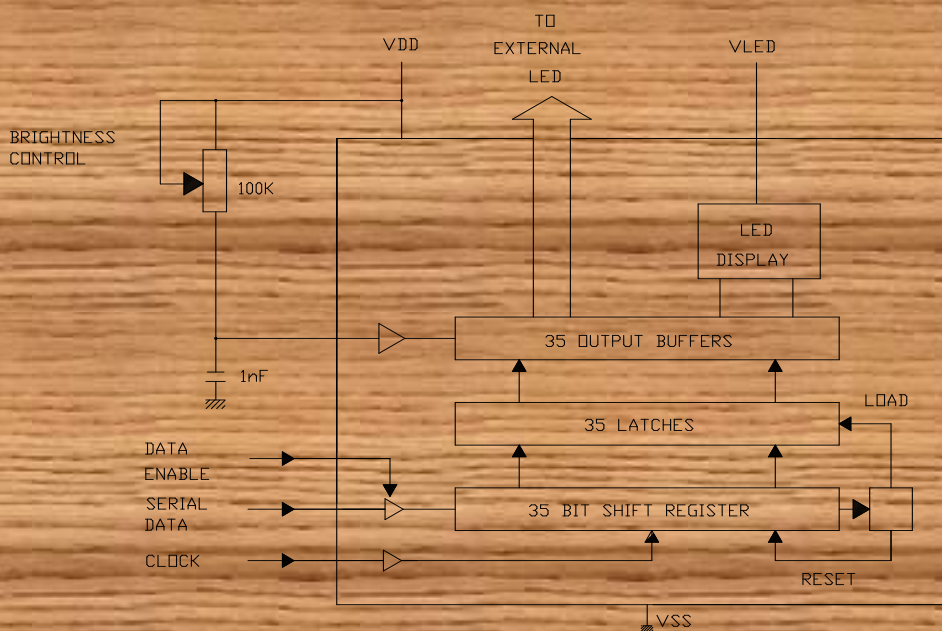

**FIGURE 2. INPUT DATA FORMAT**

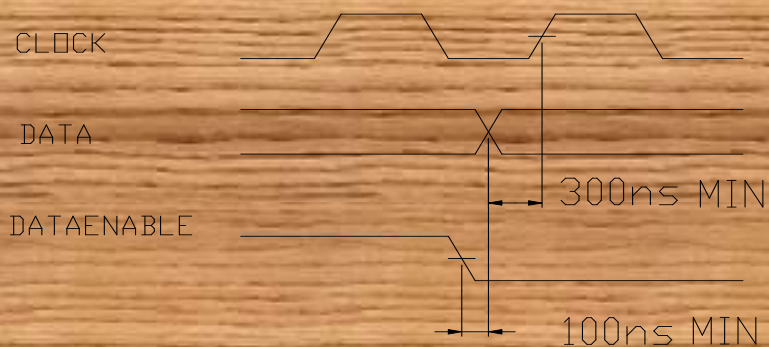

**FIGURE 3. TIMING RELATIONSHIP**

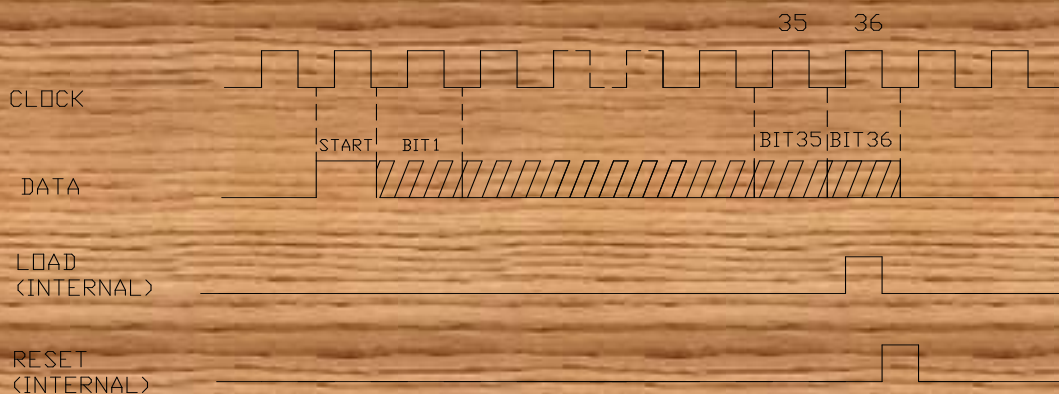

**TABLE 1 SERIAL DATA INPUT SEQUENCE**

BIT	LTM-8530	
	DIGIT	SEGMENT
1	1	A
2	1	B
3	1	C
4	1	D
5	1	E
6	1	F
7	1	G
8	1	D.P.
9	2	A
10	2	B
11	2	C
12	2	D
13	2	E
14	2	F
15	2	G
16	2	D.P.
17		PIN 6
18		PIN 7
19		PIN 8
20		PIN 9
21		PIN 10
22		PIN 11
23		PIN 12
24		PIN 13
25		NO CONNECTION
26		NO CONNECTION
27		NO CONNECTION
28		NO CONNECTION
29		NO CONNECTION
30		NO CONNECTION
31		NO CONNECTION
32		NO CONNECTION
33		NO CONNECTION
34		NO CONNECTION

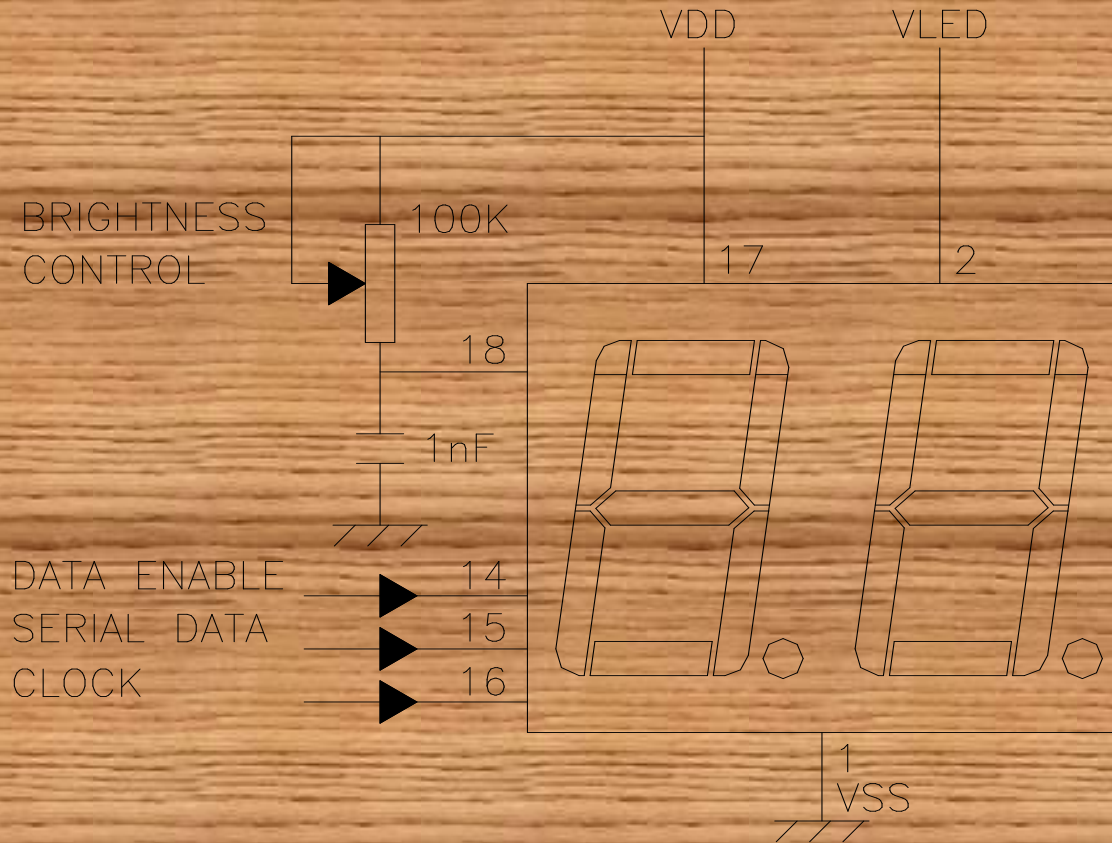

**TYPICAL APPLICATION**

NOTES: 1. Clean only in water, isopropanol, ethanol, freon TF(or equivalent).

2. Luminous intensity is measured with a light sensor and filter combination that approximates the CIE (Commision Internationale De L'Eclairage)eye-response curve.