



Category PC1:

No integral protection against electric shock. If required, Designers/ Manufacturers must provide additional protection against electric shock on equipment.

Category PC2:

With integral protection against electric shock. Fuse-holders shall have live parts inaccessible to IEC 529 Standard Test Finger, when fully assembled, without fuse carrier or fuse in place and when fuse carrier, with fuse is being inserted or withdrawn.

Category PC3:

With integral protection against electric shock. Fuse-holders shall have live parts inaccessible to IEC 529 1mm dia. rigid test wire when fully assembled, without fuse carrier or fuse in place and when fuse carrier, with fuse is being inserted or withdrawn.

For full definitions see IEC 127-6 : 1994 Clause 9



Certificate No. FM12622

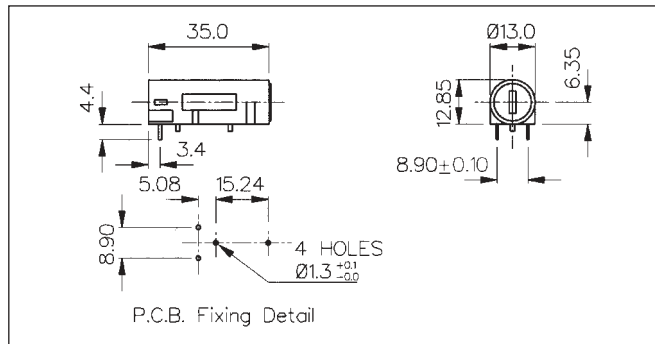
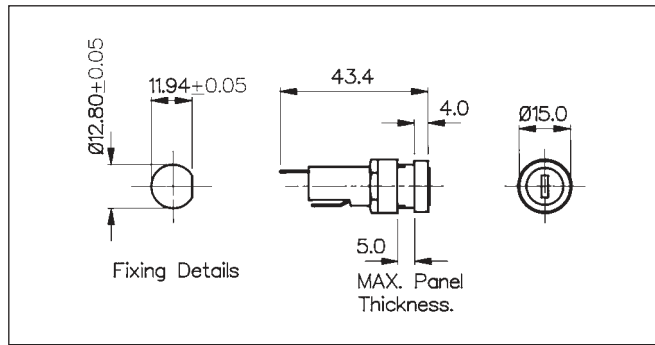
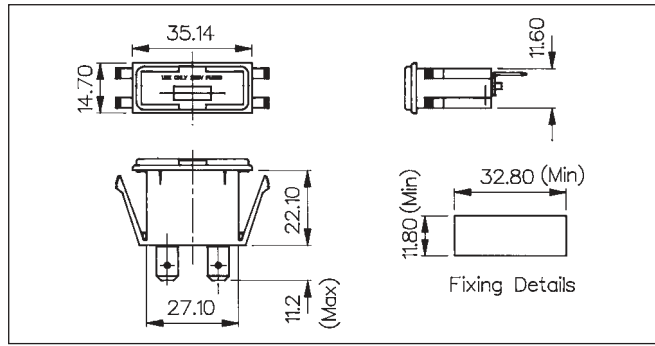

Data	List No.	FX0430/Termination	FX0460	FX0461
Fuse Size:		5 x 20	5 x 20	5 x 20
Fuse Carrier:		Captive Drawer	Screw cap, screwdriver release.	Screw cap, screwdriver release.
Terminations:		/ 28 (2.8mm solder), / 48 (4.8mm tab), / 63 (6.3mm tab)	2.8 series tabs/ solder tags.	p.c. spills.
Max. Rating:		10A 250V	10A. 250V.	10A. 250V.
Max. Power Dissipation:		2.5W (@ 23°C).	2.5W. (@ 23°C).	2.5W. (@ 23°C).
Insulation Resistance:		>10MΩ @ 500V d.c.	>10MΩ @ 500V d.c.	>10MΩ @ 500V d.c.
A.C. Breakdown:		>2kV	>2kV.	>2kV.
Contact Resistance:		<10mΩ.	<10mΩ.	<10mΩ.
Mouldings:		Body/ Drawer: Nylon.	Body: Polyester. Cap: Nylon. Nut: Glass Filled Nylon.	Body: Polyester. Cap: Nylon.
Contacts:		Contact tags: Brass, Tin Plated Fuse Clips: Phosphor Bronze, Nickel Plated	Brass, Silver Plated.	Brass, Silver Plated.
Approvals:		*Pending	*Pending	*Pending
Accessories:			PNo. 11327. (see page 152)	
Protection classification:		PC3	PC3	PC3



* See Page 140

FUSE HOLDERS

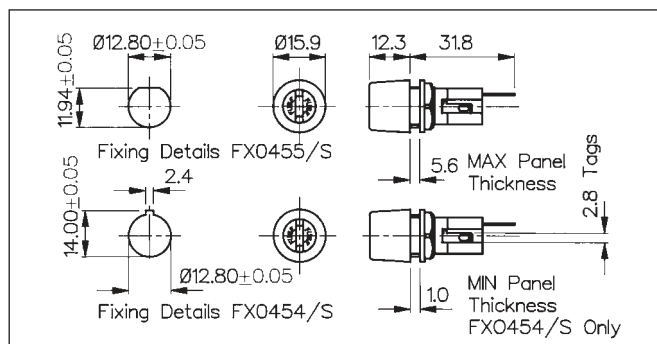
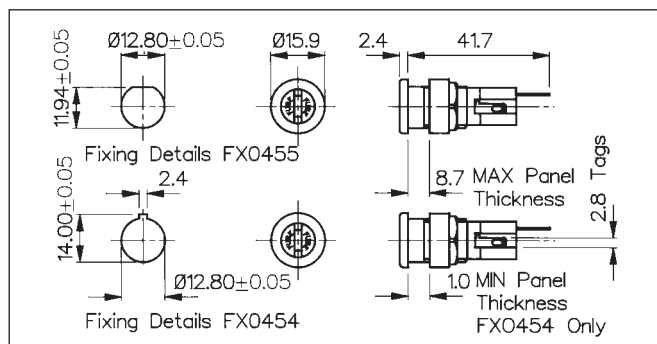
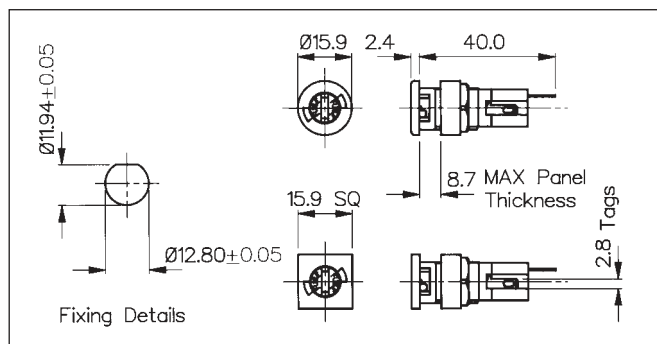

Data	List No.	FX0357, FX0359	FX0454, FX0455	FX0454/S, FX0455/S
Fuse Size:		5 x 20	5 x 20	5 x 20
Fuse Carrier:		Bayonet cap, screwdriver release.	Screw cap, screwdriver release.	Screw cap, screwdriver release.
Terminations:		2.8 series tabs/ solder tags.	2.8 series tabs/ solder tags.	2.8 series tabs/ solder tags.
Max. Rating:		10A. 250V.	10A. 250V.	10A. 250V.
Max. Power Dissipation:		4W. (@ 23°C).	4W. (@ 23°C).	4W. (@ 23°C).
Insulation Resistance:		>10 ² MΩ @ 500V d.c.	>10 ² MΩ @ 500V d.c.	>10 ² MΩ @ 500V d.c.
A.C. Breakdown:		7kV @ 50Hz.	7kV @ 50Hz.	7kV @ 50Hz.
Contact Resistance:		<10mΩ.	<10mΩ.	<10mΩ.
Mouldings:		Body: Polyester. Cap: Nylon. Nut: Glass Filled Nylon.	Body: Polyester. Cap: Nylon. Nut: Glass Filled Nylon.	Body: Polyester. Cap: Nylon. Nut: Glass Filled Nylon.
Contacts:		Brass, Silver Plated.	Brass, Silver Plated.	Brass, Silver Plated.
Approvals:				
Accessories:		P.No.11327 (see page 152)	P.Nos. 11327, 12297 & 12298 (see page 152)	P.Nos. 11327, 12297 & 12298 (see page 152)
Notes:			Designed to conform with British Telecom 172D.	Designed to conform with British Telecom 172D.

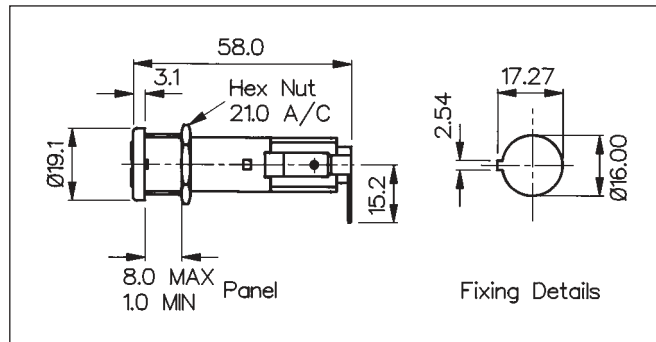
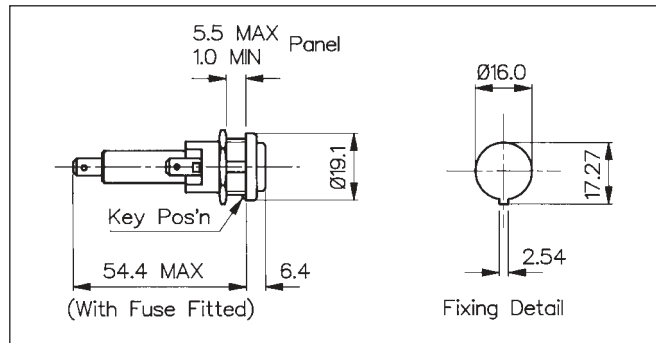
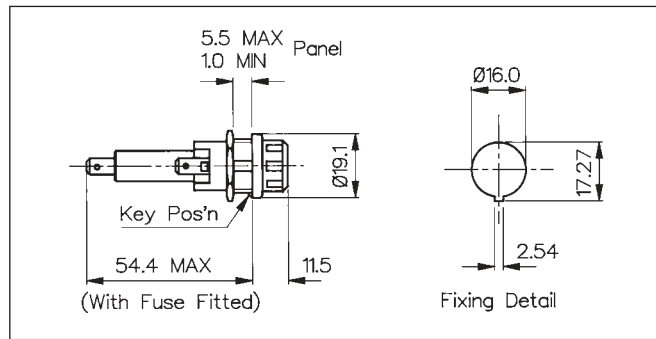

FUSE HOLDERS



Data \ List No.	FX0415	FX0416	FX0415/S	FX0416/S	FX0417
Fuse Size:	6.3 x 32	6.3 x 25	6.3 x 32	6.3 x 25	6.3 x 32
Fuse Carrier:	Screw cap, hand release.		Screw cap, screwdriver release.		Screw cap, screwdriver release.
Terminations:	4.8 series tabs.		4.8 series tabs.		6.3 series tabs.
Max. Rating:	13A, 250V.		13A, 250V.		16A, 250V. (20A, 250V)
Max. Power Dissipation:	4W. (@ 23°C).		4W. (@ 23°C).		4W. (@ 23°C).
Insulation Resistance:	>10 ⁵ MΩ @ 500V d.c.		>10 ⁵ MΩ @ 500V d.c.		>10MΩ @ 500V d.c.
A.C. Breakdown:	4kV @ 50Hz.		4kV @ 50Hz.		>2KV
Contact Resistance:	<5mΩ.		<5mΩ.		<10mΩ.
Mouldings:	Body: Glass Filled Nylon. Cap: Nylon. Sleeve: Phenolic.		Body: Glass Filled Nylon. Cap: Nylon. Sleeve: Phenolic.		Body: Glass Filled Polyester. Cap: Nylon. Sleeve: Phenolic.
Contacts:	Brass, Silver Plated.		Brass, Silver Plated.		Brass, Silver Plated.
Approvals:					
Accessories:	P.No.12932 (see page 152)		P.No.12932 (see page 152)		



* See Page 140

FUSE HOLDERS

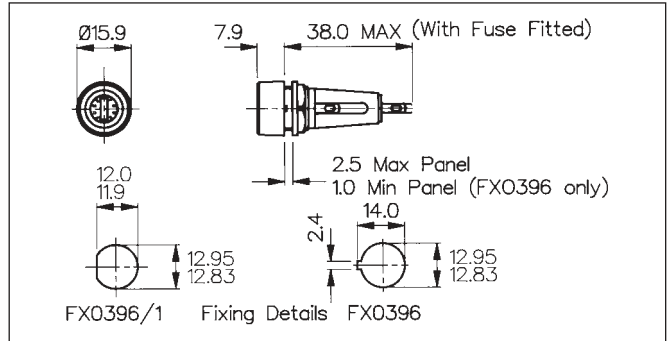
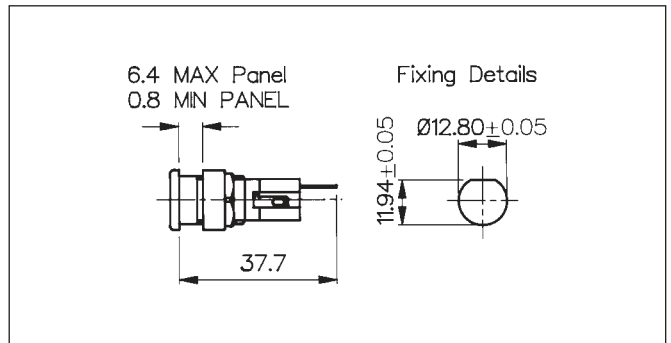
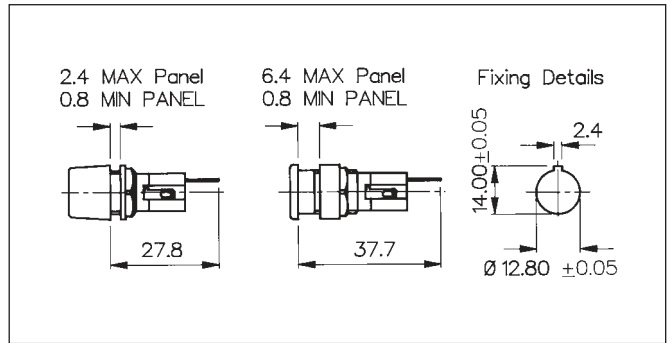

Data	List No.	FX0354, FX0354/S	FX0355	FX0396, FX0396/1
Fuse Size:		5 x 20	5 x 20	5 x 20
Fuse Carrier:		Screw cap, screwdriver release.	Screw cap, screwdriver release.	Screw cap, screwdriver release.
Terminations:		2.8 series tabs/ solder tags.	2.8 series tabs/ solder tags.	Solder tags.
Max. Rating:		10A. 250V.	10A. 250V.	6.3A. 250V.
Max. Power Dissipation:		4W. (@ 23°C).	4W. (@ 23°C).	2.5W. (@ 23°C).
Insulation Resistance:		>10 ² MΩ @ 500V d.c.	>10 ² MΩ @ 500V d.c.	>10 ³ MΩ @ 500V d.c.
A.C. Breakdown:		5kV @ 50Hz.	5kV @ 50Hz.	6kV @ 50Hz.
Contact Resistance:		<10mΩ.	<10mΩ.	<10mΩ.
Mouldings:		Body: Polyester. Cap: Nylon. Nut: Glass Filled Nylon.	Body: Polyester. Cap: Nylon. Nut: Glass Filled Nylon.	Body and Nut: Glass Filled Nylon. Cap: Nylon.
Contacts:		Brass, Silver Plated.	Brass, Silver Plated.	Brass, Silver Plated.
Approvals:		Ⓢ (FX0354 only).	Ⓢ	Ⓢ
Accessories:		PNo.11327 and 12298 (see page 152)	PNos 11327 and 12297 (see page 152)	PNos. 11327 (see page 152)

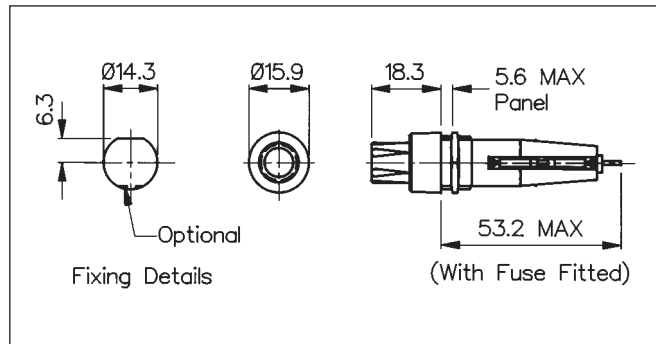
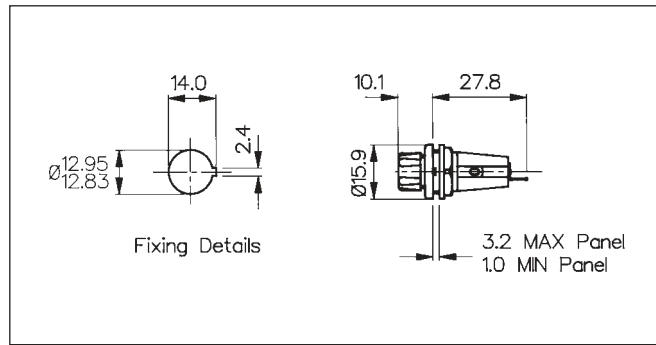
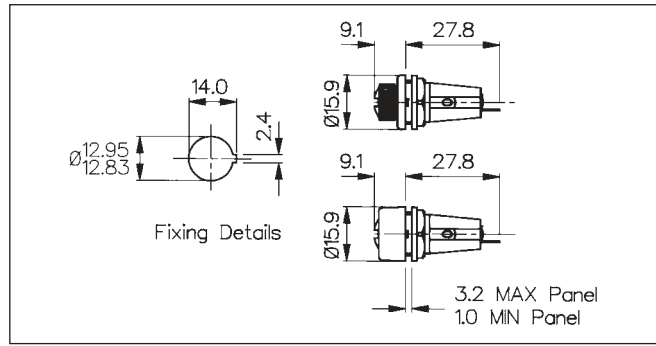

FUSE HOLDERS



Data	List No.	FX0296, FX0296/S	FX0296/1	DF0727/VOLTAGE/COLOUR
Fuse Size:		5 x 20	5 x 20	5 x 20
Fuse Carrier:		FX0296 Screw cap, hand release. FX0296/ S Screw cap, screwdriver release.	Screw cap, hand release.	Screw cap, hand release.
Terminations:		Solder tags. 2.8 series tabs - details on request.	Solder tags. 2.8 series tabs - details on request.	Solder tags.
Max. Rating:		6.3A. 250V.	6.3A. 250V.	6.3A. 250V.
Max. Power Dissipation:		2.5W. (@ 23°C).	2.5W. (@ 23°C).	2.5W. (@ 23°C).
Insulation Resistance:		>10 ⁵ MΩ @ 500V d.c.	>10 ⁵ MΩ @ 500V d.c.	>10 ⁴ MΩ @ 500V d.c.
A.C. Breakdown:		2.5kV @ 50Hz.	2.5kV @ 50Hz.	6kV @ 50Hz.
Contact Resistance:		<5mΩ.	<5mΩ.	<10mΩ.
Mouldings:		Body and Nut: Glass Filled Nylon. Cap: Nylon.	Body and Nut: Glass Filled Nylon. Cap: Nylon.	Lens: Polycarbonate. Body and Cap: Glass Filled Nylon. Spacer: Nylon.
Contacts:		Brass, Silver or Tin Plated.	Brass, Silver or Tin Plated.	Brass, Silver Plated.
Accessories:		PNo.9820 (see page 152)	PNo.9820 (see page 152)	PNo.12932 (see page 152)
Ordering Details:				Clear lens/ WC (red/ RD to agreed orders). Neon voltage/ 110V (105-125V) or / 250V (200-250V) please state when ordering.



Panel Mounting Sealed to IP66 PC1*

* See Page 140

FUSEHOLDERS



FX0345



FX0365

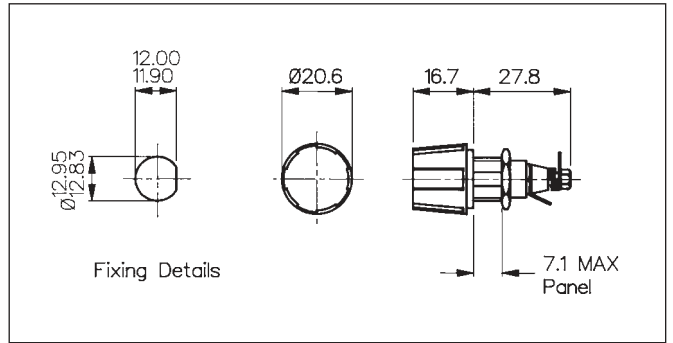
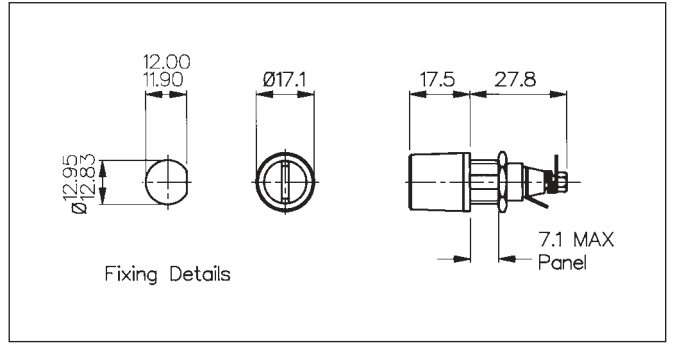

Data	List No.	FX0345, FX0345/A	FX0365, FX0365/A
Fuse Size:		5 x 20	5 x 20
Fuse Carrier:		Screw cap, screwdriver release.	Screw cap, hand release. Large ribbed cap allows removal with gloved hand.
Terminations:		Solder tags.	Solder tags.
Max. Rating:		6.3A. 250V.	6.3A. 250V.
Max. Power Dissipation:		4W (@23°C).	4W (@23°C).
Insulation Resistance:		>10 ³ MΩ @ 500V d.c.	>10 ³ MΩ @ 500V d.c.
A.C. Breakdown:		3.5kV @ 50Hz.	3.5kV @ 50Hz.
Contact Resistance:		<10mΩ.	<10mΩ.
Mouldings:		Body, Cap and Spacer: Glass Filled Nylon. Insulating Sleeve: Nylon.	Body, Cap and Spacer: Glass Filled Nylon. Insulating Sleeve: Nylon.
Contacts:		Brass, Tin Plated.	Brass, Tin Plated.
Sealing:		Protection Classification: IP66 to BS5490: 1977. Retains sealing integrity with cap removed since they are both panel and barrier sealed.	
Notes:		See page 155 for FX0269 Fuses. FX0345/A. Defence Standard 59-100 part 1, issue 2, Section B. NSN 5920-99-784-7741.	See page 155 for FX0269 Fuses. FX0365/A. Defence Standard 59-100 part 1, issue 2, Section B. NSN 5920-99-762-7483.

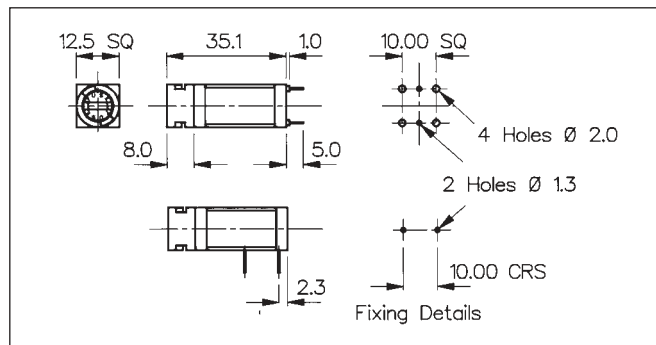
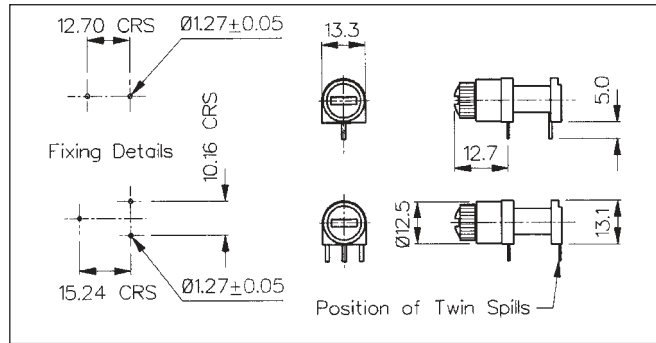
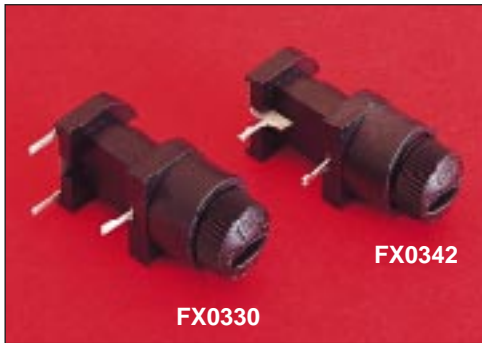

FUSE HOLDERS



Data	List No.	FX0330, FX0342	FX0456, FX0457
Fuse Size:		5 x 20	5 x 20
Fuse Carrier:		Screw cap, hand release.	Bayonet cap, screwdriver release.
Terminations:		FX0330 3 P.C. Spills FX0342 2 P.C. Spills	P.C. spills
Max. Rating:		6.3A. 250V.	10A. 250V.
Max. Power Dissipation:		2.5W (@23°C).	2.5W (@23°C).
Insulation Resistance:		>10 ⁴ MΩ @ 500V d.c.	>10 ² MΩ @ 500V d.c.
A.C. Breakdown:		6kV @ 50Hz.	4kV @ 50Hz.
Contact Resistance:		<5mΩ.	<10mΩ.
Mouldings:		Body: Glass Filled Nylon. Cap: Nylon.	Body: Polyester. Cap and End Bung: Nylon.
Contacts:		Brass, Tin Plated.	Brass, Silver Plated.
Protection Category:		PC1*	PC2*
Approvals:			
Accessories:			



* See Page 140

FUSE HOLDERS

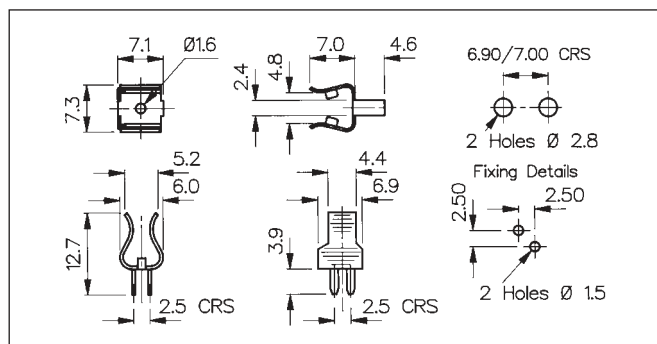
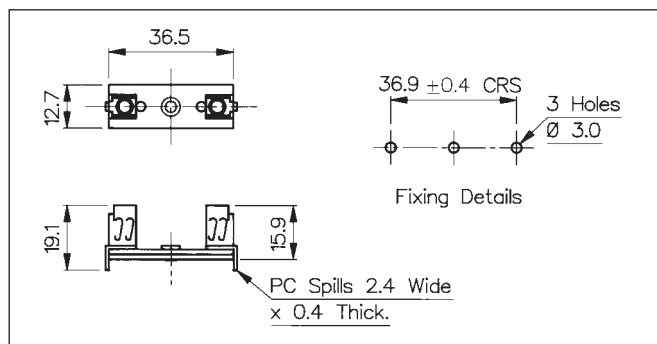
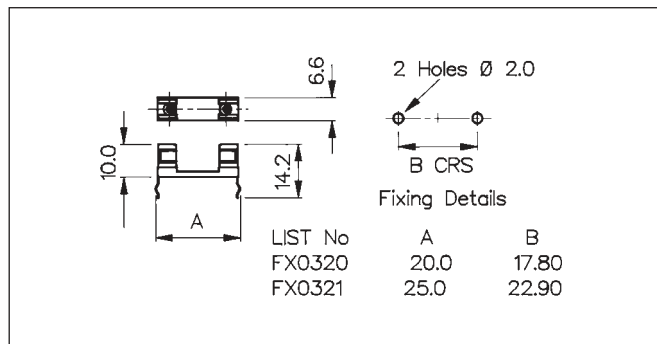

Data \ List No.	FX0321	FX0320	FX0027/PC	P.No.12307/F	P.No.8963/4/U
Fuse Size:	5 x 20	4.7 x 16	6.3 x 32	\varnothing 5mm	\varnothing 6.3mm
Terminations:	P.C. Spills	P.C. Spills	P.C. Spills	P.C. Spills	P.C. Spills
Max. Rating:	6.3A. 250V.	5A. 250V.	7.5A. 250V.	5A. 250V.	5A. 250V.
Insulation Resistance:	$>10^5$ M Ω @ 500V d.c.	$>10^5$ M Ω @ 500V d.c.	$>10^5$ M Ω @ 500V d.c.		
A.C. Breakdown:	7kV clip to clip @ 50Hz.	7kV clip to clip @ 50Hz.	1kV @ 50Hz.		
Contact Resistance:	<10m Ω .	<10m Ω .	<5m Ω .	<5m Ω .	<5m Ω .
Base Material:	Glass Filled Nylon.	S.R.B.P.	S.R.B.P.		
Contacts:	Phosphor Bronze, Tin Plated.	Phosphor Bronze, Tin Plated.	Clips: Phosphor Bronze, Tin Plated. Tabs: Brass, Tin Plated.	Brass, Tin Plated.	Phosphor Bronze, Tin Plated.
				Note: Fuse not supplied.	Note: Fuse not supplied.
Accessories:	P.No. 12760 (see page 152)				

* See Page 140

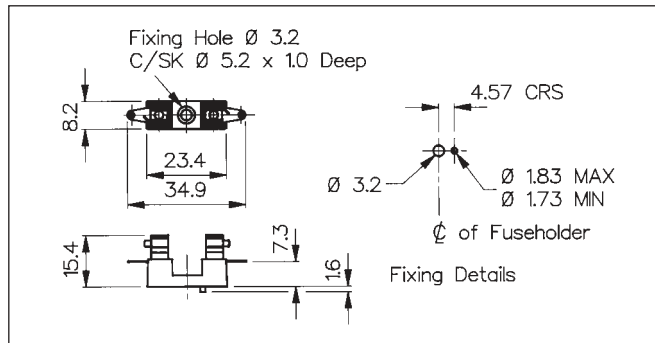
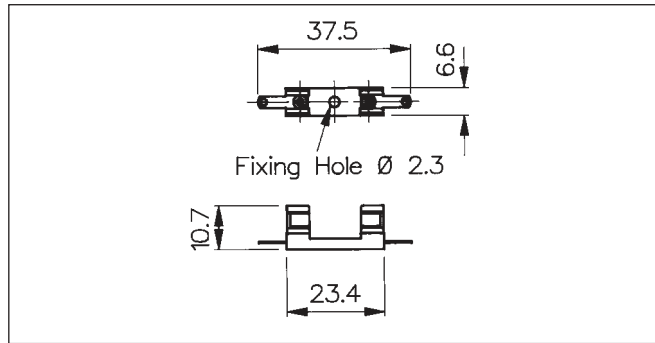
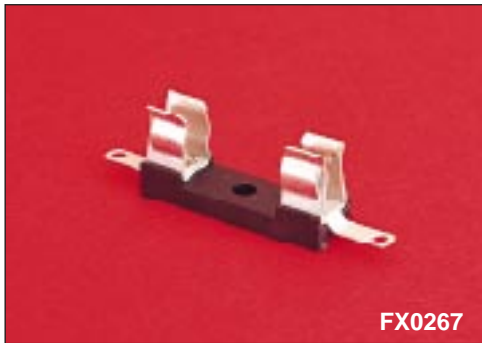

FUSE HOLDERS



Data	List No.	FX0267	FX0360	
Fuse Size:		5 x 20	5 x 20	
Terminations:		Solder tags.	Solder tags.	
Max. Rating:		6.3A. 250V.	6.3A. 250V.	
Insulation Resistance:		>10 ⁵ MΩ @ 500V d.c.	>10 ⁴ MΩ @ 500V d.c.	
A.C. Breakdown:		1.5kV @ 50Hz.	2kV @ 50Hz.	
Contact Resistance:		<10mΩ.	<10mΩ.	
Base Material:		Glass Filled Nylon.	Glass Filled Nylon.	
Contacts:		Phosphor Bronze, Tin Plated.	Phosphor Bronze, Tin Plated.	
Accessories:		PNo.12760 (see page 152)		



* See Page 140

FUSE HOLDERS

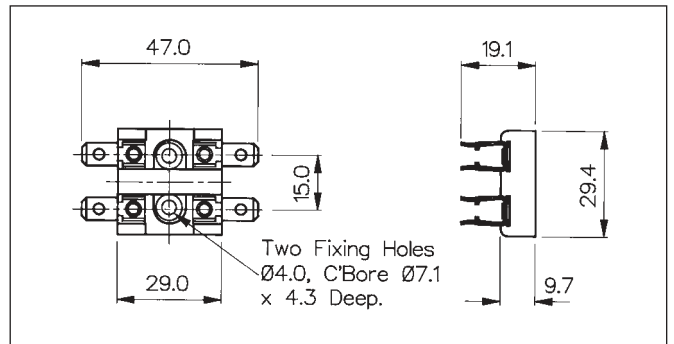
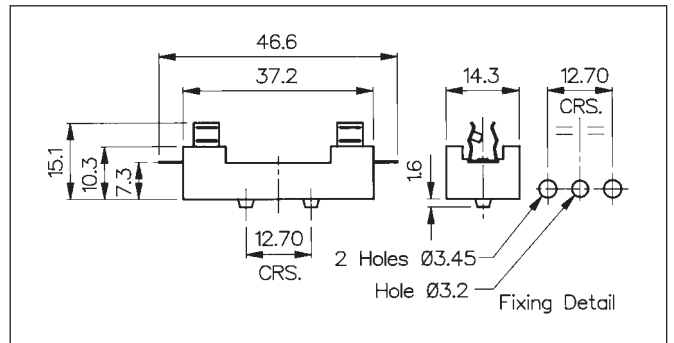
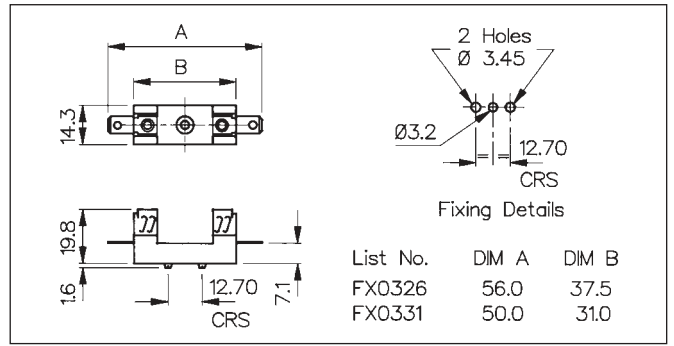
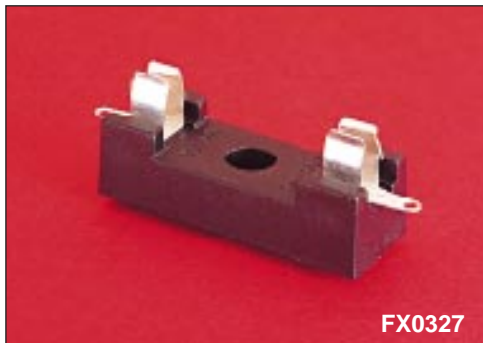
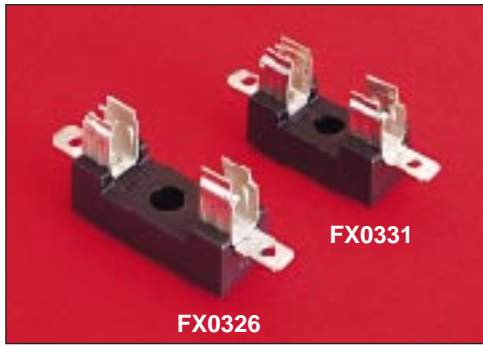

Data	List No.	FX0326	FX0331	FX0327	FX0340
Fuse Size:		6.3 x 32	6.3 x 25	6.3 x 32	6.3 x 25
Terminations:		6.3 series tabs.		Solder tags.	6.3 series tabs.
Max. Rating:		13A. 250V.		5A. 250V.	13A. 250V.
Insulation Resistance:		>10 ⁴ MΩ @ 500V d.c.		>10 ⁵ MΩ @ 500V d.c.	>10 ⁴ MΩ @ 500V d.c.
A.C. Breakdown:		5kV @ 50Hz.		5kV @ 50Hz.	5kV @ 50Hz.
Contact Resistance:		<5mΩ.		<10mΩ.	<5mΩ.
Base Material:		Glass Filled Polyester.		Glass Filled Polyester.	Phenolic.
Contacts:		Clips: Phosphor Bronze, Tin Plated. Tabs: Brass, Tin Plated.		Phosphor Bronze, Tin Plated.	Clips: Phosphor Bronze, Tin Plated. Tabs: Brass, Tin Plated.



& In-Line Fuseholders Sealed to IP66 (PC1)*

* See Page 140

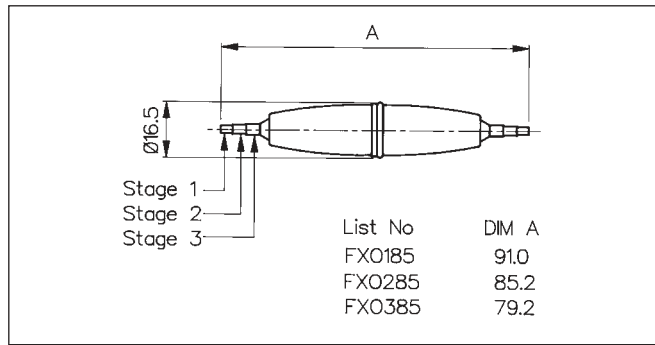
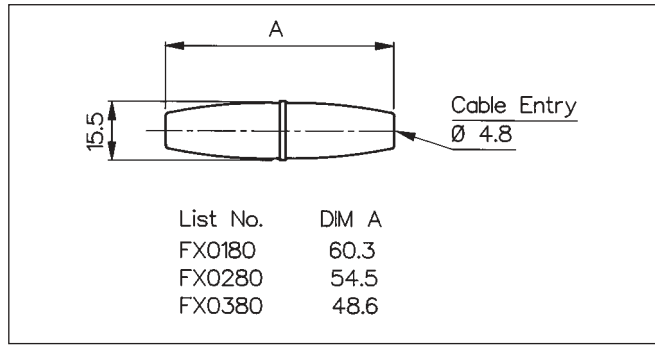

FUSEHOLDERS



Data	List No.	FX0180, FX0280, FX0380	FX0185, FX0285, FX0385
Fuse Size:		5 x 20 6.3 x 25 to BS 1362 6.3 x 32	FX0380 FX0280 FX0180
Fuse Size:			5 x 20 6.3 x 25 to BS 1362 6.3 x 32
Fuse Size:			FX0385 FX0285 FX0185
Cable Acceptance:		1mm ² conductor (max)	1mm to 2.64mm overall diameter. Stage 1: 1.00mm to 1.40mm. Stage 2: 1.50mm to 1.90mm. Stage 3: 2.00mm to 2.64mm. 1mm ² conductor (max.).
Terminations:		Screw terminal (solder to order).	Screw terminal.
Max. Rating:		10A. 50V. (250V where inaccessible inside equipment)	10A. 50V. (250V where inaccessible inside equipment)
Insulation Resistance:		>10 ⁵ MΩ @ 500V d.c.	>10 ⁵ MΩ @ 500V d.c.
High Voltage Proof Test:		2kV (50Hz for 1 minute).	2kV (50Hz for 1 minute).
Contact Resistance:		<10mΩ.	<10mΩ.
Operating Temp.:		-20°C to +90°C.	-20°C to +70°C.
Sealing:			Protection Classification: IP66 BS60529: 1992
Mouldings:		Body: Polybutene.	Body Moulding: Polybutene. Grommet: PVC. 'O' Ring: Nitrile.
Contacts:		Terminals: Brass, Nickel Plated. Grub Screw: Steel, Zinc Plated.	Terminals: Brass, Nickel Plated. Grub Screw: Steel, Zinc Plated.

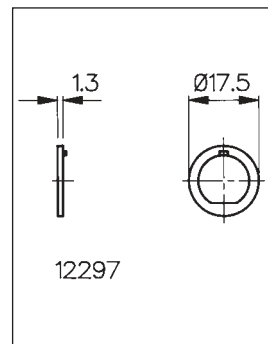
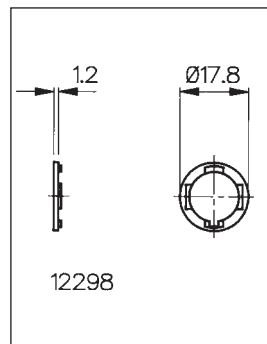
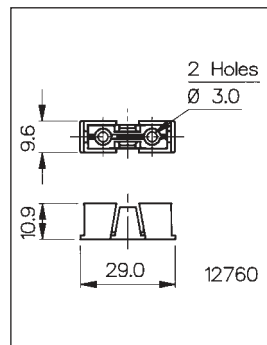
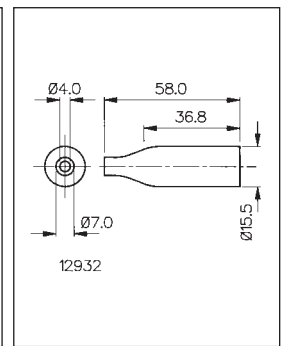
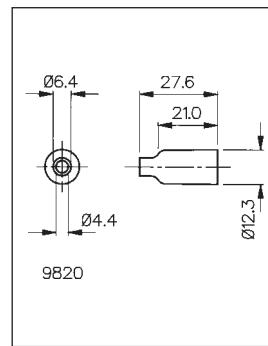
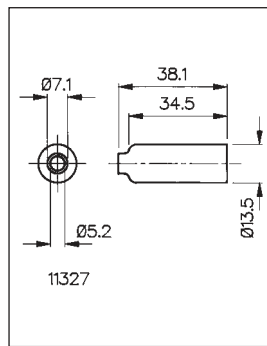

Accessories	For Use With:
P.No. 9820 (Boot)	FX0296, FX0296/ 1, FX0296/ S.
P.No. 11327 (Boot)	FX0354, FX0354/ S, FX0355, FX0357, FX0359, FX0396, FX0396/ 1, FX0454, FX0454/ S, FX0455, FX0455/ S, FX0460.
P.No. 12932 (Boot)	FX0415, FX0415/ S, FX0416, FX0416/ S, DF0727.
P.No. 12760 (Cover)	FX0267, FX0321.
Max. Working Voltage:	250V a.c.
Flash Tested to:	2kV a.c.
Material:	PNos. 9820, 11327, 12932: PVC. PNo. 12760: Polycarbonate.
P.No. 12297 (Adaptor Washer)	Adapts "D" Fixing to anti-rotation Key Fixing. FX0455, FX0455/ S, FX0355.
P.No. 12298 (Adaptor Washer)	Adapts anti-rotation Keyed Fixing to double "D" hole Ø16. FX0454, FX0454/ S, FX0354, FX0354/ S.
Material:	Glass Filled Nylon.



Fuses 5 x 20 mm

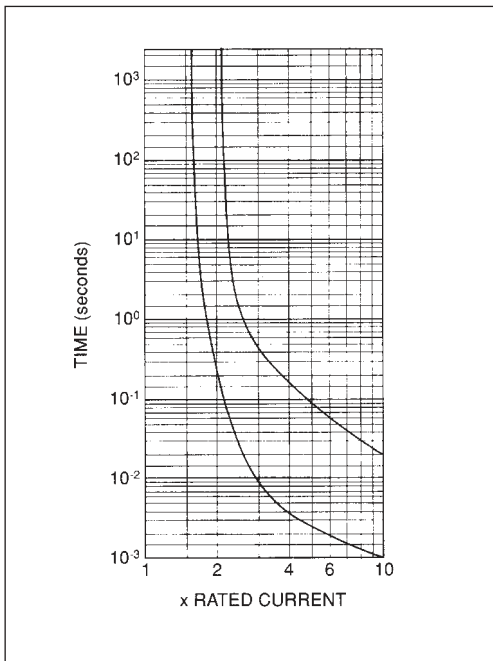

FX0370

FX0370/Rating: Approvals: BSI

Glass, Quick Acting F, low breaking capacity. Conforms to EN60 127-2, Sheet 2.

Breaking Capacity: 35A or 10 I_n (whichever is greater) @ cos φ = 1 @ 250V.

Voltage Rating: 250V. a.c.

Endurance: Cycling test as specified in EN60 127, followed by 1 Hour @ 1.5 I_n.

Ambient Temperature: IEC/BS specifies 15°C to 35°C. FX0370 up to and including 70°C without derating.

Note: Rated Current (I_n). The current that a fuse will carry continuously without deterioration.

FUSES

Performance Data



Current	Total Operating Time		Rating
	Min.	Max.	
1.5 I _n	60min		All Ratings
2.1 I _n	-	30min	All Ratings
2.75 I _n	10ms	500ms	32-100mA
2.75 I _n	50ms	2s	125mA-6.3A
4 I _n	3ms	100ms	32-100mA
4 I _n	10ms	300ms	125mA-6.3A
10 I _n	-	20ms	32-100mA
10 I _n	-	20ms	125mA-6.3A

Current Ratings			
32mA	125mA	500mA	2A
40mA	160mA	630mA	2.5A
50mA	200mA	800mA	3.15A
63mA	250mA	1A	4A
80mA	315mA	1.25A	5A
100mA	400mA	1.6A	6.3A

Fuses 5 x 20 mm

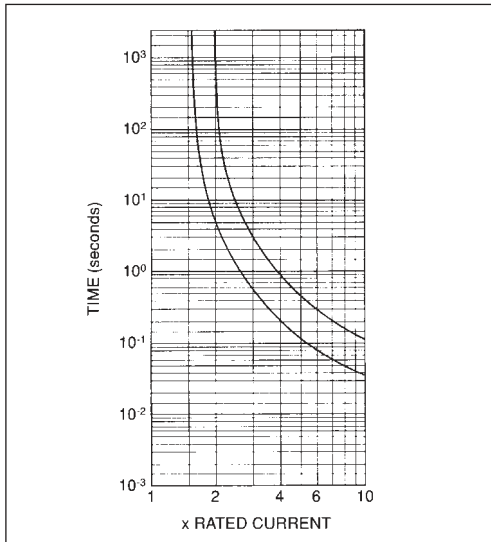

FX0287

FX0287/Rating.

Approvals: BSI

Glass, Time Delay T, anti-surge, low breaking capacity.

Construction: Spiral element wound on fibreglass core. Conforms to EN60 127-2, Sheet 3.

Breaking Capacity: 35A or 10 I_n (whichever is greater)
@ $\cos \phi = 1$ @ 250V.

Voltage Rating: 250V. a.c.

Endurance: Cycling test as specified in EN60 127, followed by 1 Hour @ 1.5 I_n .

Ambient Temperature: IEC/BS specifies 15°C to 35°C. FX0287 up to and including 70°C without derating.

Note: Rated Current (I_n). The current that a fuse will carry continuously without deterioration.

Performance Data

Current	Total Operating Time		Rating
	Min.	Max.	
1.5 I_n	60min	-	All Ratings
2.1 I_n	-	2min	All Ratings
2.75 I_n	200ms	10s	32-100mA
2.75 I_n	600ms	10s	125mA-6.3A
4 I_n	40ms	3s	32-100mA
4 I_n	150ms	3s	125mA-6.3A
10 I_n	10ms	300ms	32-100mA
10 I_n	20ms	300ms	125mA-6.3A

Current Ratings			
32mA	80mA	200mA	500mA
40mA	100mA	250mA	630mA
50mA	125mA	315mA	Other ratings may be available. Details on request.
63mA	160mA	400mA	



Fuses 5 x 20 mm

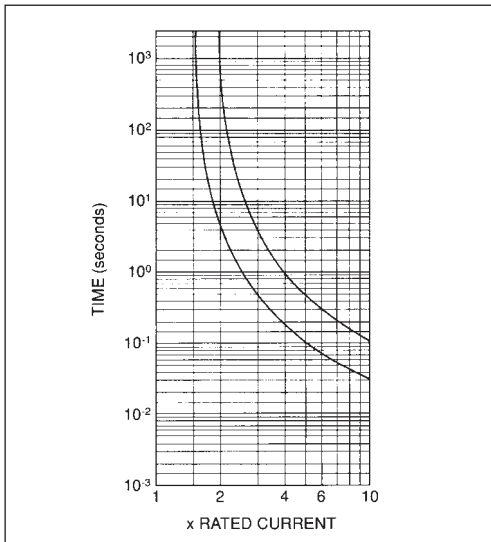

FX0288

FX0288/Rating: Approvals: BSI

Glass, Time Delay T, anti-surge, low breaking capacity.

Construction: M effect plated wire element. Conforms to EN60 127-2, Sheet 3.

Breaking Capacity: 35A or 10 In (whichever is greater) @ cos ϕ = 1 @ 250V.

Voltage Rating: 250V. a.c.

Endurance: Cycling test as specified in EN60 127, followed by 1 Hour @ 1.5 In.

Ambient Temperature: IEC/BS specifies 15°C to 35°C. Above 35°C FX0288 should be derated by 3% per 10°C rise in temperature to max. 70°C.

Note: Rated Current (In). The current that a fuse will carry continuously without deterioration.

Performance Data

Current	Total Operating Time	
	Min.	Max.
1.5 In	60min	-
2.1 In	-	2min
2.75 In	600ms	10s
4 In	150ms	3s
10 In	20ms	300ms

Current Ratings			
800mA	1.6A	3.15A	6.3A
1A	2A	4A	
1.25A	2.5A	5A	

FUSES

Fuses 5 x 20 mm

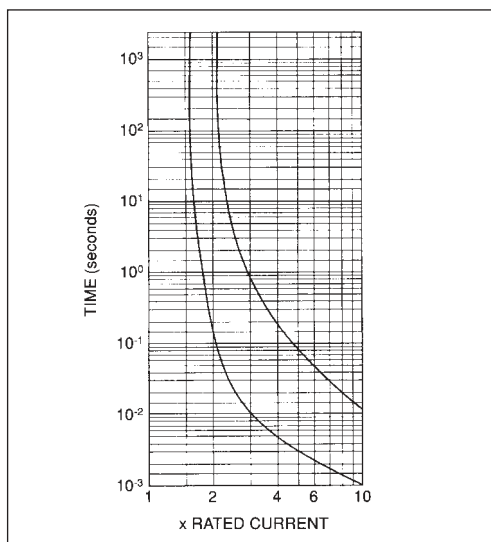

FX0269

FX0269/Rating: Approvals:

Ceramic HRC, Quick Acting F, high breaking capacity. Conforms to EN60 127-2, Sheet I.

Breaking Capacity: 1500A @ 250V a.c. cos ϕ = 0.7 - 0.8 lagging.

Voltage Rating: 250V. a.c.

Endurance: Cycling test as specified in EN60 127, followed by 1 Hour @ 1.5 In.

Ambient Temperature: IEC/BS specifies 15°C to 35°C. FX0269 up to and including 70°C without derating.

Note: Rated Current (In). The current that a fuse will carry continuously without deterioration.



Performance Data

Current	Total Operating Time		Rating
	Min.	Max.	
1.5 In	60min	-	All Ratings
2.1 In	-	30min	All Ratings
2.75 In	10ms	2s	Below 4A
2.75 In	10ms	3s	4A & above
4 In	3ms	300ms	All Ratings
10 In	-	20ms	All Ratings

Current Ratings			
50mA	200mA	800mA	3.15A
63mA	250mA	1A	4A
80mA	315mA	1.25A	5A
100mA	400mA	1.6A	6.3A
125mA	500mA	2A	
160mA	630mA	2.5A	

Fuses 4.7 x 16 mm

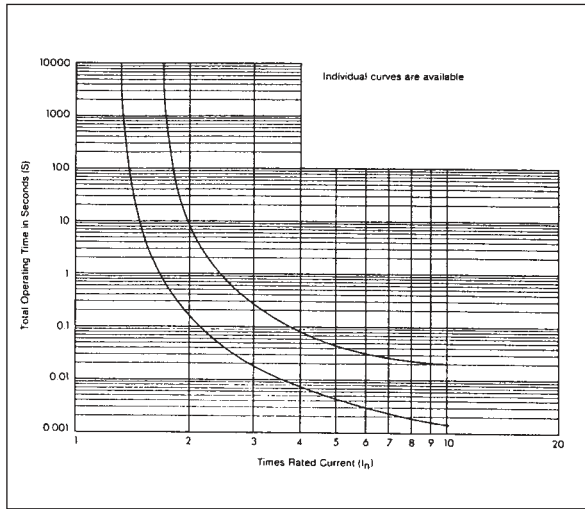

FX0300

FX0300/Rating:

Glass, Quick Acting F, low breaking capacity.

Blowing Time: Within 10 secs @ $2 \times I_n$, instantly after carrying I_n for > 1 min & < 10 min.

Voltage Rating: 250V. a.c. (unless otherwise stated below).

Note: Rated Current (I_n). The current that a fuse will carry continuously without deterioration.

Current Ratings	
500mA	4A
1A	(100V. a.c. MAX.)
1.5A	7A
3A	(32V. a.c./ d.c. MAX.)

Fuses 6.3 x 25 mm

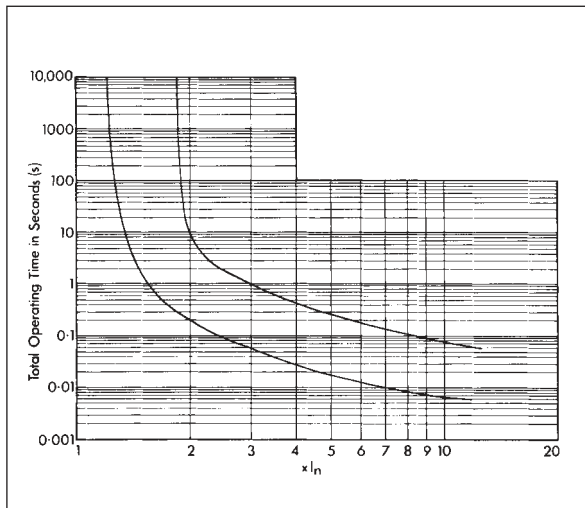

FX0100

FX0100/Rating.

Glass, Quick Acting F, low breaking capacity.

Blowing Time: $2 \times I_n$, clearing within 10s.

Voltage Rating: See table.

Note: Rated Current (I_n). The current that a fuse will carry continuously without deterioration.

Performance Data

Current	Total Operating Time	
	Min.	Max.
$2 I_n$	-	10s

Current Ratings	
5.0A	(200V)
15.0A	(40V)



Fuses 6.3 x 32mm

Performance Data

Current	Total Operating Time	
	Min.	Max.
2.1 I _n	-	10s

Rating	Volts		Colour Code
	a.c.	d.c.	
60mA	1000	1000	Black
100mA	1000	1000	Grey
150mA	1000	1000	Red
250mA	1000	750	Brown
500mA	750	350	Yellow
750mA	500	300	Green
1.0A	350	250	Dark Blue
1.5A	250	250	Light Blue
2.0A	250	250	Purple
3.0A	250	32	White
5.0A	250	32	Black & White
7.0A	150	32	Light Orange
10.0A	100	32	Light Orange & Black
15.0A	32	32	Light Orange & Green
20.0A	32	32	Light Orange & Violet
25.0A	32	32	Light Orange & White

FX0120

FX0120/Rating:

Glass, Quick Acting F, low breaking capacity.

Breaking Capacity: 10I_n @ rated voltage. Conforms to BS2950A.

Voltage Rating: See table.

Endurance: 1000 hours minimum @ I_n.

Note: Rated Current (I_n). The current that a fuse will carry continuously without deterioration.

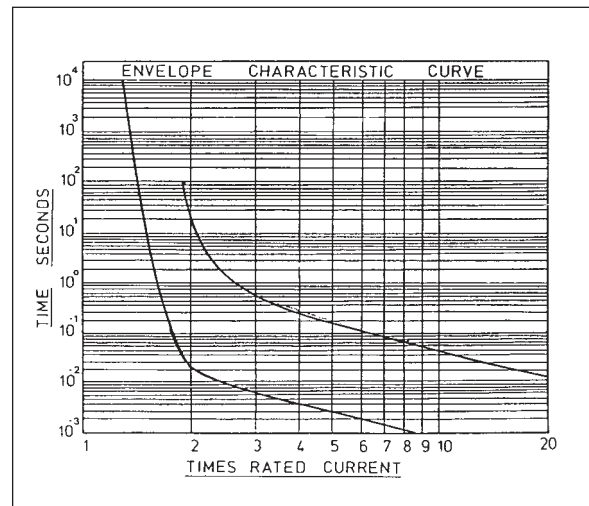

FUSES

Fuses 6.3 x 32mm

Performance Data

Current	Total Operating Time		Rating
	Min.	Max.	
2 I _n	-	10s	All Ratings
10 I _n	10ms	-	All Ratings

FX0283

FX0283/Rating:

Glass Time Delay T, low breaking capacity.

Breaking Capacity: 10 I_n @ rated voltage.

Voltage Rating: See table.

Endurance: 1000 hours minimum @ I_n.

Note: Rated Current (I_n). The current that a fuse will carry continuously without deterioration.

Rating	Volts	
	a.c.	d.c.
100mA	1000	1000
150mA	1000	1000
250mA	1000	750
500mA	750	350
750mA	500	300
1.0A	350	250
1.5A	250	250
2.0A	250	250
3.0A	250	32
5.0A	250	32
7.0A	150	32
10.0A	100	32

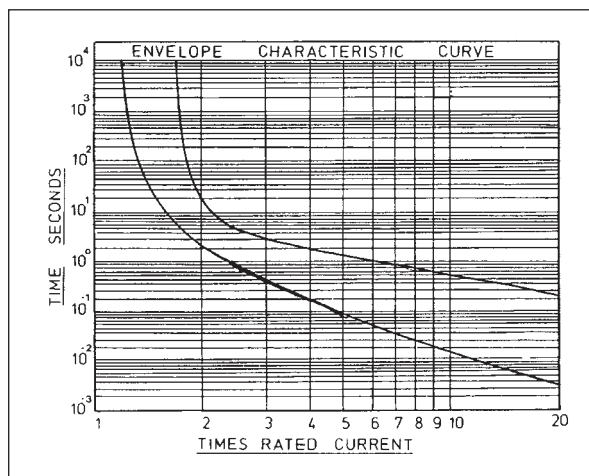

Fuses Miniature P.C. Mounting

FX0301

FX0301/Rating:

Glass, Quick Acting F, low breaking capacity.

Blowing Time: Within 10 secs @ $2 \times I_n$, instantly after carrying I_n for > 1 min & < 10 min.

Voltage Rating: 250V. a.c. (unless otherwise stated below).

Note: Rated Current (I_n). The current that a fuse will carry continuously without deterioration.

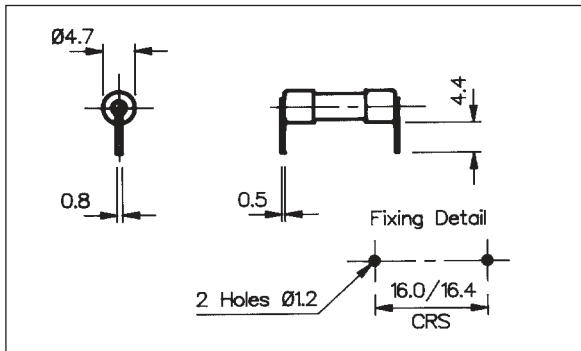
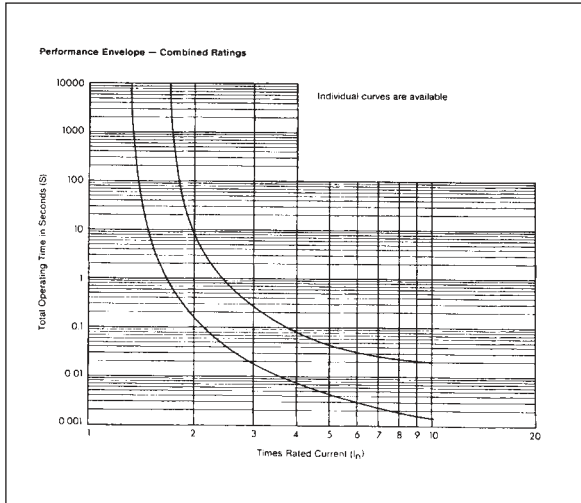

Current Ratings		
60mA	500mA	4A (100V a.c. MAX.)
100mA	750mA	
250mA	1A	