

2-speed 3-phase motor starter, Size 3 1/2, One winding consequent pole, Constant or variable torque, Solid-state overload relays, Low Spd OLR range 50-200A, High Spd OLR range 50-200A, Enclosure NEMA type 1, Indoor general purpose use



product brand name	Class 30
design of the product	Full-voltage two speed motor starter
special product feature	ESP200 overload relay; Half-size controller; Dual voltage coil
<b>General technical data</b>	
weight [lb]	70 lb
Height x Width x Depth [in]	29 × 23 × 9 in
touch protection against electrical shock	NA for enclosed products
installation altitude [ft] at height above sea level maximum	6560 ft
ambient temperature [°F]	
• during storage	-22 ... +149 °F
• during operation	-4 ... +104 °F
ambient temperature	
• during storage	-30 ... +65 °C
• during operation	-20 ... +40 °C
country of origin	USA
<b>Horsepower ratings</b>	
yielded mechanical performance [hp] for 3-phase AC motor	
• at 200/208 V rated value	30 hp
• at 220/230 V rated value	40 hp
• at 460/480 V rated value	75 hp
• at 575/600 V rated value	75 hp
<b>Contactors</b>	
size of contactor	Controller half size 3 1/2
number of NO contacts for main contacts	6
operating voltage for main current circuit at AC at 60 Hz maximum	600 V
operational current at AC at 600 V rated value	115 A
mechanical service life (operating cycles) of the main contacts typical	5000000
<b>Auxiliary contact</b>	
number of NC contacts at contactor for auxiliary contacts	2
number of NO contacts at contactor for auxiliary contacts	2
number of total auxiliary contacts maximum	7
contact rating of auxiliary contacts of contactor according to UL	10A@600VAC (A600), 2.5A@300VDC (Q300)
<b>Coil</b>	
type of voltage of the control supply voltage	AC
control supply voltage	
• at AC at 60 Hz rated value	110 ... 240 V
holding power at AC minimum	28 W
apparent pick-up power of magnet coil at AC	620 VA
apparent holding power of magnet coil at AC	52 VA

operating range factor control supply voltage rated value of magnet coil	0 ... 1
percentual drop-out voltage of magnet coil related to the input voltage	50 %
ON-delay time	26 ... 41 ms
OFF-delay time	14 ... 19 ms

### Overload relay

product function	
<ul style="list-style-type: none"> <li>• overload protection</li> <li>• phase failure detection</li> <li>• asymmetry detection</li> <li>• ground fault detection</li> <li>• test function</li> <li>• external reset</li> </ul>	<ul style="list-style-type: none"> <li>Yes</li> <li>Yes</li> <li>Yes</li> <li>Yes</li> <li>Yes</li> <li>Yes</li> </ul>
reset function	Manual, automatic and remote
trip class	CLASS 5 / 10 / 20 (factory set) / 30
adjustable current response value current of overload relay	
<ul style="list-style-type: none"> <li>• for low rotational speed</li> <li>• for high rotational speed</li> </ul>	<ul style="list-style-type: none"> <li>50 ... 200 A</li> <li>50 ... 200 A</li> </ul>
tripping time at phase-loss maximum	3 s
relative repeat accuracy	1 %
product feature protective coating on printed-circuit board	Yes
number of NC contacts of auxiliary contacts of overload relay	1
number of NO contacts of auxiliary contacts of overload relay	1
operational current of auxiliary contacts of overload relay	
<ul style="list-style-type: none"> <li>• at AC at 600 V</li> <li>• at DC at 250 V</li> </ul>	<ul style="list-style-type: none"> <li>5 A</li> <li>1 A</li> </ul>
contact rating of auxiliary contacts of overload relay according to UL	5
insulation voltage (Ui)	
<ul style="list-style-type: none"> <li>• with single-phase operation at AC rated value</li> <li>• with multi-phase operation at AC rated value</li> </ul>	<ul style="list-style-type: none"> <li>600 V</li> <li>300 V</li> </ul>

### Enclosure

design of the housing	indoors, usable on a general basis
-----------------------	------------------------------------

### Mounting/wiring

mounting position	vertical
fastening method	Surface mounting and installation
type of electrical connection for supply voltage line-side	Box lug
tightening torque [lbf-in] for supply	120 ... 120 lbf-in
type of connectable conductor cross-sections at line-side for AWG cables single or multi-stranded	1
temperature of the conductor for supply maximum permissible	75 °C
material of the conductor for supply	AL or CU
type of electrical connection for load-side outgoing feeder	Box lug
tightening torque [lbf-in] for load-side outgoing feeder	120 ... 120 lbf-in
type of connectable conductor cross-sections for AWG cables for load-side outgoing feeder single or multi-stranded	1
temperature of the conductor for load-side outgoing feeder maximum permissible	75 °C
material of the conductor for load-side outgoing feeder	AL or CU
type of electrical connection of magnet coil	Screw-type terminals
tightening torque [lbf-in] at magnet coil	5 ... 12 lbf-in
type of connectable conductor cross-sections of magnet coil for AWG cables single or multi-stranded	2
temperature of the conductor at magnet coil maximum permissible	75 °C
material of the conductor at magnet coil	CU
type of electrical connection for auxiliary contacts	Screw-type terminals
tightening torque [lbf-in] at contactor for auxiliary contacts	10 ... 15 lbf-in
type of connectable conductor cross-sections at contactor for AWG cables for auxiliary contacts single or multi-stranded	1
temperature of the conductor at contactor for auxiliary contacts maximum permissible	75 °C
material of the conductor at contactor for auxiliary contacts	CU

type of electrical connection at overload relay for auxiliary contacts	Screw-type terminals
tightening torque [lbf-in] at overload relay for auxiliary contacts	7 ... 10 lbf-in
type of connectable conductor cross-sections at overload relay for AWG cables for auxiliary contacts single or multi-stranded	2
temperature of the conductor at overload relay for auxiliary contacts maximum permissible	75 °C
material of the conductor at overload relay for auxiliary contacts	CU

**Short-circuit current rating**

design of the fuse link for short-circuit protection of the main circuit required	10
design of the short-circuit trip	Thermal magnetic circuit breaker
maximum short-circuit current breaking capacity (I <sub>cu</sub> )	
• at 240 V	14 kA
• at 480 V	10 kA
• at 600 V	10 kA
certificate of suitability	NEMA ICS 2; UL 508; CSA 22.2, No.14

**Further information**

Industrial Controls - Product Overview (Catalogs, Brochures,...)

[www.usa.siemens.com/ccatalog](http://www.usa.siemens.com/ccatalog)

Industry Mall (Online ordering system)

<https://mall.industry.siemens.com/mall/en/us/Catalog/product?mlfb=US2:30IUHH32B2VA>

Service&Support (Manuals, Certificates, Characteristics, FAQs,...)

<https://support.industry.siemens.com/cs/US/en/ps/US2:30IUHH32B2VA>

Image database (product images, 2D dimension drawings, 3D models, device circuit diagrams, EPLAN macros, ...)

[http://www.automation.siemens.com/bilddb/cax\\_de.aspx?mlfb=US2:30IUHH32B2VA&lang=en](http://www.automation.siemens.com/bilddb/cax_de.aspx?mlfb=US2:30IUHH32B2VA&lang=en)

Certificates/approvals

<https://support.industry.siemens.com/cs/US/en/ps/US2:30IUHH32B2VA/certificate>

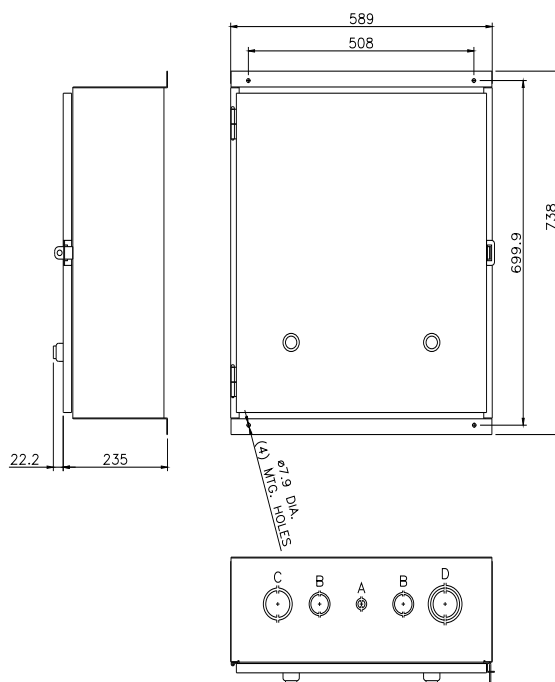

CONDUITS TYP. TOP & BOTTOM

LETTER	CONDUIT SIZE
A	ø12.7 & ø19 DIA. CONDUIT
B	ø31.8 & ø38.1 DIA. CONDUIT
C	ø50.8 & ø63.5 DIA. CONDUIT
D	ø50.8, ø63.5 & ø76.2 DIA. CONDUIT

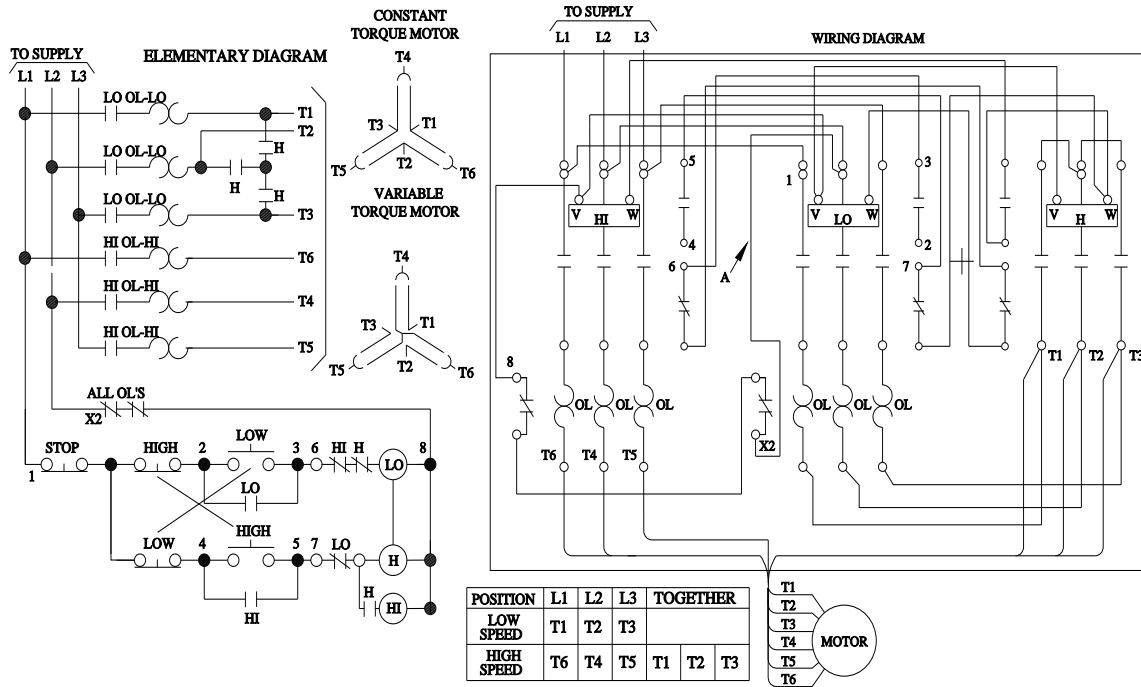

D26434001

last modified:

12/3/2022