

STINGRAY | Magnetic Connector Series



STINGRAY

Magnetic Connector Series

This series offers low profile, compact, sealed connectors that withstand exposure to rain, dust, dirt and chemicals. Stingray connectors are intended for First Responders, Security and Military personnel.

Stingray features a magnetic, non-keyed mating system which allows the connector to be easily mated without the need for pre-alignment and eliminates the need to operate any coupling mechanisms.

Stingray has been optimised for USB 2.0 & Ethernet protocols, and is an excellent solution for audio, power or data signals.

The low profile Stingray connector sits flat against the body to prevent snagging & damage. It is self-aligning due to the strong magnetic connection, and allows customisation and flexibility of cable routing as the cable can be rotated through 360° when the connector is mated.

Features	Benefits
Magnetic mating mechanism	Aids blind-mate performance and prevents inadvertent damage if the user forgets to unmate
Non-keyed rotatable mating	Does not require pre-alignment when mating. Cable exit angle is infinitely variable and can be set and adjusted by the user
Wipe clean interface featuring sprung-loaded contacts	Easy cleaning and decontamination
5000+ mating cycles	Increased connector life before replacement
Compatible with USB 2.0, Ethernet and Audio signal requirements	Allows interconnection of various equipment including computers, radios and headsets
Last mate contact	Allows hot-swapping of equipment and signals (i.e. interface is passive until the connector is fully mated)
90° Cable exit within the height of the connector	Cable runs parallel to the body eliminating loops and preventing snagging
IP68 sealed	High degree of sealing prevents ingress of dust and moisture



Stingray features and terminology

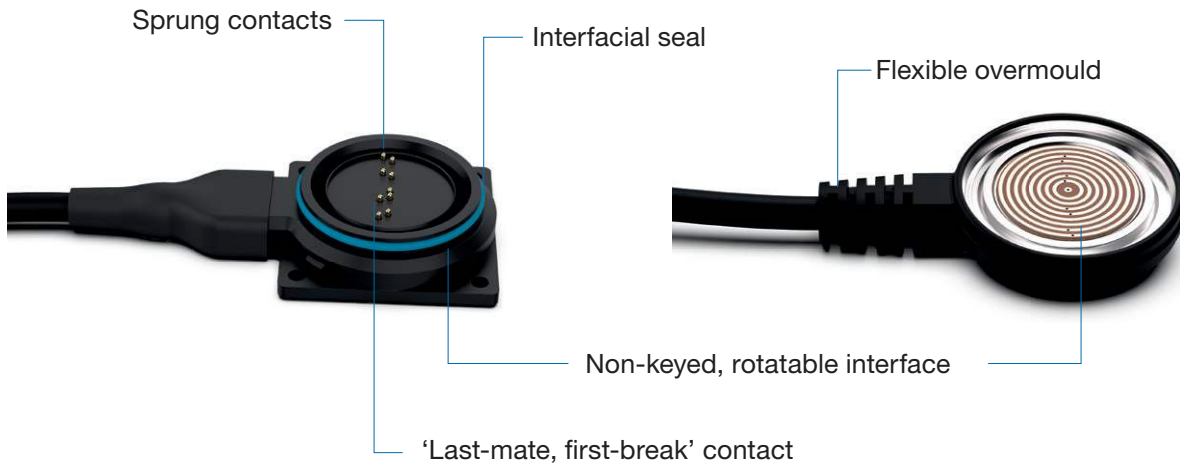

Views of the mated pair



Stingray performance information

Test parameter	Description
Electrical	
Current rating	3A per contact continuous, 5A per contact peak
Data rate	USB 2.0 compliant
Insulation resistance	5000 MΩ at 500 VDC
Contact resistance	<20 mΩ
Environmental	
Sealing	IP68, 1hr at 2 meters immersion
Operating temperature range	-55°C/+85°C
Storage temperature range	-55°C/+125°C
Salt spray	500 hours, 5% NaCl (mated)
RoHS compliant	Yes (dependent on solder used)
Mechanical	
Mating durability	5000 minimum
Shock and vibration	In accordance with DEF-STAN 00-35 Iss 4 Ch2 01 test M1 appendix A figs A22-High Level and A23-Low Level
Separation force, peel	4.0N typical
Rotations	1000 minimum
Rotational torque	0.7Nm typical

Stingray connector part numbering

WM-	XX	XX	XX-	XX-	XXX
Series identifier	Style: 00 = Wall mount receptacle 01 = In-line receptacle 02 = PCB mount receptacle 06 = Plug	Material and finish AU - unplated black thermoplastic	Shell size 03	No. of contacts 09	Variant (omitted for standard item) Consult factory for more details

Please note:
The unplated wall mount receptacle in shell size 3 with 9 contacts is currently available.
The plug connector is only currently available as an overmoulded cable harness.
Further variants are available to order from December 2018.

Stingray part number example

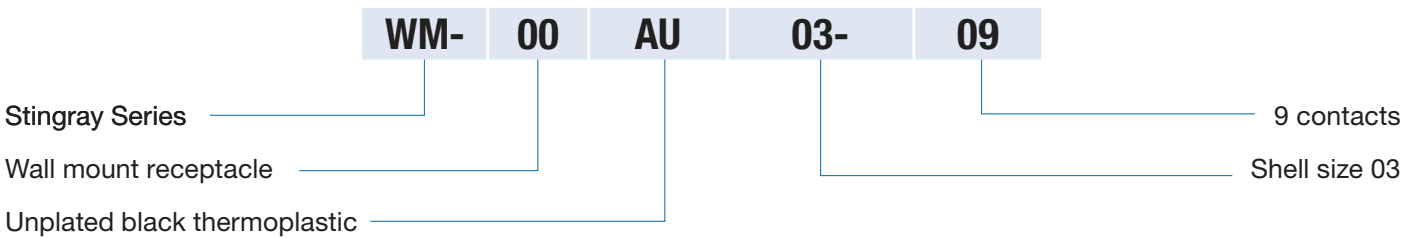

Stingray cable harness part numbering

20GB-WM-	XX	XX	XX-	XX-	XXXX-	XXXX
Series identifier	Style: 00 = Wall mount receptacle 02 = In-line receptacle 06 = Plug	Material and finish: AU - Unplated Black Thermoplastic	Shell size: 03	No. of contacts: 09	Length (mm):	Variant: 0001 = Pig-tail assembly 0002 = Plug to Plug

Please note:
Both the -0001 and -0002 variants use USB 3.0 SuperSpeed cable with high quality improved shielding.
The cable is UL20276, OD:5.5mm with black PVC jacket.

Stingray cable harness part number example

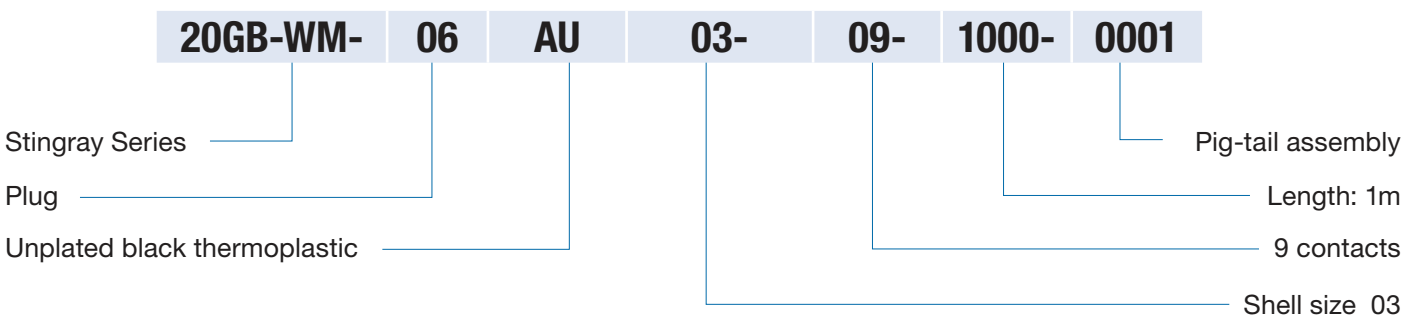

Stingray plug assembly

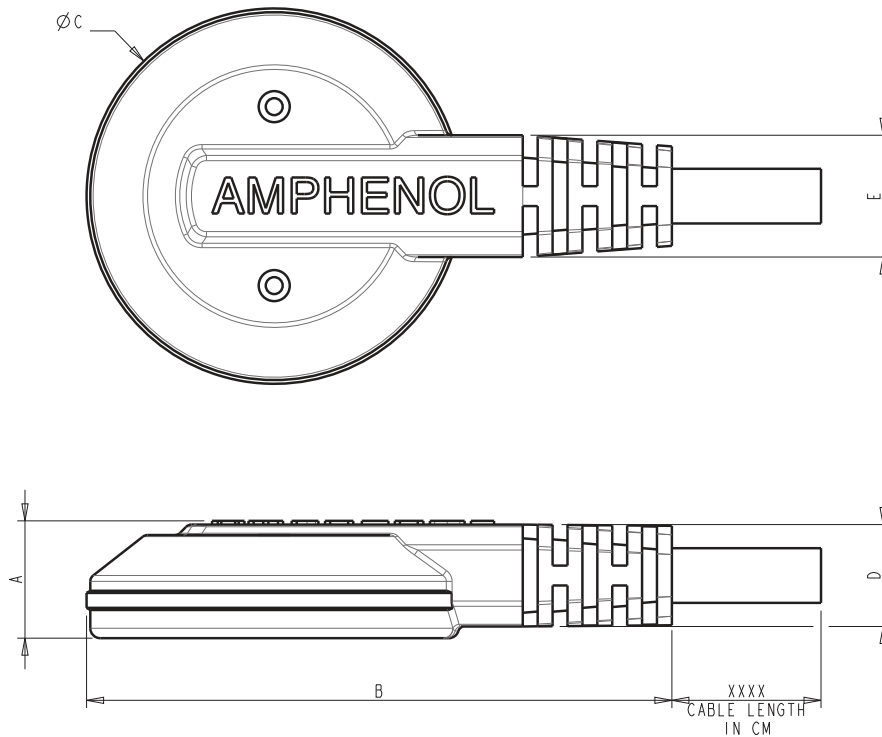

Shell size	A Nom		B Nom		$\varnothing C$ Nom		D Nom		E Nom	
	mm	inch	mm	inch	mm	inch	mm	inch	mm	inch
3	11.99	0.472	59.82	2.355	38.35	1.510	10.41	0.410	12.45	0.490

Please note:
The plug is currently only available as an overmoulded cable harness.
A customer terminated plug is available to order from December 2018.

Stingray plug wiring schematic

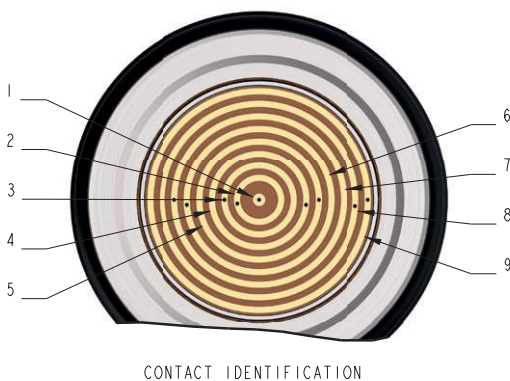

Contact number	USB identification	USB 2.0 connection	Cable colour
1	Power	Yes	Red
2	D-	Yes	White
3	D+	Yes	Green
4	SDP1-	No	Blue
5	SDP1+	No	Yellow
6	SDP2-	No	Purple
7	SDP2+	No	Orange
8	Power GND	Yes	Black
9	GND drain	Yes	Drain

Stingray receptacle

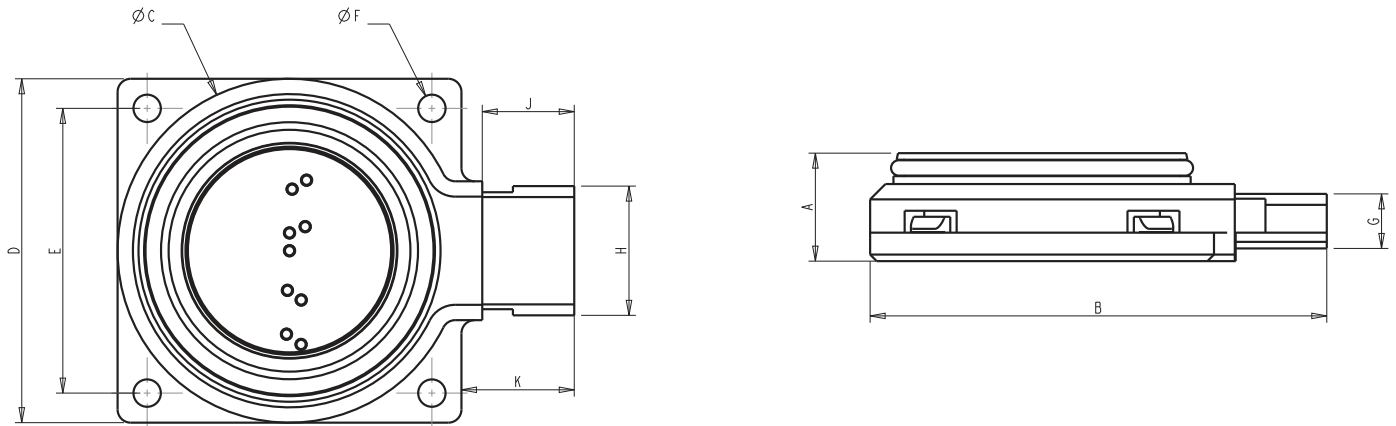

Shell size	A Nom		B Nom		$\varnothing C$ Nom		D Nom		E Nom	
	mm	inch	mm	inch	mm	inch	mm	inch	mm	inch
3	12.52	0.493	52.96	2.085	39.88	1.570	39.88	1.570	33.02	1.300
	$\varnothing F$ Nom		G Nom		H Nom		J Nom		K Nom	
	mm	inch	mm	inch	mm	inch	mm	inch	mm	inch
	3.18	0.125	6.32	0.249	14.99	0.590	10.67	0.420	13.08	0.515

Please note:

An alternative PCB mount receptacle (WM-02) is available to order from December 2018

Stingray receptacle wiring schematic

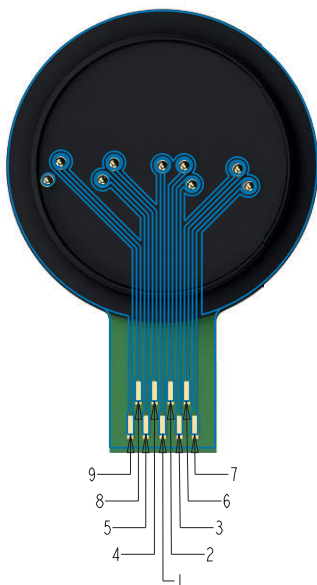

CONTACT IDENTIFICATION

Contact number
1
2
3
4
5
6
7
8
9

USB identification	USB 2.0 connection
Power	Yes
D-	Yes
D+	Yes
SDP1-	No
SDP1+	No
SDP2-	No
SDP2+	No
Power GND	Yes
GND drain	Yes

Stingray receptacle assembly instructions

General assembly instructions are shown below for the Stingray receptacle connector. The receptacle is supplied as three components ready for termination as shown below:

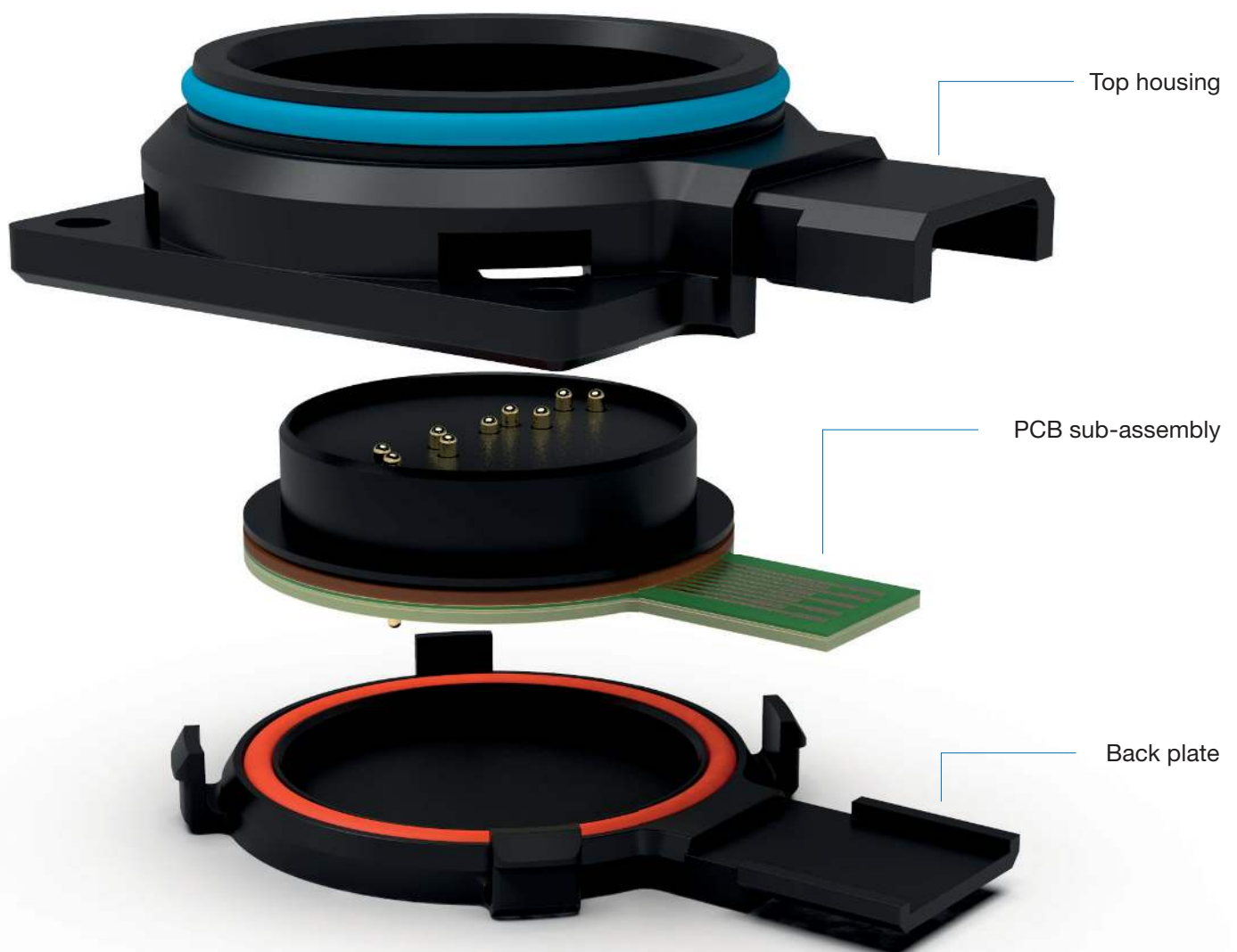

1. Terminate the cable to the PCB sub-assembly in accordance with Amphenol document 123GB-0879.
2. Lightly press the terminated PCB sub-assembly into the top housing.
3. Locate the back plate into the top housing (trapping the terminated PCB sub-assembly) and evenly apply pressure from the rear so that the clips fully engage and 'snap' into position.

Please note that ancillary components have been deleted from the above image for clarity.

Worldwide sales contacts

Europe

Amphenol Ltd, UK
Thanet Way, Whitstable
Kent, CT5 3JF
United Kingdom
T: +44 1227 773 200

Amphenol Socapex, France
948, promenade de l'Arve BP29
74311 Thyez Cedex
France
T: +33 4 50 89 28 00

Amphenol Air LB, France
10 rue champ Raymond
08110 Carignan
France
T: +33 3 24 22 32 70

Amphenol AIR LB GmbH, Germany
Am Kleinbahnhof 4
66740 Saarlouis
Germany
T: +49 6831 981 00

Amphenol Nordic
T: +46 (0)702 3800104

Amphenol Switzerland and South Centre
Switzerland, Slovenia, Serbia, Montenegro, Yugoslavia, Greece, Bulgaria
948, promenade de l'Arve BP29
74311 Thyez Cedex
France
T: +33 4 50 89 28 00

Amphenol Italy
Via Barbaiana n.5
20020 Lainate, Milano
Italy
T: +39 293 254 214

Amphenol Benelux
Zadelmaker 121 NL
2401 PD Alphen aan den Rijn
The Netherlands
T: +31 172 444 903

Amphenol Iberica
Edificio Burgosol, Oficina nr 55
Comunidad de Madrid,
35 bis Las Rozas (Madrid)
Spain
T: +34 91 640 73 06

Amphenol Poland and Central East Europe
Austria, Poland, Czech Republic, Slovakia, Romania
Wiener gasse 68
2380 Perchtoldsdorf
Austria
T: +43 699 10396 071

North America

Amphenol PCD USA
72 Cherry Hill Drive
Beverly, MA. 01915-1065
USA
T: +1 978 624 3400

Amphenol Canada Corporation
605 Milner Avenue
Toronto, Ontario
Canada
M1B 5X6
T: +1 416 291 4401

Asia

Amphenol Daeshin, Korea
558 SongNae-2 Dong, SoSa-Gu,
Bucheon City, Gyeonggi-do
422-040, Korea
T: +82 32 610 3800

Amphenol Interconnect India Private Limited
105 Bhosari Industrial Area
Pune 411 026
India
T: +91 203 068 8304

Amphenol Japan
471-1 Deba, Ritto-City
Shiga 520-3041
Japan
T: +81 77 553 8501

Amphenol PCD CO Ltd, China
Building 21, 1st Liao Keng
Industrial Zone, Shi Yan Street
Bao An District, Shenzhen
518108
China
T: +86 755 8173 8000

Other areas

Amphenol Argentina
Av. Callao 930 2do piso Oficina B
"Plaza" C1023 – AAP, Buenos
Aires
Argentina
T: +54 11 4815 6886

Amphenol Australia Pty Limited
22 Industry Boulevard
Carrum Downs, Victoria 3201
Australia
T: +61 8796 8888

Amphenol Do Brazil
Rua Diogo Moreira
132, 20 andar, rooms 2001-2-3
CEP: 05423 010 Sao Paulo SP
Brazil
T: +55 11 3815 1003

Amphenol Bar-Tec Ltd, Israel
3 Hagavish Street, K fir-Barkan Bldg
East Industrial Zone
Kfar-Sava, 44102
Israel
T: +972 9 764 4100

Amphenol Mexico
Prolongacion Reforma 61-6 B2
Col Passo de las Lomas
CP013130
Mexico
T: +52 55 5258 9984

Amphenol Russia
Yaroslavskaja Street 8
129164 Moscow
Russia
T: +7 495 937 6341

Amphenol South Africa
30 Impala Road
2196 Chislehurst
Sandton
South Africa
T: +27 11 783 9517

Amphenol Turkey
Sun Plaza 15 Kat:
15 Maslak Hah. Bilim
Sok. No.5
Sisli/Istanbul, 34398
Turkey
T: +90 212 367 92 19

Amphenol LTD
MILITARY & AEROSPACE

For more information call +44 (0)1227 773200
Amphenol Ltd Thanet Way Whitstable Kent CT5 3JF | Email: info@amphenol.co.uk | www.amphenol.co.uk