

**Precision Wide  
Bandwidth Quad Analog Switches**

**Features**

- Single-Supply Operation (+2V to +6V)
- Rail-to-Rail Analog Signal Range
- Low On-Resistance (60hm typ @ 5V)  
Minimizes Distortion and Error Voltages
- $R_{ON}$  Matching Between Channels, 0.4 ohm typ
- On-Resistance Flatness, 2ohm typ
- Low Charge Injection.  $Q=4pC$  typ.  
Reduces Step errors, “clicking, popping” noise
- High Speed.  $t_{ON}$ , 10ns typ
- Very Low Crosstalk: -72dB @ 30 MHz
- Wide -3dB Bandwidth: >200 MHz
- High-Current Channel Capability: >100mA
- TTL/CMOS Logic Compatible
- Low Power Consumption (0.5 $\mu$ W typ)
- Pin-compatible with DG3XX, DG4XX, MAX39X

**Applications**

- Audio, Video Switching and Routing
- Battery-Powered Communication Systems
- Computer Peripherals
- Telecommunications
- Portable Instrumentation
- Mechanical Relay Replacement

**Description**

The PI5A391A/392A/393A are monolithic analog switches designed for low-voltage, single-supply operation. These high-precision devices are ideal for low-distortion audio, video, signal switching and routing applications.

The PI5A391A is a quad single-pole single-throw (SPST), normally closed (NC) switch. The PI5A392A has four normally open (NO) switches. The PI5A393A has two NC and two NO switches per package.

Each switch conducts current equally well in either direction when on. When off they block voltages up to the power-supply rails.

The PI5A391A/392A/393A are fully specified with +5V, and +3.3V supplies. With +5V, they guarantee <12-ohm on-resistance. On-resistance matching between channels is within 2-ohm. On-resistance flatness is less than 4ohm over the full signal range. The PI5A39X family guarantees fast switching speeds ( $t_{ON} < 20ns$ ).

These products are available in the 16-pin narrow-body SOIC, and QSOP packages for operation over the industrial (-40°C to +85 °C) temperature range.

**Functional Diagram, Pin Configuration and Truth Tables**

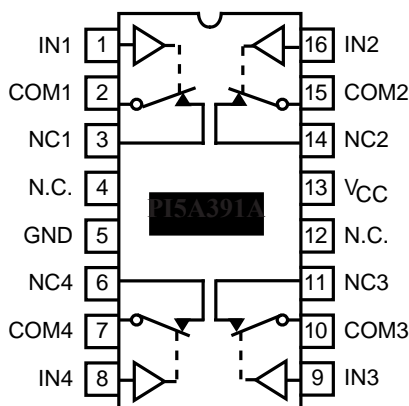

PI5A391A	
Logic	Switch
0	ON
1	OFF

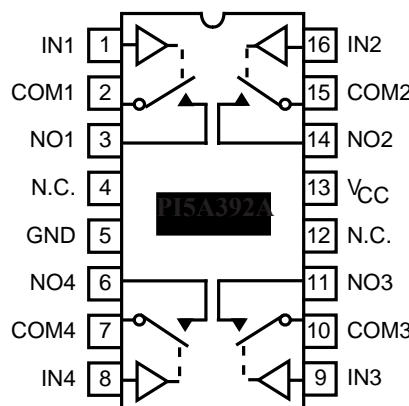

PI5A392A	
Logic	Switch
0	OFF
1	ON

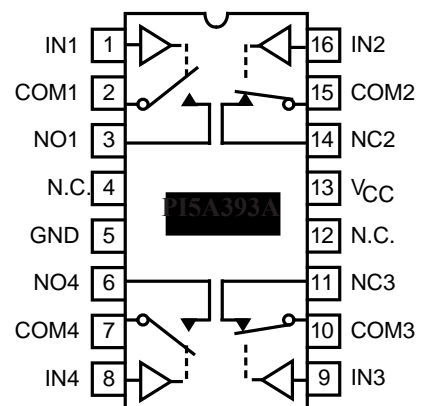

PI5A393A		
Logic	Switches 1,4	Switches 2,3
0	OFF	ON
1	ON	OFF

Switches are shown with logic "0" input.

### Maximum Ratings

(Above which the useful life may be impaired. For user guidelines, not tested.)

Storage Temperature .....	-65°C to +150°C
Ambient Temperature with Power Applied .....	-40°C to +85°C
Supply Voltage to Ground Potential .....	-0.5V to +7.0V
DC Input Voltage .....	-0.5V to V <sub>CC</sub> +0.5V
DC Output Current .....	120mA
Power Dissipation .....	0.5W

**Note:**

Stresses greater than those listed under MAXIMUM RATINGS may cause permanent damage to the device. This is a stress rating only and functional operation of the device at these or any other conditions above those indicated in the operational sections of this specification is not implied. Exposure to absolute maximum rating conditions for extended periods may affect reliability.

### Single 5.0V Supply

**DC Electrical Characteristics** (Over the Operating Range, T<sub>A</sub> = -40°C to +85°C, V<sub>CC</sub> = 5V ±10%, GND = 0V)

Parameters	Description	Test Conditions <sup>(1)</sup>	Min.	Typ <sup>(2)</sup>	Max.	Units
V <sub>ANALOG</sub>	Analog Signal Range		0	—	V <sub>CC</sub>	V
R <sub>ON</sub>	ON-Resistance	I <sub>NC</sub> or I <sub>NO</sub> = 10 mA to 30 mA	—	6	18	ohm
ΔR <sub>ON</sub>	Match Between Channels		—	0.4	2	ohm
R <sub>FLAT(ON)</sub>	R <sub>ON</sub> Flatness	I <sub>ON</sub> = 1 mA, V <sub>NO</sub> , V <sub>NC</sub> = 0V TO 5V	—	1	2	ohm
I <sub>NO(OFF)</sub> I <sub>NC(ON)</sub>	On/Off Leakage Current	V <sub>NO</sub> , V <sub>NC</sub> = 4.5V	-30	—	30	nA
I <sub>CC</sub>	Quiescent Supply Current	V <sub>CC</sub> = 5.5V, V <sub>IN</sub> = 0V OR V <sub>CC</sub>	—	—	100	nA
I <sub>O</sub>	Output Current	V <sub>NO</sub> , V <sub>NC</sub> OR V <sub>COM</sub> = 0V to 5V	100	—	—	mA
V <sub>IH</sub>	Input HIGH Voltage	Guaranteed Logic HIGH Level	2.0	—	—	V
V <sub>IL</sub>	Input LOW Voltage	Guaranteed Logic LOW Level	-0.5	—	0.8	V
I <sub>IH</sub>	Input HIGH Current	V <sub>CC</sub> = Max., V <sub>IN</sub> = V <sub>CC</sub>	—	—	±1	μA
I <sub>IL</sub>	Input LOW Current	V <sub>CC</sub> = Max., V <sub>IN</sub> = GND	—	—	±1	μA

**Notes:**

1. For Max. or Min. conditions, use appropriate value specified under Electrical Characteristics for applicable device type.
2. Guaranteed by design.

**Dynamic Electrical Characteristics** (Over the Operating Range,  $T_A = -40^{\circ}\text{C}$  to  $+85^{\circ}\text{C}$ ,  $V_{CC} = 5\text{V} \pm 10\%$ ,  $GND = 0\text{V}$ )

Parameters	Description	Test Conditions <sup>(1)</sup>	Min.	Typ <sup>(2)</sup>	Max.	Units
t <sub>ON</sub>	Turn-on Time	$V_{COM} = 3.0\text{V}$ , see Figure 1	—	10	20	ns
t <sub>OFF</sub>	Turn-off Time	$V_{COM} = 3.0\text{V}$ , see Figure 1	—	5	10	ns
X <sub>TALK</sub>	Crosstalk	$R_L = 100\text{ ohm}$ , $f = 30\text{ MHz}$ , see Figure 4	—	-72	—	dB
C <sub>(OFF)</sub>	NC or NO Capacitance	$f = 1\text{ kHz}$	—	13	—	pF
O <sub>IRR</sub>	Off Isolation	$R_L = 100\text{ ohm}$ , $f = 30\text{ MHz}$ , see Figure 5	—	-55	—	dB
BW	Bandwidth -3 dB	$R_L = 100\text{ ohm}$ , see Figure 3	—	200	—	MHz
D	Distortion $\Delta R_{ON}/R_L$	$R_L = 100\text{ ohm}$	—	2	—	%
Q	Charge Injection	$CL = 1\text{ nF}$ , $V_{Gen} = 0\text{V}$	—	3	5	pC

**Single 3.3V Supply**
**DC Electrical Characteristics<sup>(1)</sup>** (Over the Operating Range,  $T_A = -40^{\circ}\text{C}$  to  $+85^{\circ}\text{C}$ ,  $V_{CC} = 3.3\text{V} \pm 10\%$ ,  $GND = 0\text{V}$ )

Parameters	Description	Test Conditions <sup>(1)</sup>	Min.	Typ <sup>(2)</sup>	Max.	Units
V <sub>ANALOG</sub>	Analog Signal Range		0	—	$V_{CC}$	V
R <sub>ON</sub>	ON-Resistance	$I_{ON} = 10\text{ mA to }30\text{ mA}$	—	15	28	$\Omega$
$\Delta R_{ON}$	Match Between Channels		—	0.4	2	$\Omega$
R <sub>FLAT(ON)</sub>	R <sub>ON</sub> Flatness	$I_{ON} = 1\text{ mA}$ , $V_{NO}$ , $V_{NC} = 0\text{V to }5\text{V}$	—	1	2	$\Omega$
I <sub>NO(OFF)</sub> I <sub>NC(ON)</sub>	On/Off Leakage Current	$V_{NO}$ , $V_{NC} = 4.5\text{V}$	-30	—	30	nA
I <sub>CC</sub>	Quiescent Supply Current	$V_{CC} = 5.5\text{V}$ , $V_{IN} = 0\text{V or }V_{CC}$	—	—	100	nA
I <sub>O</sub>	Output Current	$V_{NO}$ , $V_{NC}$ or $V_{COM} = 0\text{V to }5\text{V}$	80	—	—	mA
V <sub>IH</sub>	Input HIGH Voltage	Guaranteed Logic HIGH Level	2.0	—	—	V
V <sub>IL</sub>	Input LOW Voltage	Guaranteed Logic LOW Level	-0.5	—	0.8	V
I <sub>IH</sub>	Input HIGH Current	$V_{CC} = \text{Max.}$ , $V_{IN} = V_{CC}$	—	—	$\pm 1$	$\mu\text{A}$
I <sub>IL</sub>	Input LOW Current	$V_{CC} = \text{Max.}$ , $V_{IN} = GND$	—	—	$\pm 1$	$\mu\text{A}$

**Dynamic Electrical Characteristics** (Over the Operating Range,  $T_A = -40^{\circ}\text{C}$  to  $+85^{\circ}\text{C}$ ,  $V_{CC} = 3.3\text{V} \pm 10\%$ ,  $GND = 0\text{V}$ )

Parameters	Description	Test Conditions <sup>(1)</sup>	Min.	Typ <sup>(2)</sup>	Max.	Units
t <sub>ON</sub>	Turn-on Time	$V_{COM} = 3.0\text{V}$ , see Figure 1	—	20	40	ns
t <sub>OFF</sub>	Turn-off Time	$V_{COM} = 3.0\text{V}$ , see Figure 1	—	10	20	ns
X <sub>TALK</sub>	Crosstalk	$R_L = 100\text{ ohm}$ , $f = 30\text{ MHz}$ , see Figure 4	—	-72	—	dB
C <sub>(OFF)</sub>	NC or NO Capacitance	$f = 1\text{ kHz}$	—	15	—	pF
O <sub>IRR</sub>	Off Isolation	$R_L = 100\text{ ohm}$ , $f = 30\text{ MHz}$ , see Figure 5	—	-55	—	dB
BW	Bandwidth -3 dB	$R_L = 100\text{ ohm}$ , see Figure 3	—	190	—	MHz
D	Distortion $\Delta R_{ON}/R_L$	$R_L = 100\text{ ohm}$	—	2	—	%
Q	Charge Injection	$CL = 1\text{ nF}$ , $V_{Gen} = 0\text{V}$	—	3	10	pC

**Notes:**

1. For conditions shown as Max or Min, use appropriate value specified under Electrical Characteristics for applicable device type.
2. Guaranteed by design.
3.  $\Delta R_{ON} = \Delta R_{ON\text{ max}} - R_{ON\text{ min}}$ .
4. Flatness is defined as the difference between the maximum and minimum value of on-resistance as measured over the specified analog signal range.

## Applications

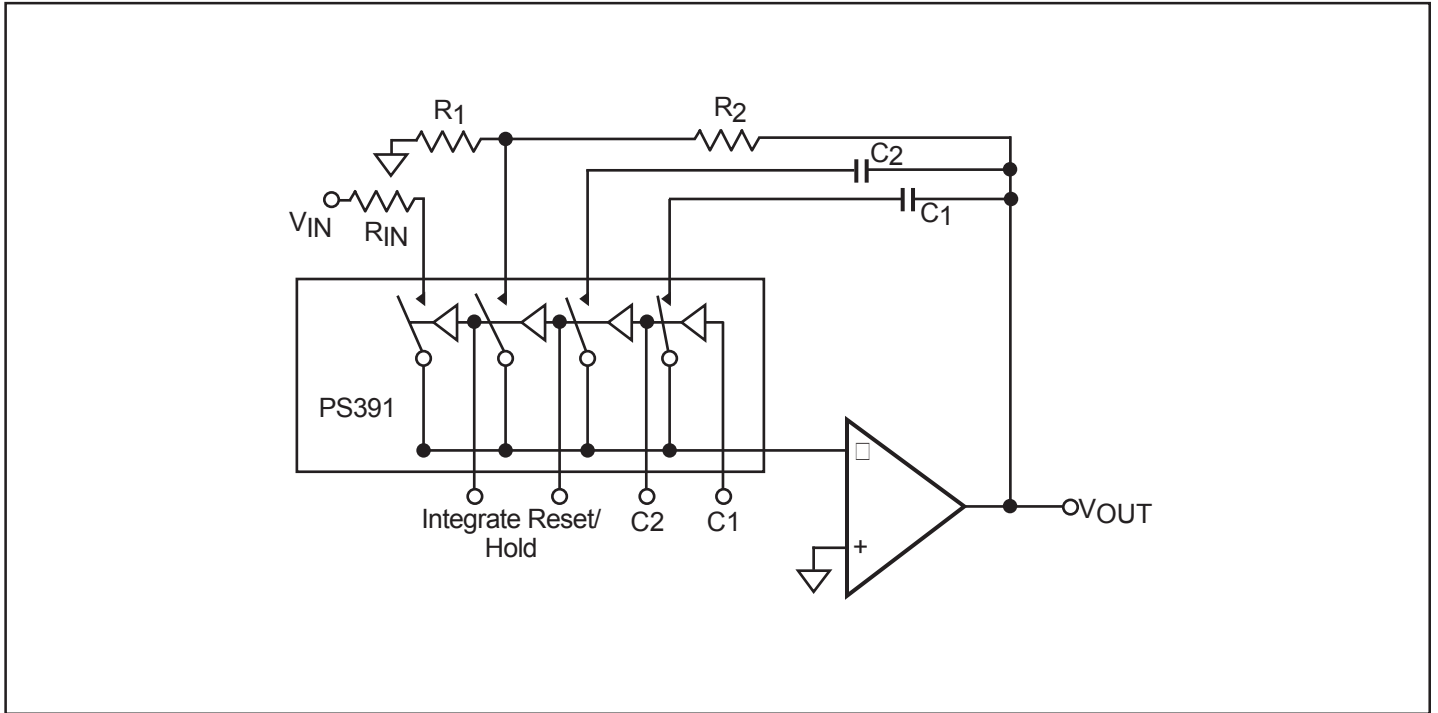

**Figure 1. Programmable Integrator and Sample/Hold**

The 5A39X can be used to insert various capacitors (C1, C2) and set proper RC times for integration. Resistors  $R_1$  and  $R_2$  set initial gain. The  $R_{IN}$  resistor X C1 or C2 sets the RC time. The reset switch discharges the hold capacitor through  $R_{IN}$ .

Test Circuits

Figure 2. Switching Time

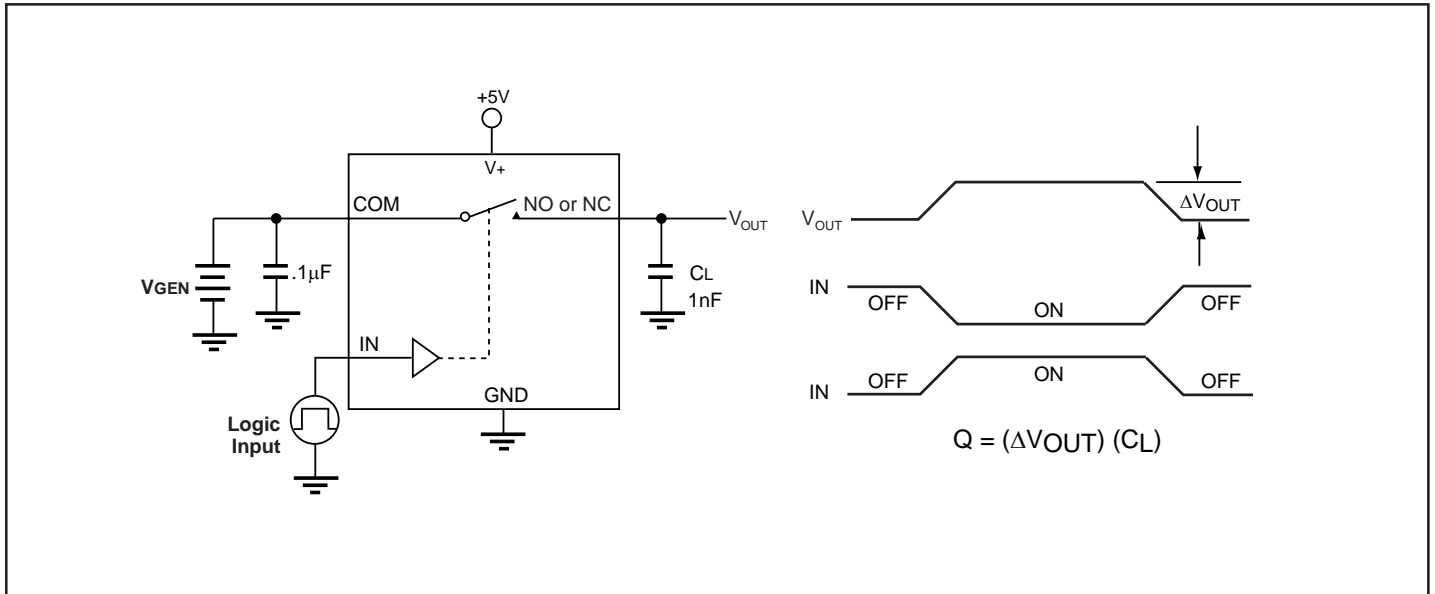
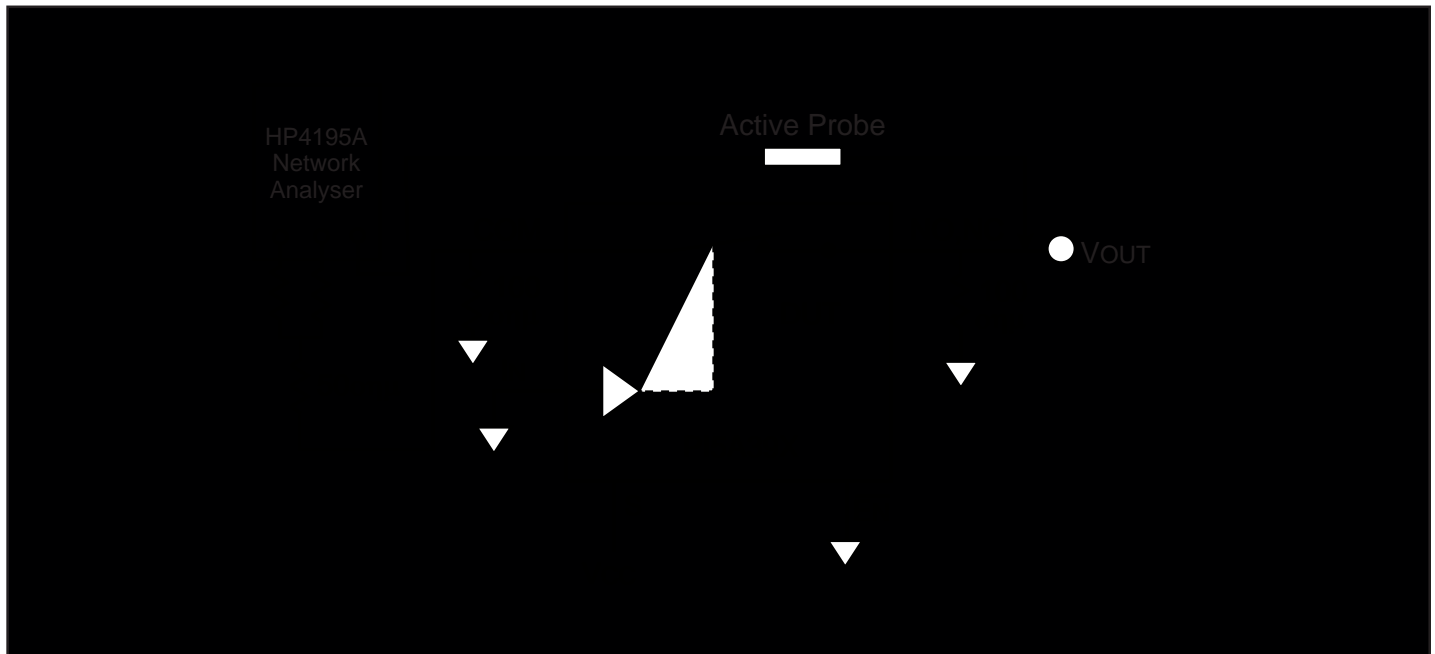

Figure 3. Bandwidth



Typical Operating Characteristics

Figure 4. Crosstalk

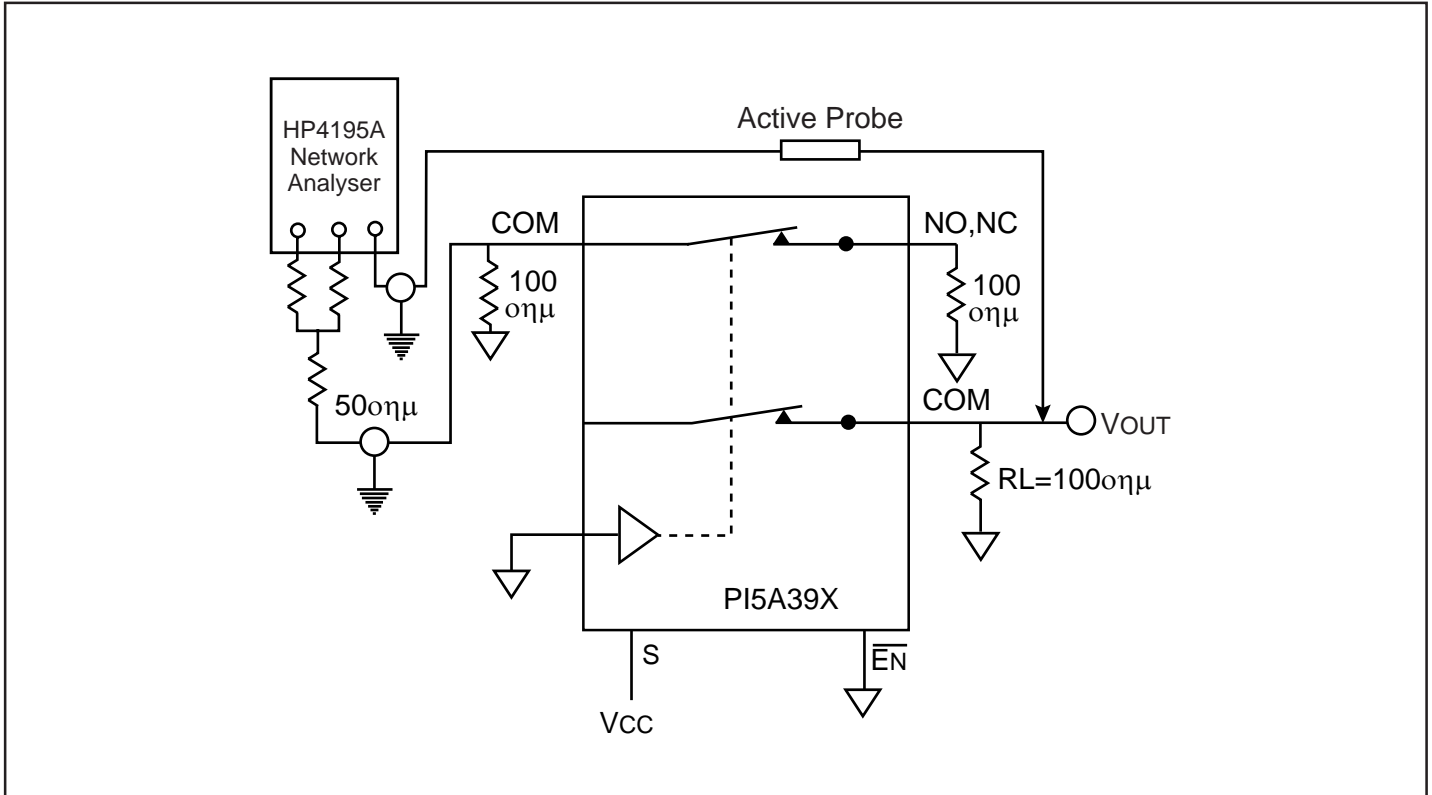
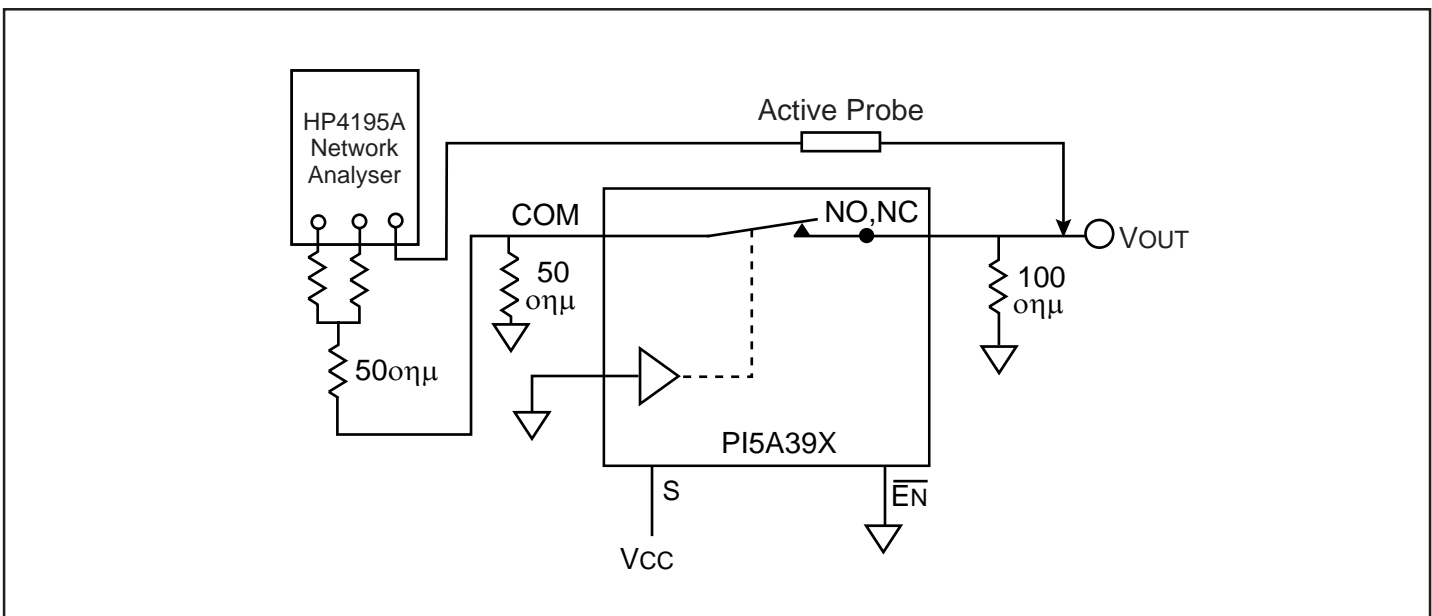
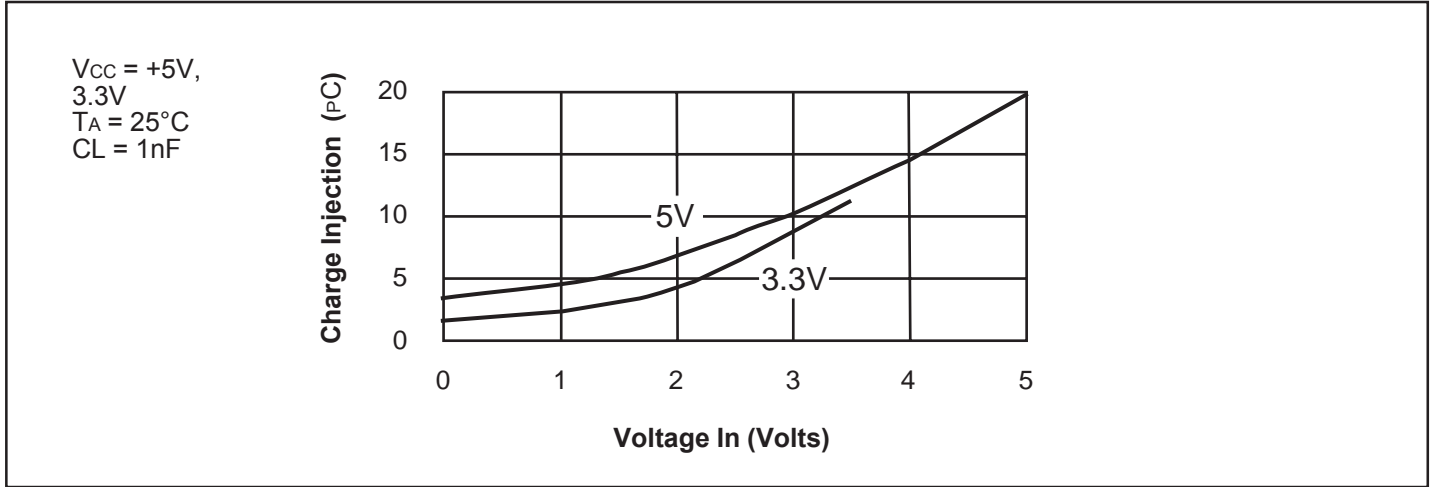

Figure 5. Off Isolation



**Figure 6. Charge Injection vs Voltage In**



**Figure 7. On-Resistance vs Input Voltage**

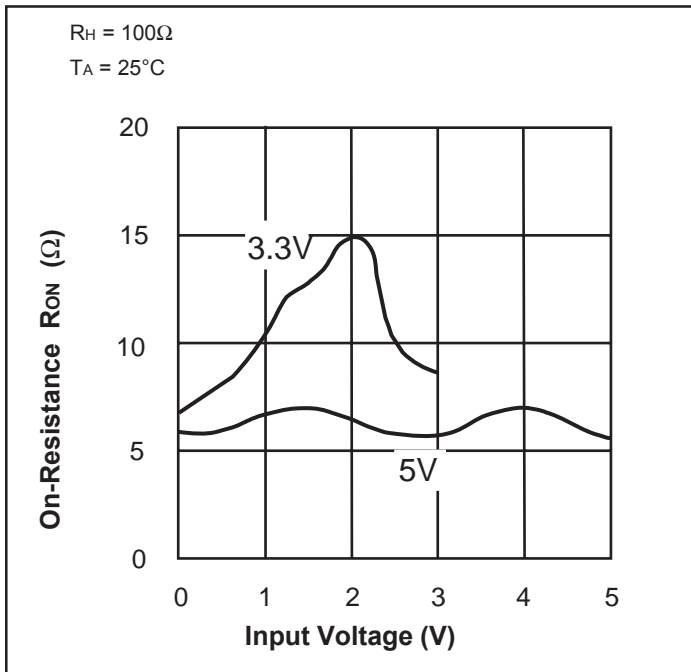

**Figure 8. Insertion Loss vs Frequency**

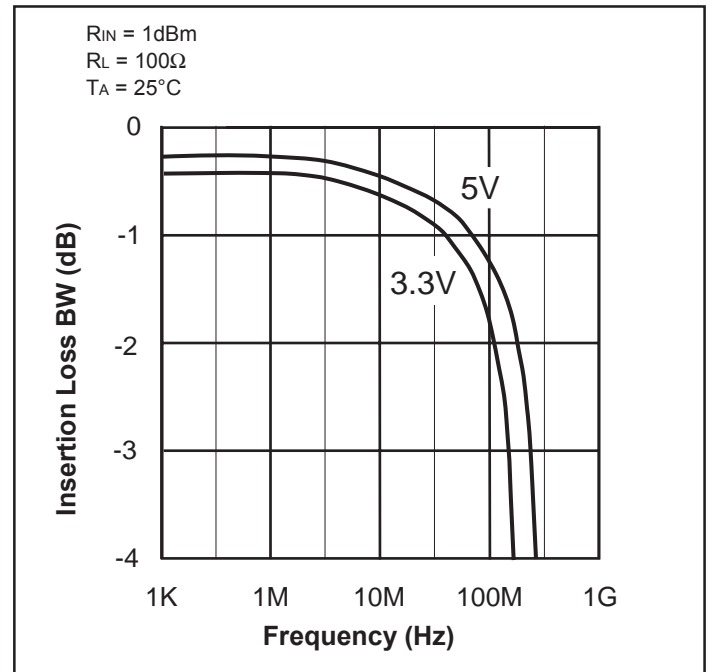

Figure 9. Off Isolation vs Frequency

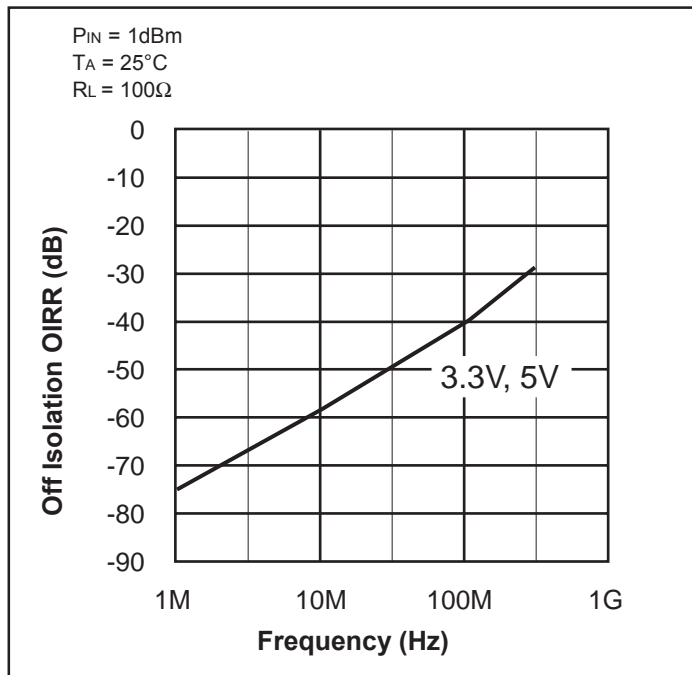
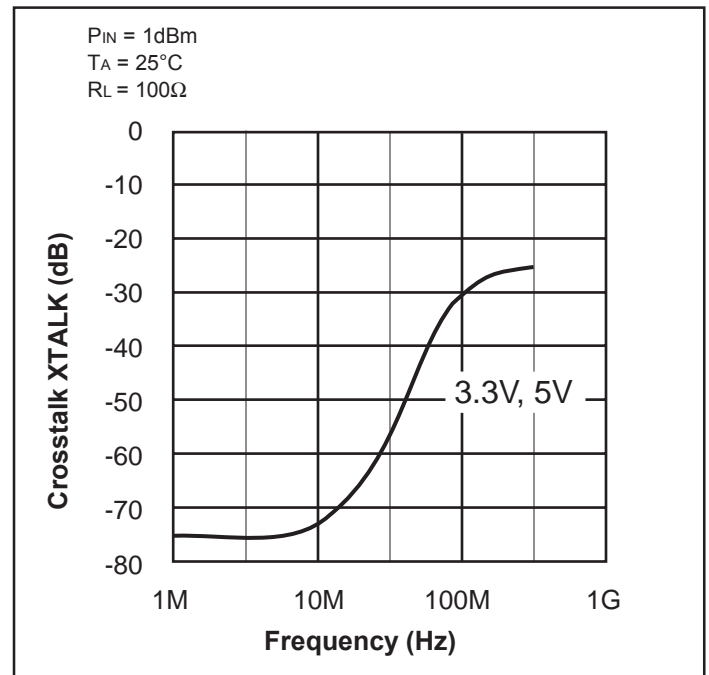
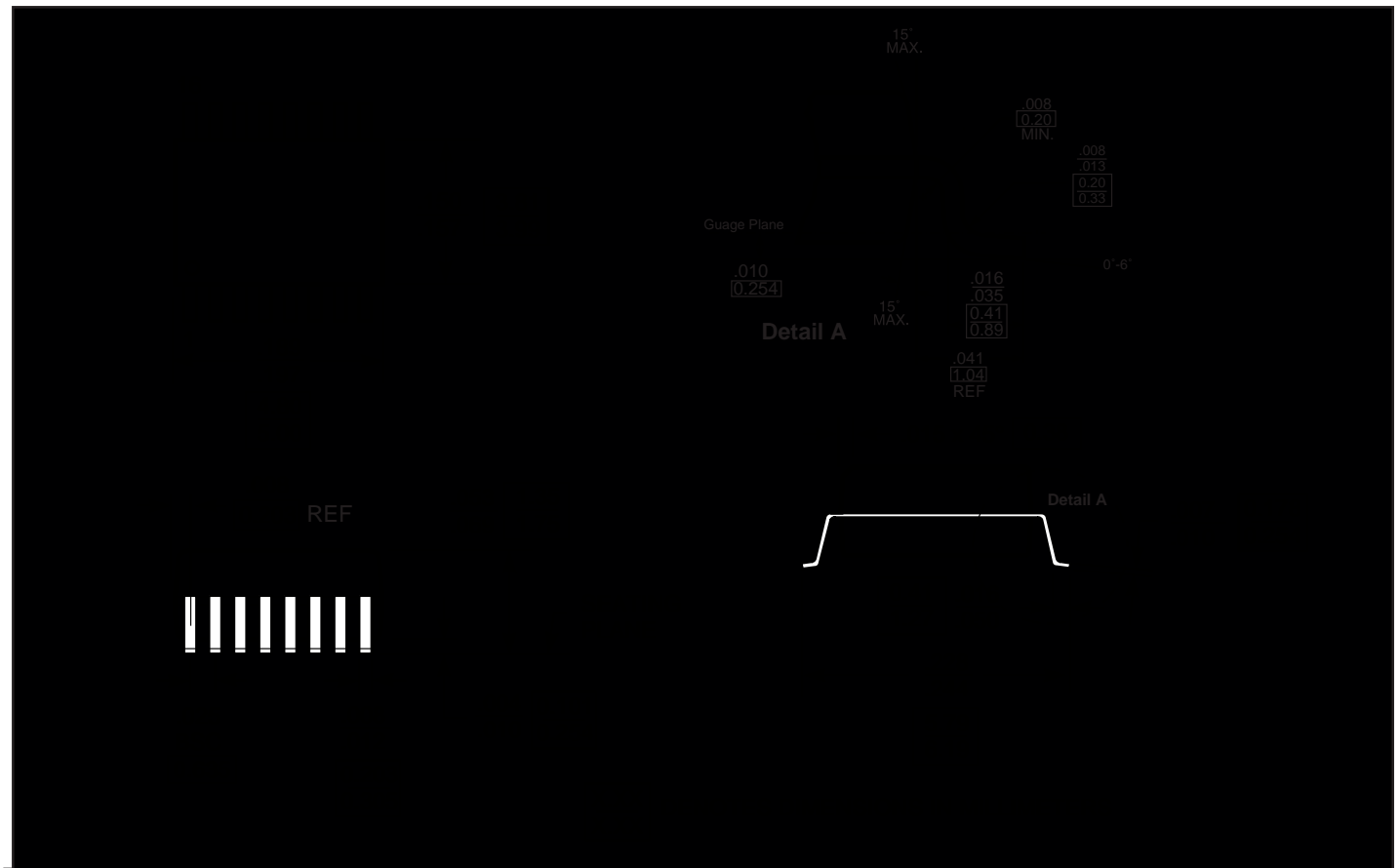

Figure 10. Crosstalk vs Frequency



Packaging Mechanical: 16-Pin, QSOP





**Packaging Mechanical: 16-Pin, SOIC**

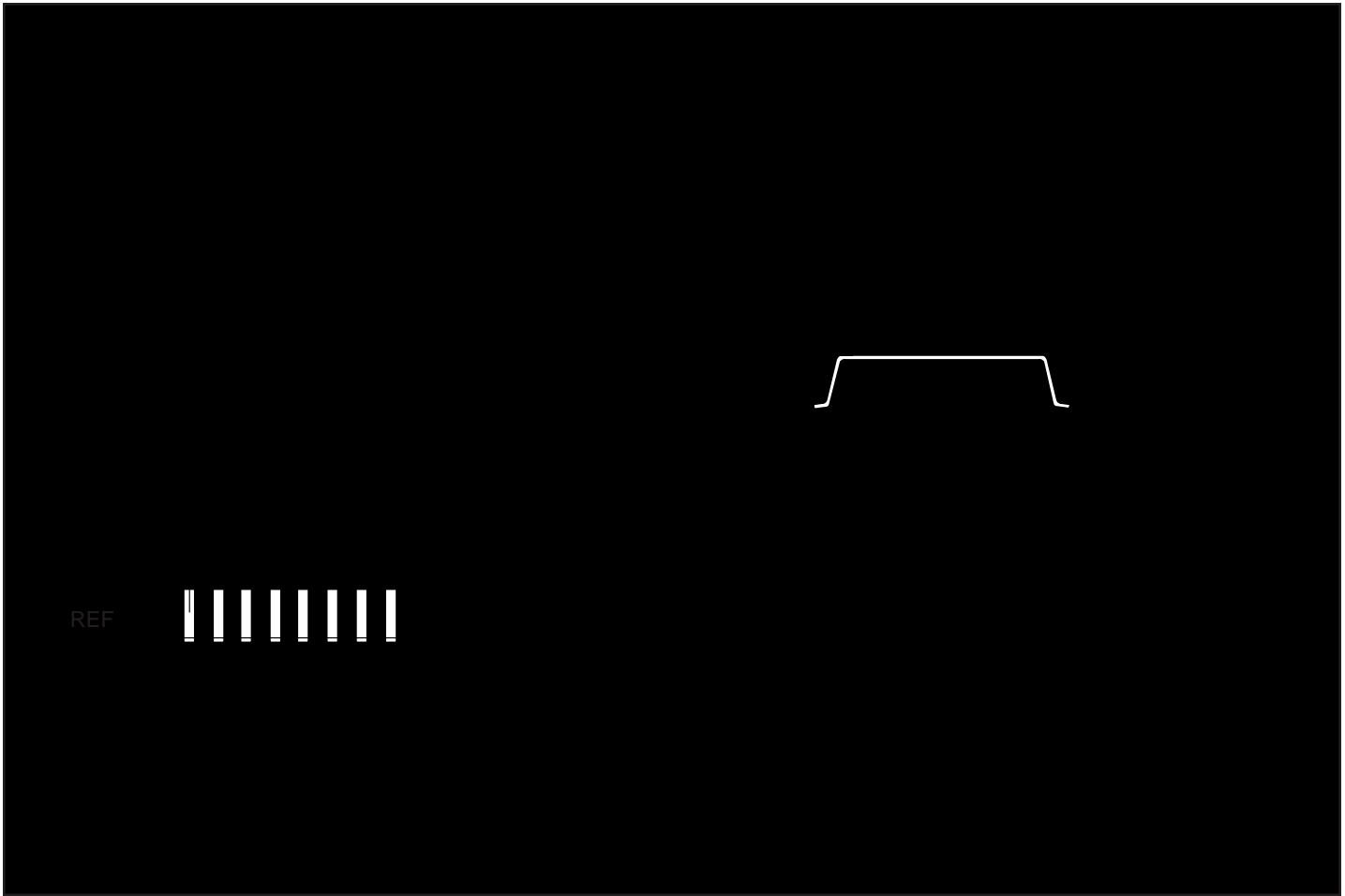

**Ordering Information**

Part Number	Package	Package Code	Temperature
PI5A391AQ	16-Pin, QSOP	Q16	-40°C to +85°C
PI5A391AW	16-Pin, SOIC	W16	
PI5A392AQ	16-Pin, QSOP	Q16	
PI5A392AW	16-Pin, SOIC	W16	
PI5A393AQ	16-Pin, QSOP	Q16	
PI5A393AW	16-Pin, SOIC	W16	