

11.99
[.472]

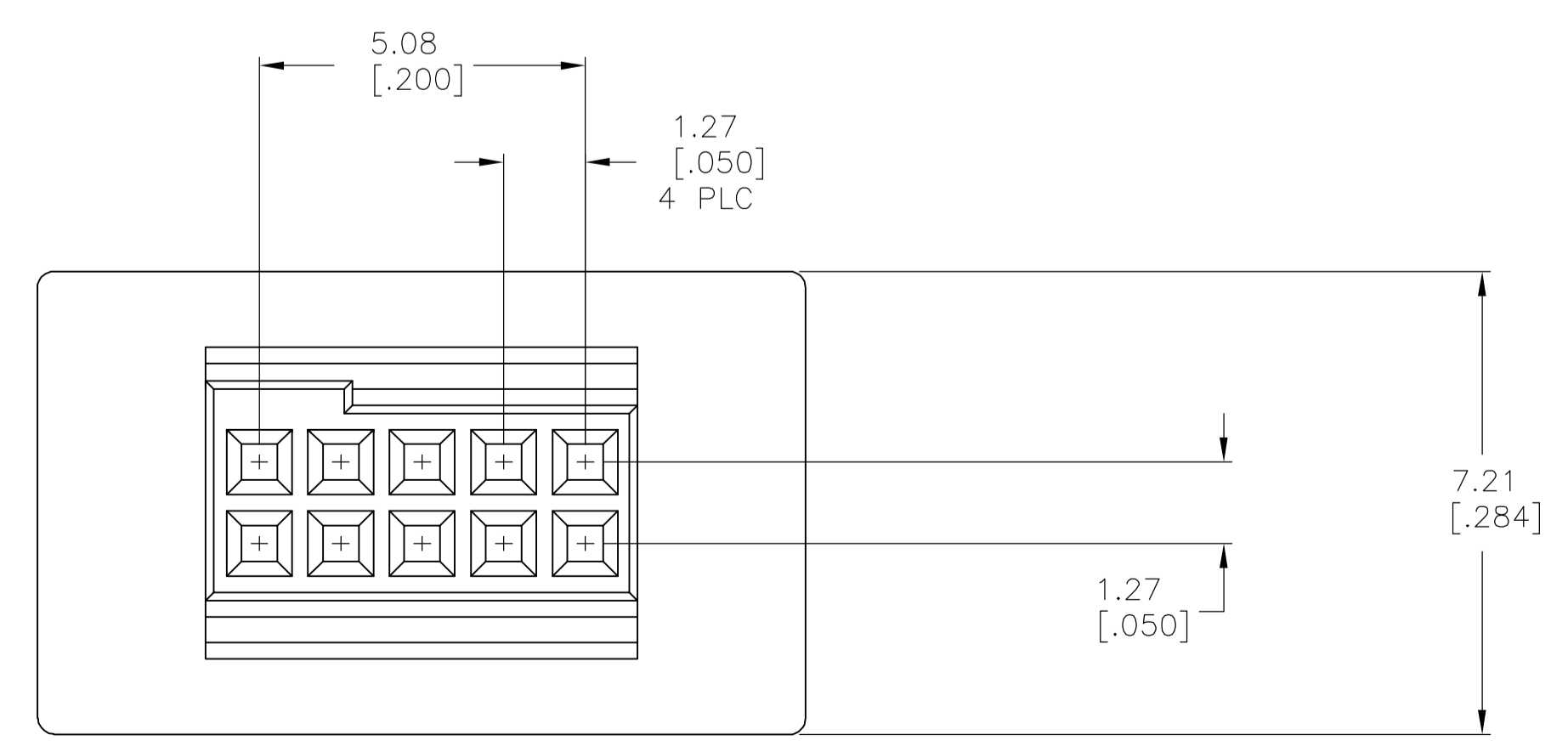

- 1 MATERIAL:
 RECEPTACLE CONTACTS- PHOSPHOR BRONZE
 RECEPTACLE HOUSING: LCP; BLACK
 TERMINATING COVERS: NONE, 5
- 2 PLATING:
 RECEPTACLE CONTACTS- 0.00076 [.000030] MINIMUM GOLD PLATE IN CONTACT AREA,
 0.00127 [.000050] MINIMUM BRIGHT TIN-LEAD PLATE IN TERMINATION AREA,
 ALL OVER 0.00127 [.000050] MINIMUM NICKEL.
- 3. RECOMMENDED WIRE:
 28 AWG- 0.91 [.036] MAX O.D. PVC OR POLYETHYLENE INSULATION.
- 4. SHORT-LONG CONTACT SEQUENCE MUST ALTERNATE BUT MAY BEGIN WITH EITHER
 A SHORT OR LONG CONTACT.
- 5 THIS CONNECTOR ASSEMBLY WAS ORIGINALLY DESIGNED TO BE USED WITH AN APPROPRIATE TERMINATING
 COVER, WHICH WAS DESIGNED TO PROPERLY POSITION THE CABLE ON THE INSULATION DISPLACEMENT
 CONTACTS PRIOR TO AND DURING TERMINATION. BECAUSE CUSTOMER DOES NOT INTEND TO USE SUCH COVER,
 CUSTOMER MUST PROVIDE ADEQUATE ALTERNATIVE MEANS TO PROPERLY POSITION THE CABLE PRIOR TO AND
 DURING TERMINATION.
- 6 PLATING: RECEPTACLE CONTACTS-0.00076 (.000030) MINIMUM GOLD PLATE IN CONTACT AREA,
 0.00127 (.000050) MINIMUM TIN PLATE IN TERMINATION AREA, ALL OVER 0.00127 (.000050)
 MINIMUM NICKEL
- 7 ROHS 2002/95/EC COMPLIANT.

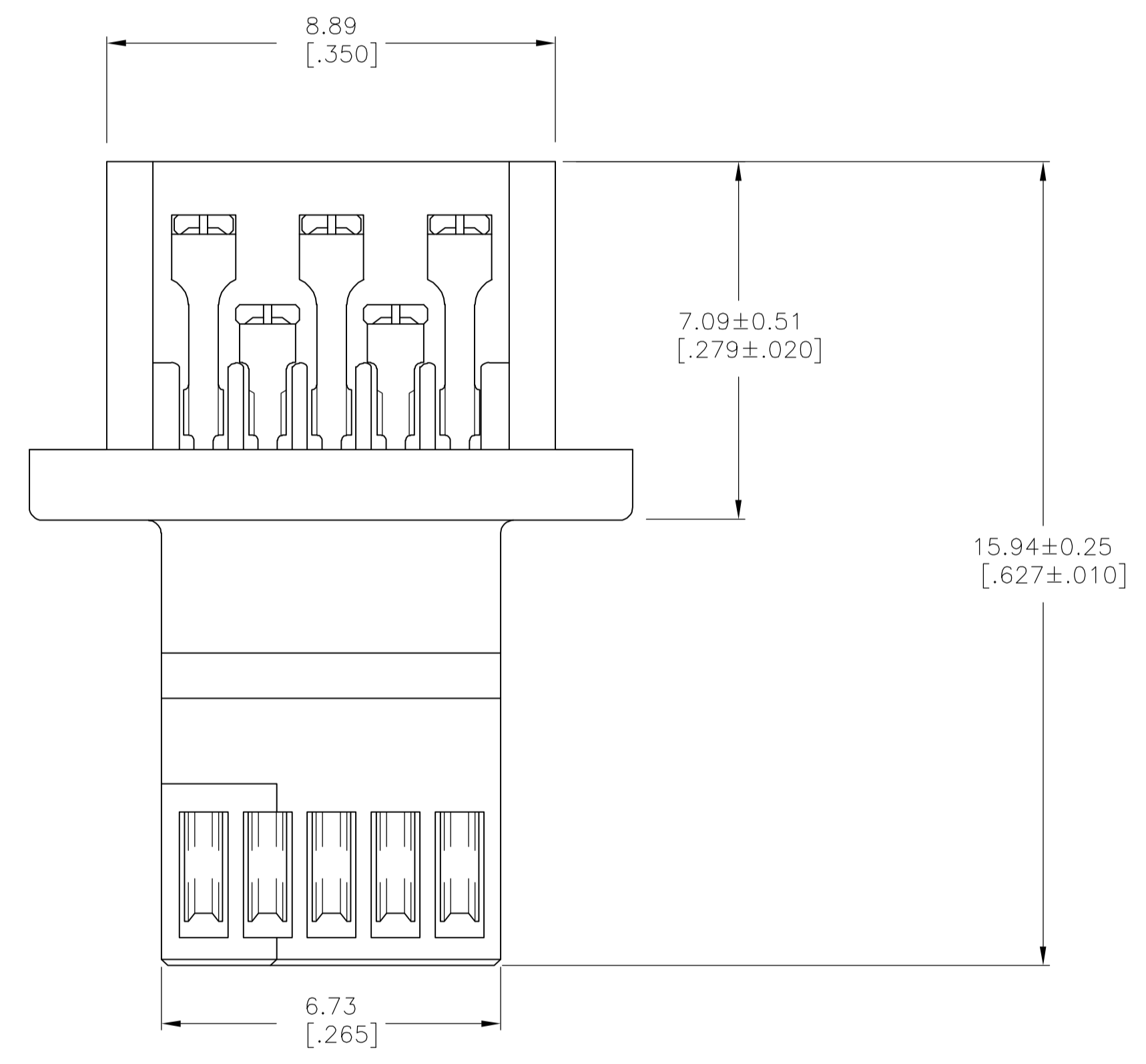
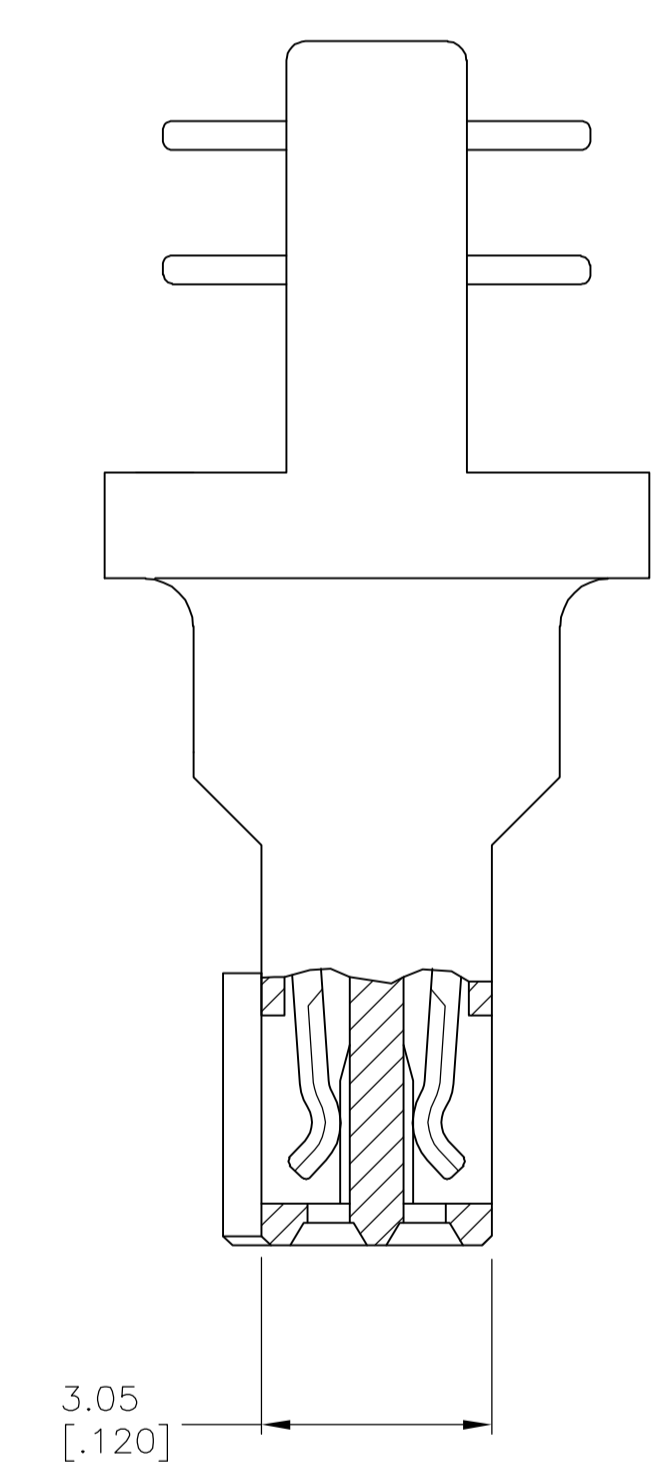

5-111672-1
 111672-1
 PART NUMBER

THIS DRAWING IS A CONTROLLED DOCUMENT.		DWN C. REIFSNYDER 17 JAN 97	Tyco Electronics Corporation Harrisburg, Pa 17105-3608	
DIMENSIONS: mm [INCHES]		CHK J.D. STINE 20 JAN 97	NAME CABLE CONNECTOR ASSY, 10 POSN, UNLATCHED, 50/50 GRID, AMPMODU	
TOLERANCES UNLESS OTHERWISE SPECIFIED:		APP'D J.D. STINE 20 JAN 97	PRODUCT SPEC 108-1443	
0 PLC ± -		APPLICATION SPEC 114-7010		
1 PLC ± -		SIZE A1		
2 PLC ± 0.15(.005)		CAGE CODE 00779		
3 PLC ± -		DRAWING NO 111672		
4 PLC ± -		RESTRICTED TO -		
ANGLES ± -		WEIGHT -		
FINISH		CUSTOMER DRAWING		
1		SCALE 10:1 SHEET 1 OF 1 REV C		
2		6		