

Dimmable High Voltage LED *Archimedes Series* Direct AC Driver

Features

- Integrated Bridge Rectifier and MOSFET Driver
- Wide AC input range up to 310 Vac 50/60Hz
- 50mA DC output current
- Ultra simple circuit solution. Requires Only One R passive component
- Thermal Turndown Protections
- Voltage Shutdown Protections
- Thermal Enhanced SOP-8 and Heat Sink PAD package
- TRIAC Dimmable (Leading/Trailing Edge)
- Programmable LED Current with an external sense resistor

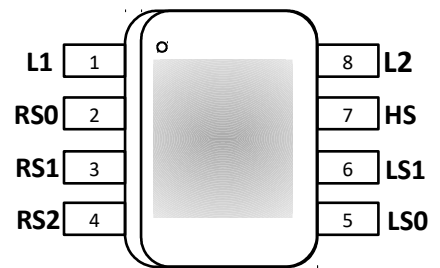

Applications

- LED Driver
- Current Source limiter
- General Illumination
- Commercial and Industrial Lighting

Description

The **LS9100** is a High Voltage full-bridge rectifier combined with a current limiter source circuit and protection circuit. Its rugged design is optimized for driving LED banks directly from the main utility line eliminating external components by merging them into a monolithic package, drastically reducing the board space and cost. The thermal turndown located in the center of the IC protects itself from operating in atypical conditions. The voltage shutdown protection circuit safeguards the IC and the system's LEDs from voltage surges that can overstress the system.

Ordering Information

Part Number	Description
LS9100X-S	
LS9100X-STR	SOP-8: Tape and Reel (1000/Reel)

PIN Configuration

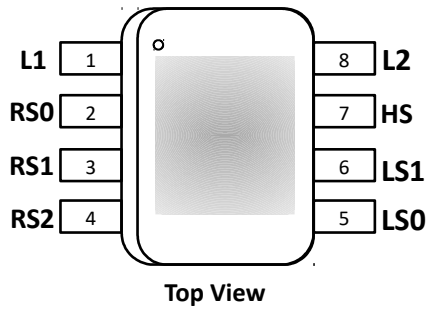

PIN #	Name	Description
1	L1	Input 1 AC
2	RS0	Current sense resistor input 0
3	RS1	Current sense resistor input 1
4	RS2	Current sense resistor input 2
5	LS0	Low Side input 0
6	LS1	Low Side input 1
7	HS	High side output
8	L2	Input 2 AC
PAD	xPAD	Current sense resistor input 0

Block Diagram

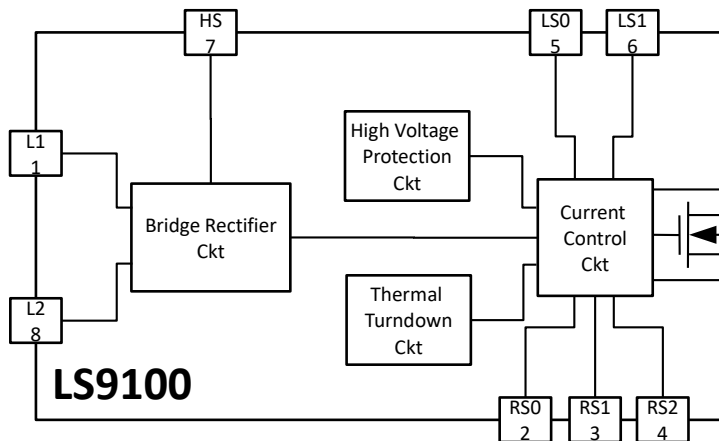

Maximum Rating And Electrical Characteristics

Rating at 25°C ambient temperature unless otherwise specified (Note).

Parameter	Symbol	Min	Typ	Max	Unit
Repetitive peak reverse voltage (Input L1-L2)	Vrrm			500	V
DC Blocking voltage (Input L1-L2)	Vdc			500	V
RMS Voltage (Input L1-L2)	Vrms			310	V
Instantaneous forward voltage (L1-2/HV)	Vf		0.75		V
Average forward current (L1-2/HV)	I _{av}			50	mA
Peak Forward surge current (Note 2)	I _{fsm}			80	mA
DC reverse current @TA=25°C @TA=100°C	I _r			.5 1.00	uA
Low Side peak voltage (Input LS0-1)	V _{ls}		100	350	V
Low Side Voltage Shutdown Protection (Input LS0-1)	V _{shdw}	115	130	145	V
Total Low Side Current (Input LS0-1)			50	140	mA
Package Power Dissipation (Note 3)	PD _{pkd}			2500	mW
Typical Thermal resistance (Note 3)	R _{θja}			45	°C/W
Typical Junction capacitance (PIN 1,8)	C _j		45		pF
Operating Junction Temperature	T _j	-40		+125	°C
Current Thermal turndown	I _{tdw}		-0.32		%A/°C
Storage temperature	T _{strg}	-55		+125	°C
Junction Temperature	T _{jmax}			+150	°C
Lead Temperature (10 second soldering)	T _{sld}			+300	°C

Notes:

1. Stresses above these ratings may cause permanent damage. Exposure to absolute maximum conditions for extended periods may degrade device reliability.
2. 1msec half sine wave superimposed on rated load
3. Power dissipated from junction to lead PCB mounted on suggested PAD Layout. Derate 20mW/°C when the ambient temperature is above 25 °C. Special care of the thermal dissipation in the PCB design must be taken.
4. ESD protection. HBM : 1kV at all Pins.

Electrostatic Discharge Sensitivity



This integrated circuit can be damaged by ESD. LSI/CSI recommends that all integrated circuits be handled with appropriate precautions. Failure to observe proper handling and installation procedures can cause damage. ESD damage can range from subtle performance degradation to complete device failure. Precision integrated circuits may be more susceptible to damage because very small parametric changes could cause the device not to meet its published specifications.

Typical Application

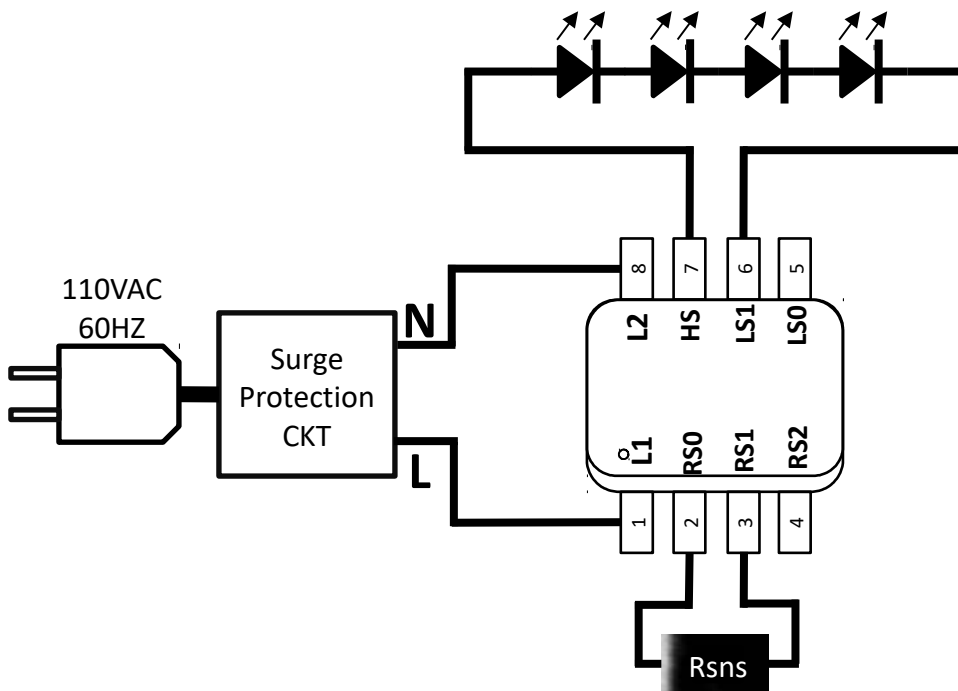

DANGER!: THE READER IS WARNED THAT CAUTION MUST BE USED IN THE CONSTRUCTION, TESTING AND USE OF THIS CIRCUIT. LETHAL HIGH VOLTAGE POTENTIALS ARE PRESENT IN THIS CIRCUIT. EXTREME CAUTION MUST BE USED IN WORKING WITH, AND MAKING CONNECTIONS TO, THIS CIRCUIT. USE CAUTION.

Typical Characteristics

At $T_{amb} = +25$, unless otherwise noted.

Output Current (I_{csns}) vs. External Resistor (R_{csns})

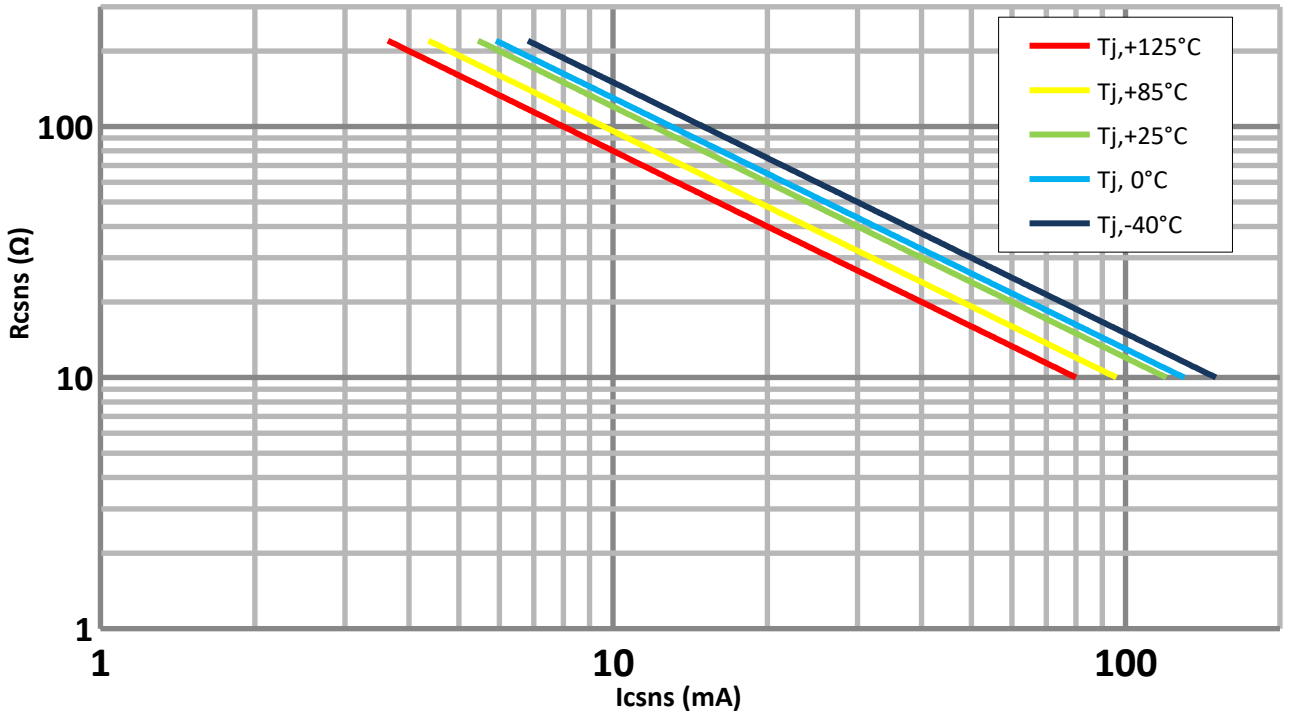

Total Power Dissipation (mW) vs. Ambient Temperature (T_a)

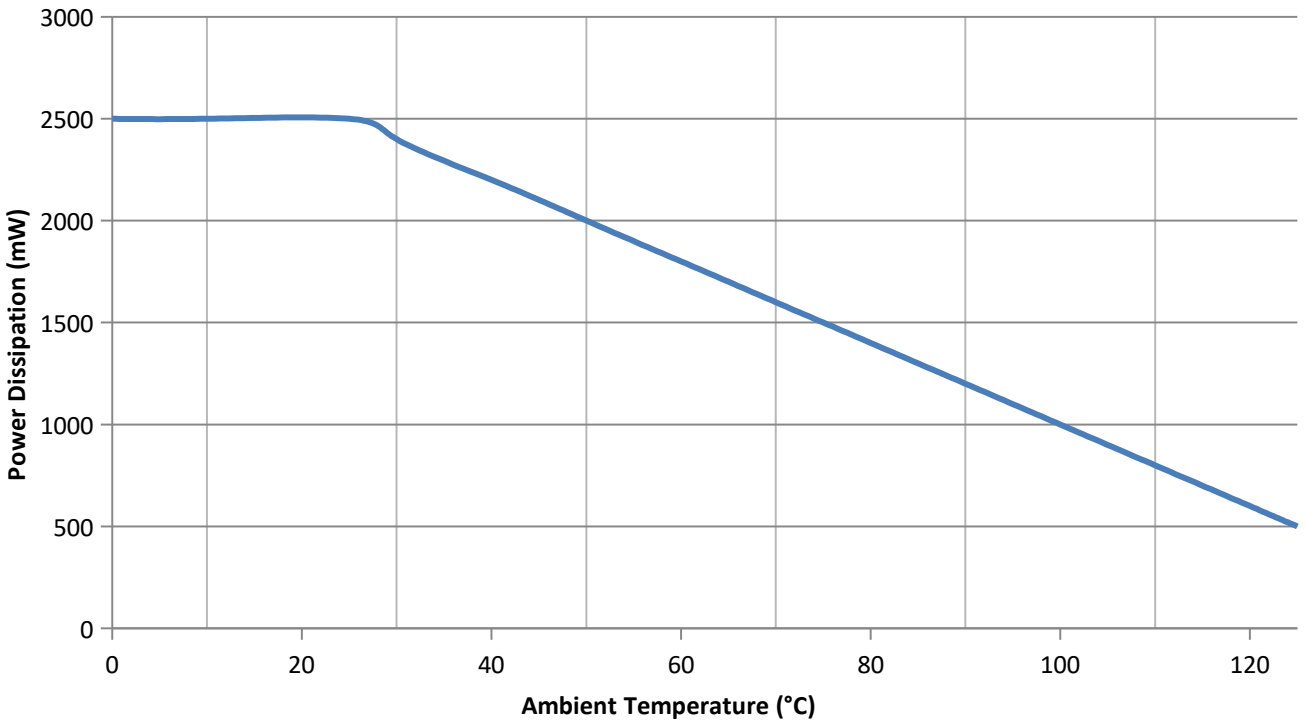

Package Information 8-Lead SOP Exposed Pad Plastic Package

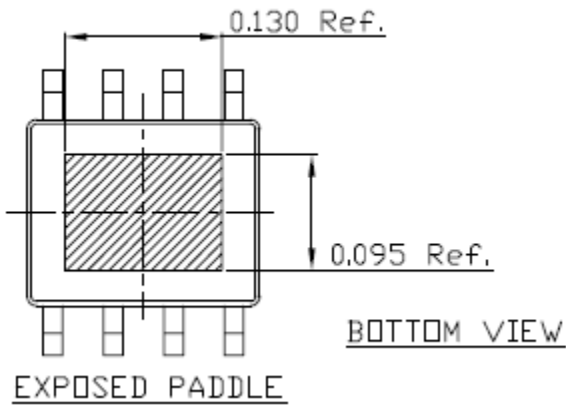
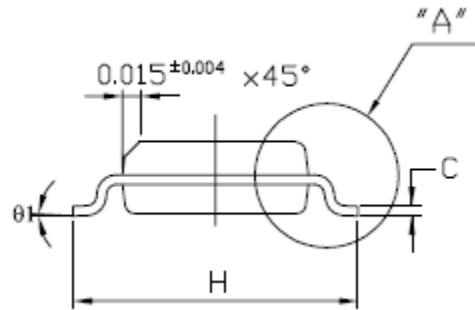
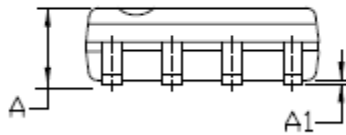
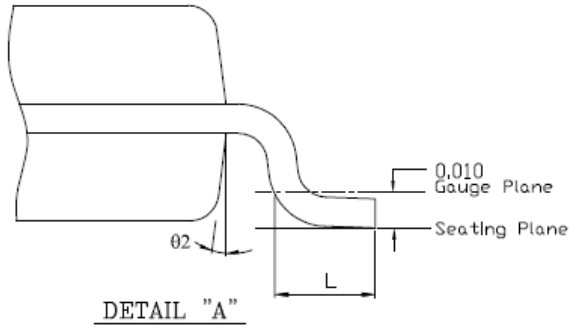
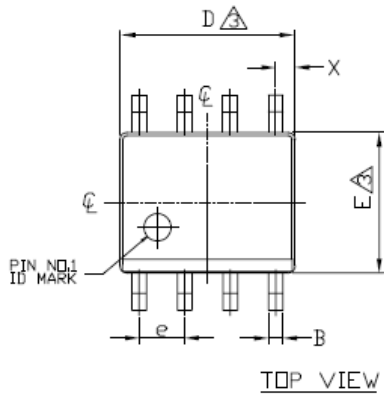

SYMBOL	8 SOIC	
	MIN	MAX
A	0.054	0.068
A1	0.001	0.004
B	0.014	0.019
D	0.189	0.196
E	0.150	0.157
H	0.229	0.244
e	0.050 BSC	
C	0.0075	0.0098
L	0.020	0.040
X	0.0215 REF	
θ1	0°	8°
θ2	7° BSC	

Notes:

- A. All linear dimension are in inches.
- B. The thermal pad is design to be solder on the PCB.
- C. This drawing is subject to change without notice.

Package Mounting

The figure below provides the minimum recommended PCB layout for the LS9100 device. For lowest overall thermal resistance, it is best to solder the heat sink Pad directly to the circuit board. Adding more area to the heat sink improves heat dissipation.

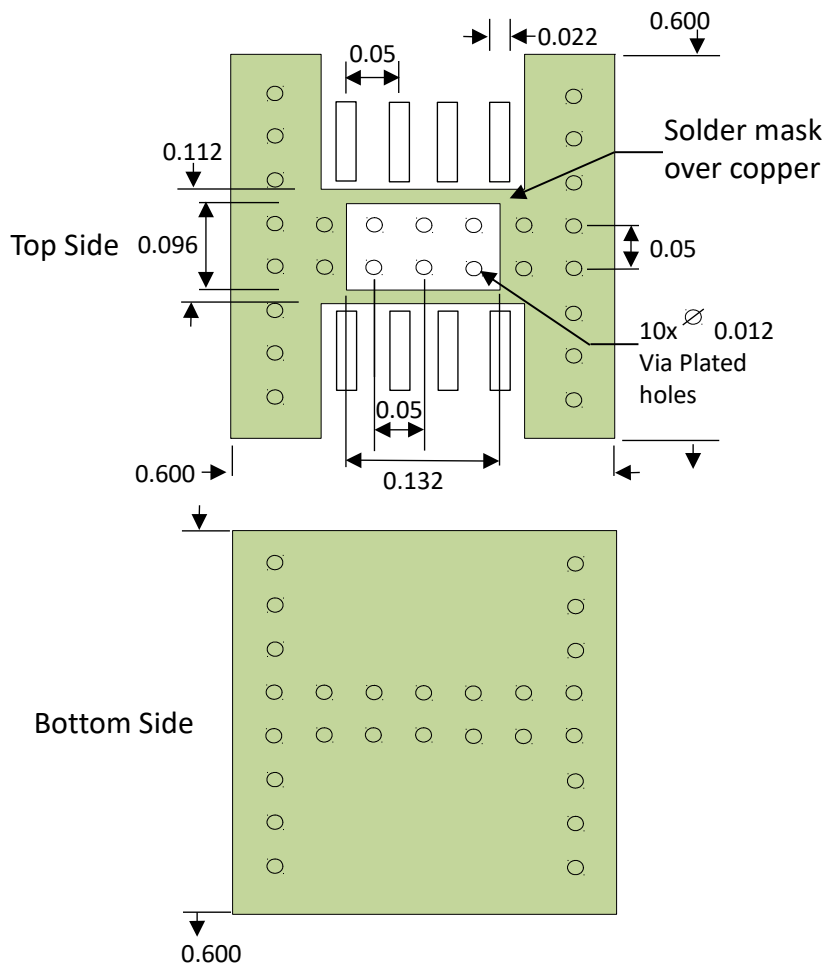

Notes:

- All linear dimension are in inches (not to scale).
- This drawing is subject to change without notice.
- This package mounting is a guideline example and does not cover all applications.
- Conformal Coating material must be applied to act as protection against moisture and harsh environments.



IMPORTANT NOTICE

The information included herein is believed to be accurate and reliable. However, LSI Computer Systems, Inc. assumes no responsibilities for inaccuracies, nor for any infringements of patent rights of others which may result from its use. LSI Computer Systems reserves the right to change circuitry and specifications at any time without notification to the customer. LSI Computer Systems assumes no liability for applications assistance or the design of Buyers' products. Buyers are the only responsible for their products and applications using LSI Computer Systems components. To minimize the risks associated with Buyers' products and applications, Buyers should provide adequate design and operating safeguards.