

**STRAIGHT JACK RECEPTACLE FOR PCB**

**R113.423.000**

**SMT TYPE - EDGE CARD**

Series : MCX

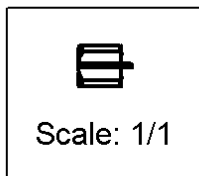
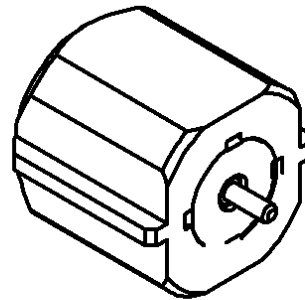
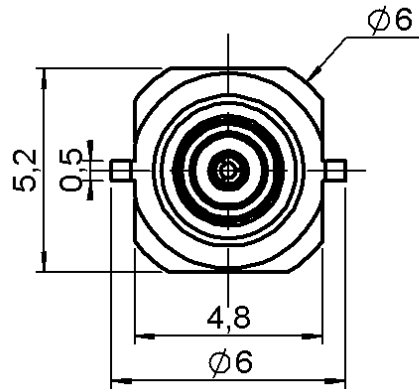
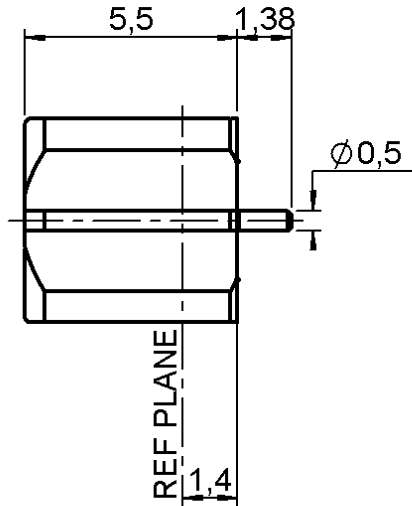

All dimensions are in mm.

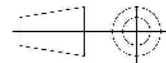

COMPONENTS	MATERIALS	PLATINGS (µm)
BODY	BRASS	GOLD 0.2 OVER NICKEL 2
CENTER CONTACT	BERYLLIUM COPPER	GOLD 1.3 OVER NICKEL 2
OUTER CONTACT	-	-
INSULATOR	PTFE	-
GASKET	-	-
OTHERS PARTS	-	-
-	-	-
-	-	-

Issue : 0424 D

In the effort to improve our products, we reserve the right to make changes judged to be necessary.



**STRAIGHT JACK RECEPTACLE FOR PCB**

**R113.423.000**

**SMT TYPE - EDGE CARD**

Series : MCX

**PACKAGING**

**SPECIFICATION**

Standard	Unit	Other
<b>100</b>	<b>'W' option</b>	<b>Contact us</b>

**ELECTRICAL CHARACTERISTICS**

**ENVIRONMENTAL**

Impedance		<b>50</b> Ω
Frequency		<b>0-6</b> GHz
VSWR	<b>1.05</b> * +	<b>0.015</b> x F(GHz) Maxi
Insertion loss		<b>0.03</b> * √F(GHz) dB Maxi
RF leakage	- (	<b>NA</b> - F(GHz)) dB Maxi
Voltage rating		<b>335</b> Veff Maxi
Dielectric withstanding voltage		<b>1000</b> Veff mini
Insulation resistance		<b>1000</b> MΩ mini

Operating temperature	<b>-55/+155</b> ° C
Hermetic seal	<b>NA</b> Atm.cm3/s
Panel leakage	<b>NA</b>

**OTHERS CHARACTERISTICS**

Assembly instruction

Others :

\* Coaxial Tansmission Line Only

**MECHANICAL CHARACTERISTICS**

Center contact retention		
Axial force – Mating end	<b>10</b>	N mini
Axial force – Opposite end	<b>10</b>	N mini
Torque	<b>NA</b>	N.cm mini
Recommended torque		
Mating	<b>NA</b>	N.cm
Panel nut	<b>NA</b>	N.cm
Mating life	<b>500</b>	Cycles mini
Weight	<b>0.850</b>	g

Issue : 0424 D

In the effort to improve our products, we reserve the right to make changes judged to be necessary.



**STRAIGHT JACK RECEPTACLE FOR PCB**

**R113.423.000**

**SMT TYPE - EDGE CARD**

Series : MCX

**SOLDER PROCEDURE**

1. Deposit solder paste 'Sn Ag4 Cu0.5' on mounting zone by screen printing application. We recommend a low residue flux.  
We advise a thickness of 150 micromm ( 5.850 microinch ). Verify that the edges of the zone are clean.
2. Placement of the receptacle on the mounting zone with an automatic machine of 'pick and place' type.
3. Soldering by infra-red reflow.
4. Cleaning of printed circuit boards.
5. Checking of solder joints and position of the component by visual inspection.

**TEMPERATURE PROFILE**

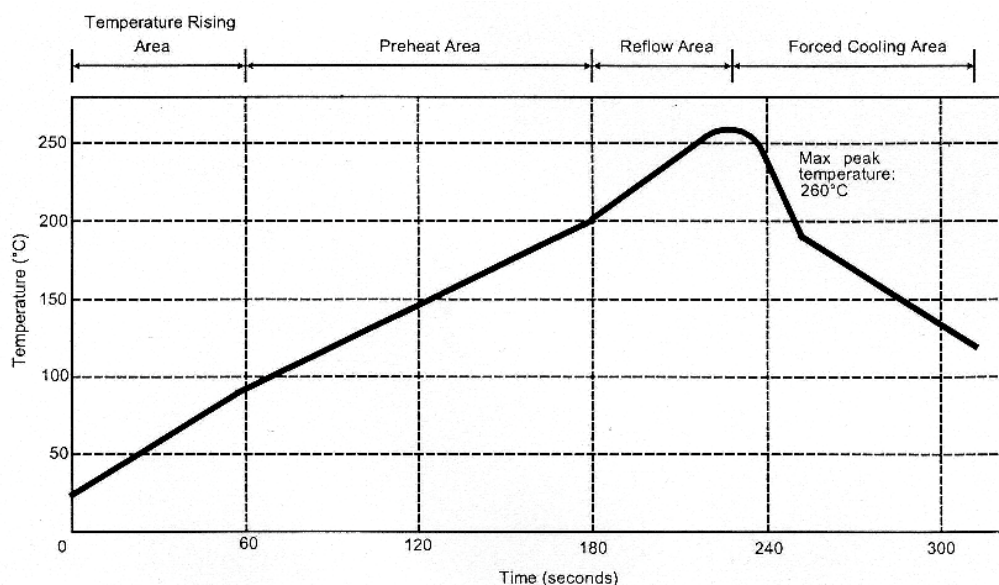

Parameter	Value	Unit
Temperature rising Area	1 - 4	°C/sec
Max Peak Temperature	260	°C
Max dwell time @260°C	10	sec
Min dwell time @235°C	20	sec
Max dwell time @235°C	60	sec
Temperature drop in cooling Area	-1 to - 4	°C/sec
Max dwell time above 100°C	420	sec

Issue : 0424 D

In the effort to improve our products, we reserve the right to make changes judged to be necessary.



**STRAIGHT JACK RECEPTACLE FOR PCB**

**R113.423.000**

**SMT TYPE - EDGE CARD**

Series : MCX

**MCX SERIES - INFORMATIONS**

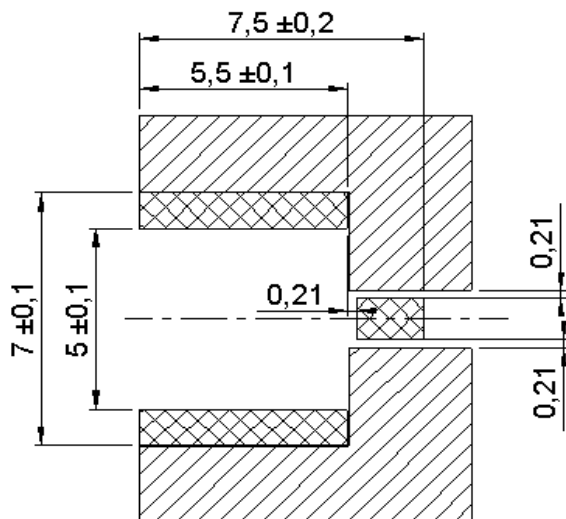

 Pattern

 Land for solder paste

**COPLANAR LINE**

Pattern and signal are on the same side

Thickness of PCB : 1.6mm

The material of PCB is the epoxy resin of glass fabrics bacs.(En -4.8)

The solder resist should be printed except for the land pattern on the PCB.

**SHADOW OF MCX RECEPTACLE FOR VIDEO CAMERA**

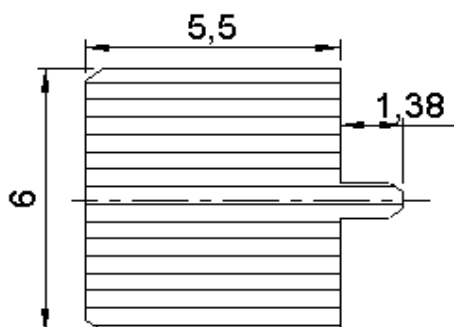

Issue : 0424 D

In the effort to improve our products, we reserve the right to make changes judged to be necessary.

