

# LINOS F-Theta-Ronar Lens

$f = 167\text{mm}$ , 1030-1080nm, telecentric, fused silica, low absorption

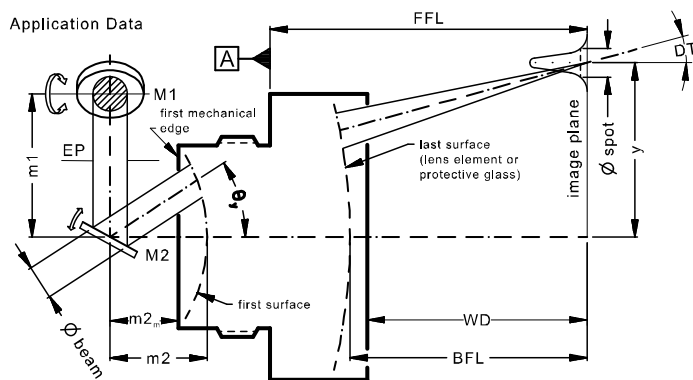

Part number	4401-513-000-26			
Design wavelength	$\lambda$	(nm)	1064	
Effective focal length	EFL	(mm)	167.3	
Back focal length	BFL	(mm)	217.9	
Working distance	WD	(mm)	215.4	
Flange focal length	FFL	(mm)	313.2	
Beam diameter 1/e <sup>2</sup> truncated	$\varnothing_{\text{beam}}$	(mm)	14.0	20.0
Recommended mirror distance m1	m1	(mm)	17.0	25.6
Recommended mirror distance m2	m2	(mm)	28.0	28.0
Recommended mirror distance m2 <sub>mechanical</sub>	m2 <sub>m</sub>	(mm)	22.3	22.3
Scan angle	$\pm\theta_{x,y}$	(°)	15.2	14.9
Scan area (edge length of scan field)	2x * 2y	(mm <sup>2</sup> )	85 x 85	84 x 84
Spot diameter	$\varnothing_{\text{spot}}$	( $\mu\text{m}$ )	23	16
Telecentric error (maximum deviation)	DT	(°)	4.3	3.7
Total transmission @ 1030 - 1080nm	T	(%)	> 96	
Group delay dispersion at $\lambda$	GDD	(fs <sup>2</sup> )	1198	
LIDT coating @ 1064nm, 12ns, 100Hz		(J/cm <sup>2</sup> )	40	
LIDT coating @ 1030nm, 291fs, 5kHz		(J/cm <sup>2</sup> )	0.9	
Focused back reflex positions from first surface		(mm)	4.0; 7.6; 12.0; 12.3; 15.4; 16.0; 38.3	
Weight		(g)	2100	
Protective glass	PG		4401-513-006-00	

Optical parameters calculated for a 1-mirror system  
 Subject to technical change

## Mechanical drawing

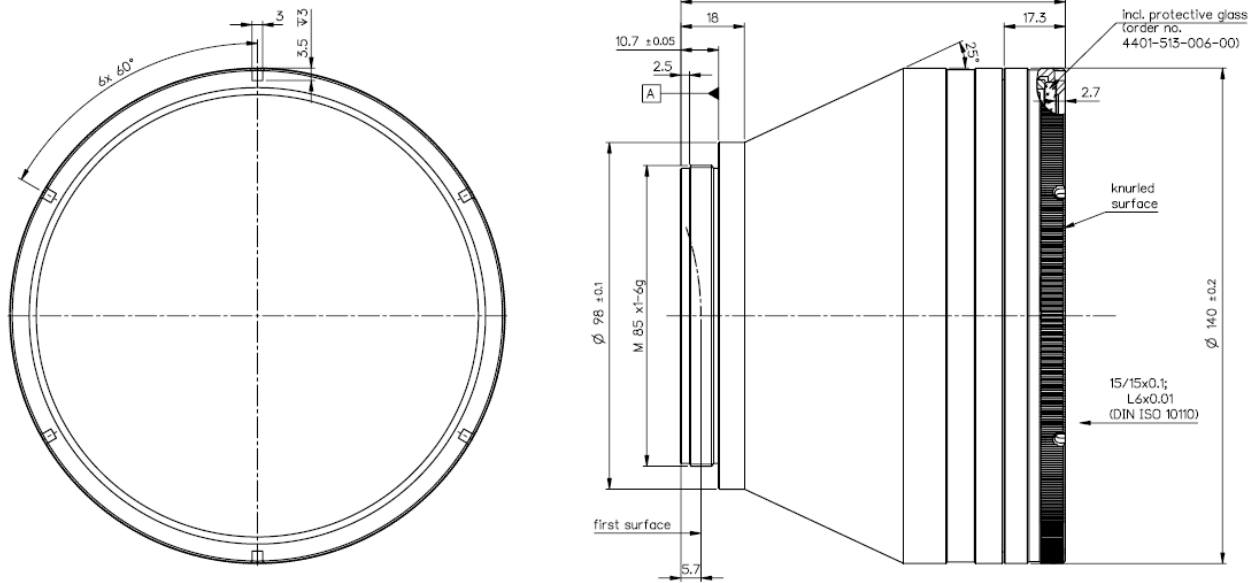

Dimensions without tolerances are nominal values and illustration not to scale

## Spot variation over scanfield

Spot radius in  $\mu\text{m}$  at  $1/e^2$  level for a Gaussian laser beam ( $M^2=1$ )

field size and mirror distances as given above for a 2 mirror scan system, vignetting  $\leq 1\%$

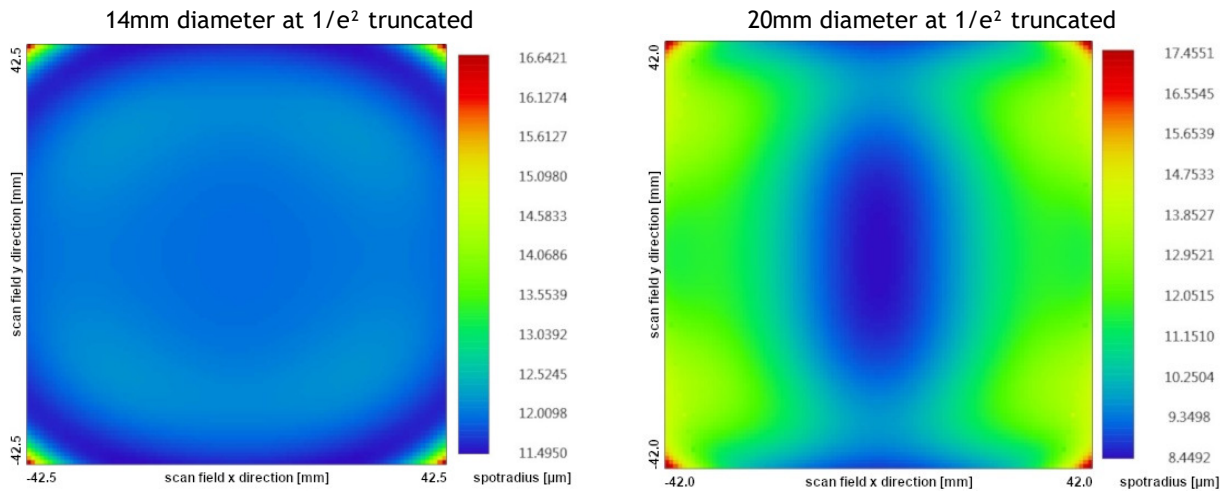

## Notes:



For technical explanations, see our homepage.

In a 1-mirror system, the entrance pupil (EP) is the position of the scan mirror. In a 2-mirror system, it is the point where the scan mirrors should be placed around symmetrically to reach specified performance.