

# 3M™ Sheath Seal Kits, 5831 and 5832

For multi-conductor cables with or without ground wires

## Installation Instructions

### 1.0 Kit Contents:

5831	5832	
1	1	Mold Body
1	1	Mold Strap
1	1	Strap Support
1	1	Strip Spacer Web
1	2	Roll(s) Scotch® Linerless Rubber Splicing Tape 130C
1	1	Roll Scotch® Super 33+™ Vinyl Electrical Tape
1	1	Roll 3M™ Scotchfil™ Electrical Insulating Putty
1	2	Size "C" Bag, 3M™ Scotchcast™ Flame-Retardant Compound 2131
1	1	Strip 3M™ Three-M-Ite™ Elek-Tro-Cut™ Abrasive Cloth
1	1	3M™ Cable Cleaning Preparation Kit CC-2

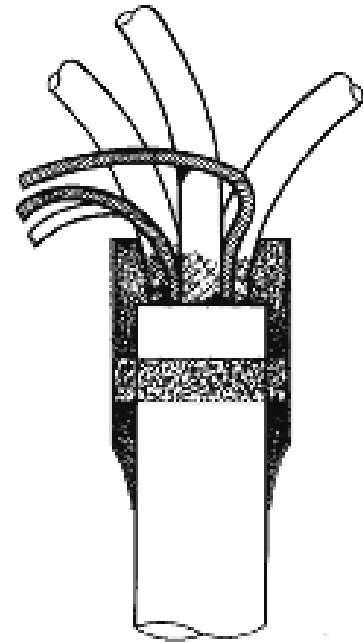

Kit No.	Conductor Size Range (AWG)	Maximum Jacket (or Amor) O.D.
5831	2 – 3/0	2.60 in. (66,0 mm)
5832	4/0 – 500 kcmil	3.75 in. (95,3 mm)

**DANGER:** BEFORE ATTEMPTING ANY CABLE REPAIRS, MAKE SURE THAT THE PROPER CABLE IS DISCONNECTED, LOCKED OUT AND SUITABLY TAGGED.



Working around energized systems may cause serious injury or death. Installation should be performed by personnel familiar with good safety practice in handling electrical equipment. De-energize and ground all electrical systems before installing product.

<b>Technical Information:</b>  For use on shielded and non-shielded multi-conductor Cables  Cable Size Range (copper & aluminum)  5831 - 2 to 3/0 AWG 5832 - 4/0 AWG to 500 kcmil	<b>3M™</b> <b>Sheath Seal Kits</b>  For multi-conductor cables with or without ground wires  <b>5831 and 5832</b>
	<b>78-8126-9791-6</b>

April, 2011

## 2.0 Prepare Cable

- 2.1 Remove cable jacket and/or armor; field determine removal length according to spacing requirements, etc. (Figure 1)
- 2.2 Remove cable fillers back to the cable jacket and/or armor.
- 2.3 Remove shield per instructions for terminating device.

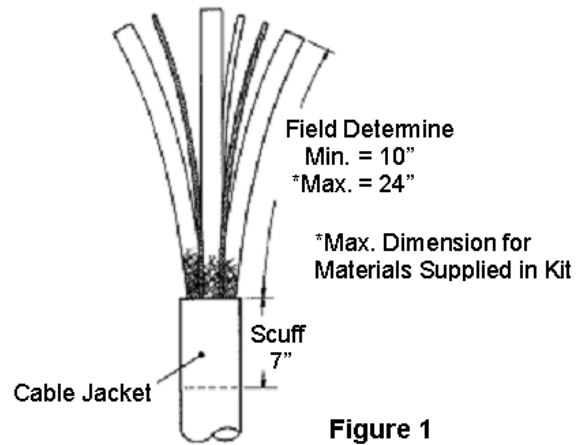

- 2.4 Starting 1½" (38 mm) from cable jacket (or armor), apply two highly elongated half-lapped layers of Scotch® Linerless Rubber Splicing Tape 130C over the shielding, leaving the end of the shielding exposed for the distance as indicated in the instructions for the termination device. (Figure 2)

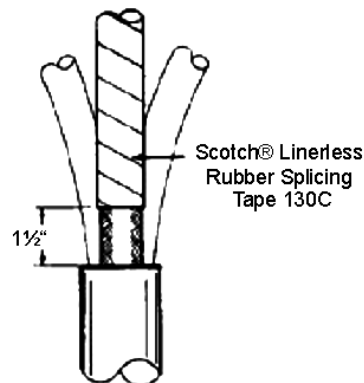

**Figure 2**

- 2.5 Apply a half-lapped layer of Scotch® Super 33+™ Vinyl Electrical Tape over previously applied Scotch® Tape 130C. (Figure 3)

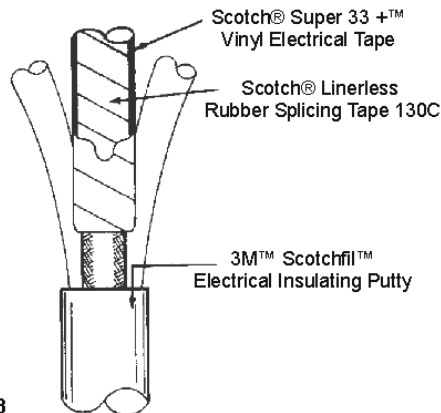

**Figure 3**

- 2.6 Install terminating device per manufacturer's recommendations.
- 2.7 If void spaces exist at the jacket or armor cut off, fill spaces with pieces of 3M™ Scotchfil™ Electrical Insulating Putty to prevent resin from running down cable with resin poured.

### 3.0 Install Cable Crotch Seal

- 3.1. THOROUGHLY scuff jacket or armor and end for 7" (180 mm). Clean dust from scuffed area. (Figure 1)
- 3.2. Untwist and open ropes of ground wires to within 2" (50 mm) of cable jacket end to allow for seal.
- 3.3. Scuff ground check wire insulation for a minimum distance of 2½" (64 mm) from cable jacket end.
- 3.4. Position spacer web collar 1½" (37 mm) from edge of cable jacket. (Figure 4)
- 3.5. Wrap spacer web 1 ¼ wraps and cut off. Split the ¼ overlap of spacer web and press into sides to hold in place. (Figure 4)

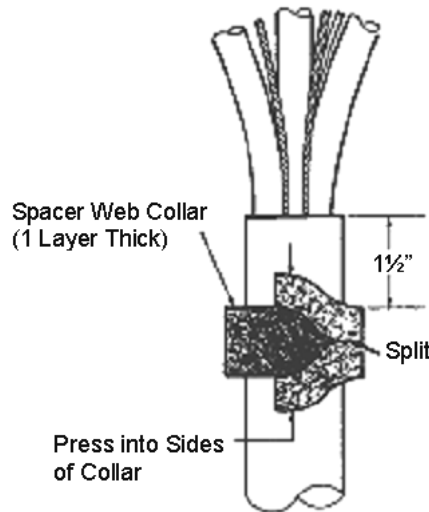

Figure 4

- 3.6. Seal vent slits on outside of mold with Scotch® Super 33+™ Vinyl Electrical Tape.
- 3.7. With cable straight, position mold over spacer web collar, extending 2½" (64 mm) beyond end of cable jacket. (Figure 5)

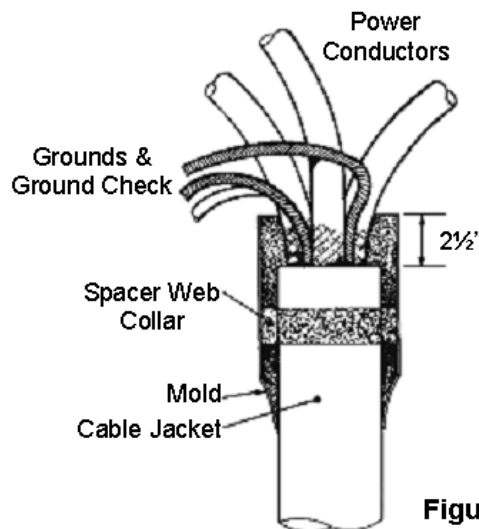

Figure 5

- 3.8. Wrap firmly around, tucking one edge under.

**NOTE:** Tucked edge must be straight to form a seal.

3.9 Position strap support on mold, locating it over the spacer web collar. Secure firmly with mold strap. (Figure 6)

**NOTE:** At this time, strap support and mold strap may be moved to adjust for a uniform cylindrical shape.

3.10 Bundle mold's notched edge evenly around cable, maintaining cable centering. Starting ½" (12 mm) on cable jacket, apply a half-lapped layer to Scotch® Linerless Rubber Splicing Tape 130C over the notches. (Figure 6)

**NOTE:** Apply Scotch® Tape 130C with tacky side up, with only enough tension to conform to mold.

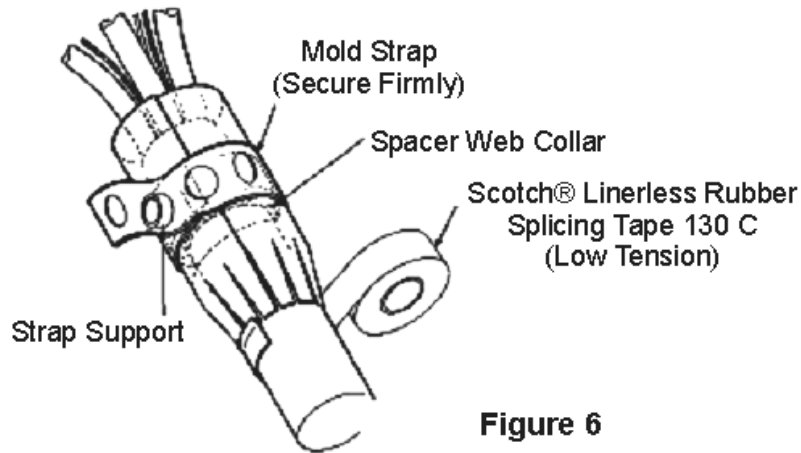

**Figure 6**

3.11 With cable end mounted vertically, arrange individual conductors and ground into final position. Allow a minimum clearance of ¼" (6 mm) from edge of mold body. (Figure 5)

#### 4.0 Pour Compound

4.1 Premix BLACK side of 3M™ Scotchcast™ Flame-Retardant Compound 2131 by squeezing to a smooth consistency and uniform color.

4.2 Firmly grasp each flat side of the closed mixing pouch near the center barrier; at the same time pull sides of barrier apart and roll sides of thumbs through barrier. Break the barrier all the way across to the side seals. (Figure 7)

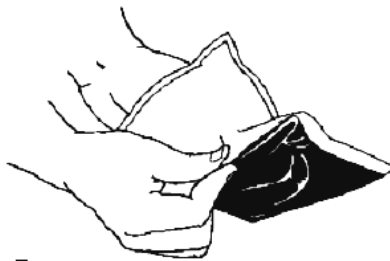

**Figure 7**

4.3 Alternately squeeze ends of pouch forcing compound rapidly back and forth, strip compound from corners of pouch between fingers. Mix until color is completely uniform – 30 to 40 VIGOROUS SQUEEZES. DO NOT EXCEED 1 MINUTE. (Figure 8)

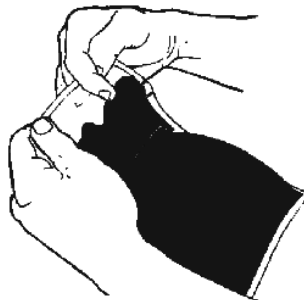

**Figure 8**

4.4 Clip off a corner of pouch and immediately pour into open top of mold. Fill mold to top edge.

4.5 Allow compound to cure.

**NOTE:** *Crotch seal may be de-molded when compound is no longer tacky.*

**Typical Cure Time:** 16 – 24 hrs. @ 70°F (21°C)  
24 – 30 hrs. @ 50°F (10°C)  
36 hrs. @ 32°F (0°C)

**Typical De-mold Time:** 1.5 hrs. @ 70°F (21°C)  
4 hrs. @ 50°F (10°C)  
6 – 8 hrs. @ 32°F (0°C)

**NOTE:** *Values are typical, not to be considered minimum or maximum. Always confirm based on tack and hardness of compound that resin is sufficiently cured.*

## 5.0 De-mold

5.1 Remove mold strap and funnel support.

5.2 Remove Scotch® Linerless Rubber Splicing Tape 130C and mold end.

5.2 Remove mold from cable crotch seal.

3M, Scotchcast, Scotchfil, Super 33+, Three-M-lte and Elek-Tro-Cut are trademarks of 3M Company. Scotch is a registered trademark of 3M Company.

### Important Notice:

All statements, technical information, and recommendations related to 3M's products are based on information believed to be reliable, but the accuracy or completeness is not guaranteed. Before using this product, you must evaluate it and determine if it is suitable for your intended application. You assume all risks and liability associated with such use. Any statements related to the product, which are not contained in 3M's current publications, or any contrary statements contained on your purchase order, shall have no force or effect unless expressly agreed upon, in writing, by an authorized officer of 3M.

### Warranty; Limited Remedy; Limited Liability:

This product will be free from defects in material and manufacture at the time of purchase. 3M MAKES NO OTHER WARRANTIES INCLUDING, BUT NOT LIMITED TO, ANY IMPLIED WARRANTY OF MERCHANTABILITY OR FITNESS FOR A PARTICULAR PURPOSE. If this product is defective within the warranty period stated above, your exclusive remedy shall be, at 3M's option, to replace or repair the 3M product or refund the purchase price of the 3M product. Except where prohibited by law, 3M will not be liable for any indirect, special, incidental or consequential loss or damage arising from this 3M product, regardless of the legal theory asserted.



Electrical Markets Division  
6801 River Place Blvd.  
Austin, TX 78726-9000  
800.245.3573  
Fax 800.245.0329  
[www.3M.com/electrical](http://www.3M.com/electrical)

Please Recycle. Printed in USA.  
© 3M 2011 All Rights Reserved.  
78-8126-9791-6 A