

THIS DRAWING IS UNPUBLISHED. RELEASED FOR PUBLICATION
 © COPYRIGHT BY TYCO ELECTRONICS CORPORATION. ALL INTERNATIONAL RIGHTS RESERVED.

LOC	DIST	REVISIONS					
AF	50	P	LTR	DESCRIPTION	DATE	DWN	APVD
		G		REVISED PER ECR-10-006099	07JUL10	HMR	PD

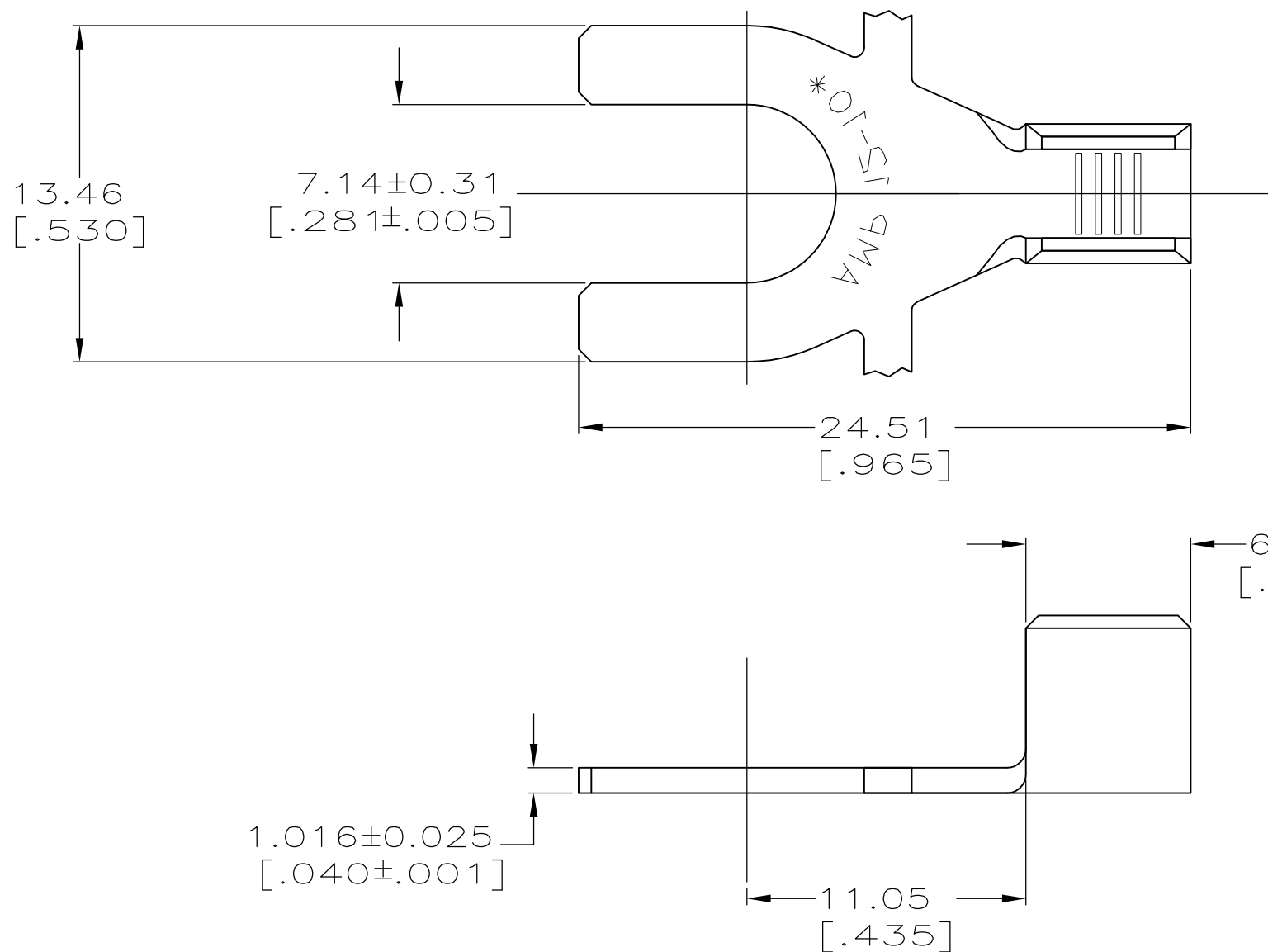

1. CONTINUOUS STRIP ON REELS

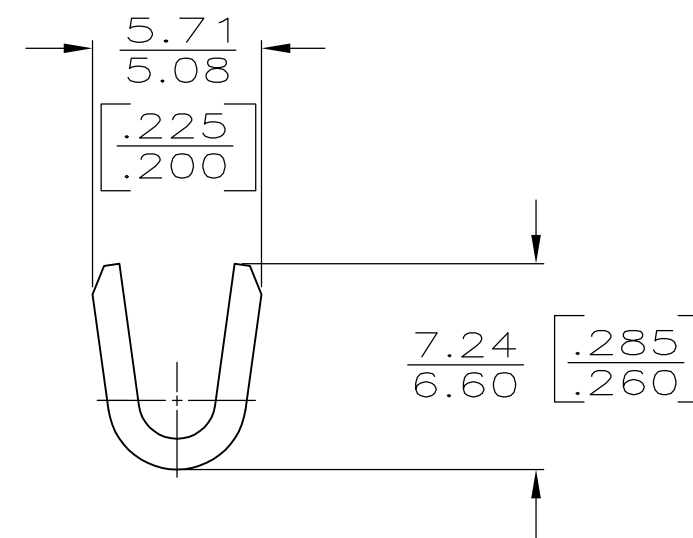

3.0mm ² - 6.0mm ² [12-10] AWG	60313-2
WIRE RANGE	PART NO

F	4.57 [.180]	3.78 [149]	6.0mm ² [10]
		3.40 [134]	3.0mm ² [12]
TYPE	WIDTH	±0.051 [E.002] HEIGHT	WIRE
WIRE BARREL CRIMP			

THIS DRAWING IS A CONTROLLED DOCUMENT.	
DIMENSIONS: mm [INCHES]	TOLERANCES UNLESS OTHERWISE SPECIFIED:
	0 PLC ± -
	1 PLC ± -
	2 PLC ± -
	3 PLC ± 0.38 [015]
4 PLC ± -	± -
MATERIAL #1 HARD BRASS	FINISH TIN

DWN P FORTNEY 12/1/89	 Tyco Electronics Corporation Harrisburg, PA 17105-3608	NAME		RESTRICTED TO
CHK MS FEHER 12/1/89		SPADE		
APVD G YETTER 12/1/89		SIZE	CAGE CODE	
PRODUCT SPEC	A300779		C-60313	
APPLICATION SPEC	CUSTOMER DRAWING		SCALE 4:1	SHEET 1 OF 1
WEIGHT	-		REV G	