

NOTES:

1. ROHS COMPLIANT
2. PLASTIC HOUSING: THERMOPLASTIC MATERIAL WITH FLAMMABILITY RATING UL 94V-0 OR BETTER.
3. CONTACTS PLATING: 30 μINCHES GOLD PLATING.
4. CONTACTS BASE MATERIAL: PHOSPHOR BRONZE
5. UNDER PLATING: 30-50 μINCHES NICKEL
6. SOLDER TAIL PLATING : 200-500 μINCHES 100% TIN, MATTE FINISH.
7. METAL SHIELD: NICKEL PLATING ON COPPER ALLOY.
8. JACK CAVITY CONFORMS TO FCC PART 68 SUBPART.
9. PCB PLATING: HASL (TOP PCB), ENIG (BOTTOM PCB)
10. STORAGE TEMPERATURE: -20°C TO +125°C
11. COMPLIANCE TO J-STD:
 - A. J-STD-002: SOLDERABILITY AT 245°C DIP AND LOOK TEST
 - B. J-STD-020: LEVEL 1, NO MOISTURE SENSITIVE
 - C. J-STD-075: W2, 270°C MAXIMUM THROUGH WAVE SOLDER

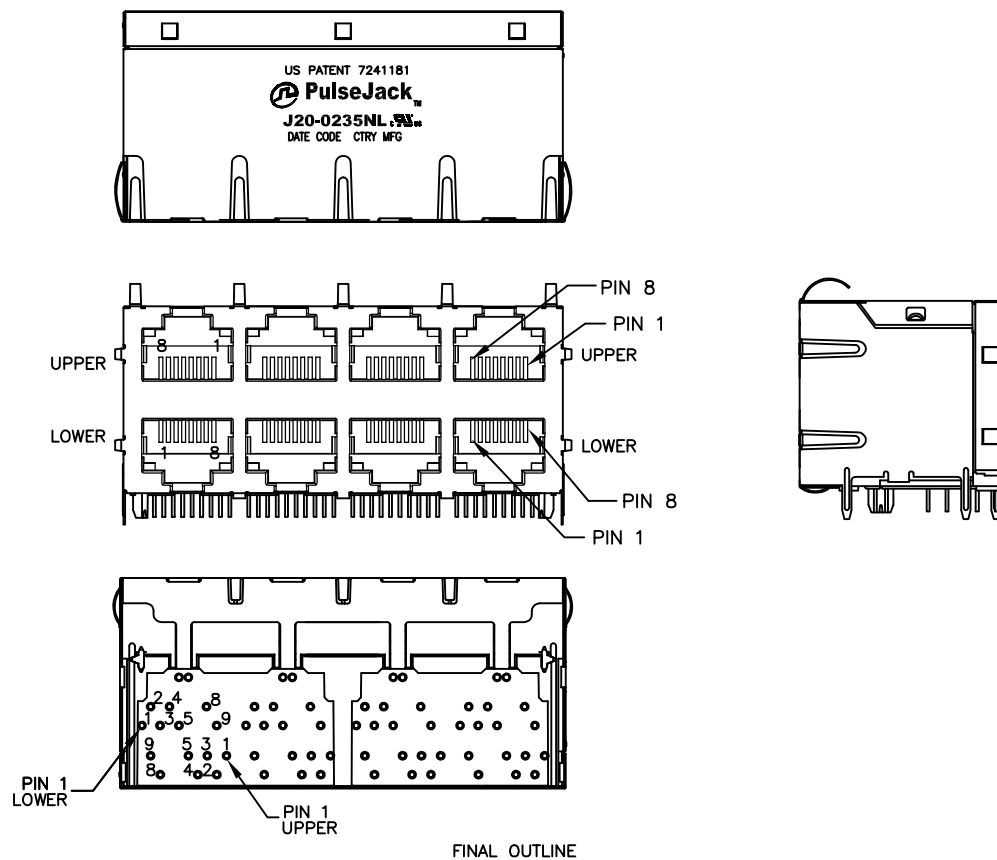

© Copyright, 2015. Pulse Electronics Corp. All rights reserved. Pulse confidential & proprietary. (12/10/15)

PRODUCT DESCRIPTION	TLA DRAWING	PS DRAWING	SHEET	PART NO.	DATASHEET REV.
CONN,RJ45,2X4,100PP,1:1,TY	J20-0235NL-11	PS-2315.212-C	1 OF 4	J20-0235NL	A

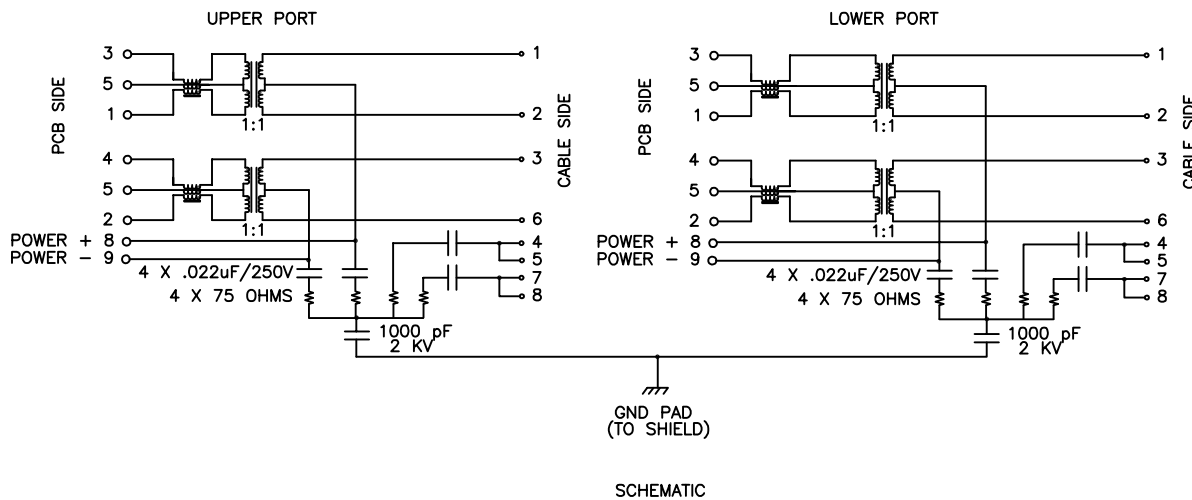

ELECTRICAL CHARACTERISTICS AT +25°C UNLESS OTHERWISE SPECIFIED
(FOR REFERENCE ONLY. USED FOR CUSTOMER INFORMATION.)

PARAMETER	SPECIFICATION		
OPERATING TEMP	0°C TO +70°C		
TURNS RATIO	1 : 1 ±2%		
POLARITY	PER SCHEMATIC		
INSERTION LOSS	100 KHz	1-125 MHz	
	-1.2 dB MAX	-0.2-0.002*f ^{1.4} dB MAX	
RETURN LOSS (Z _{out} = 100 OHM ±15%)	.1-30 MHz	30-60 MHz	60-80 MHz
	-16 dB MIN	-10+20*LOG ₁₀ (f/60 MHz) dB MIN	-10 dB MIN
	INDUCTANCE (OCL) (MEDIA SIDE, 0°C TO +70°C)		
CROSSTALK, ADJACENT CHANNELS	1 MHz	10-100 MHz	
	-50 dB MIN	-55+22*LOG ₁₀ (f/10) dB MIN	
COMMON MODE REJECTION RATIO	2 MHz	30-200 MHz	
	-50 dB MIN	-15+20*LOG ₁₀ (f/200) dB MIN	
INPUT - OUTPUT ISOLATION	2250 VDC MIN @ 60 SECONDS		

NOTE: f IS FREQUENCY IN MHz.

© Copyright, 2015. Pulse Electronics Corp. All rights reserved. Pulse confidential & proprietary. (12/10/15)

PRODUCT DESCRIPTION	TLA DRAWING	PS DRAWING	SHEET	PART NO.	DATASHEET REV.
CONN,RJ45,2X4,100PP,1:1,TY	J20-0235NL-11	PS-2315.212-C	2 OF 4	J20-0235NL	A

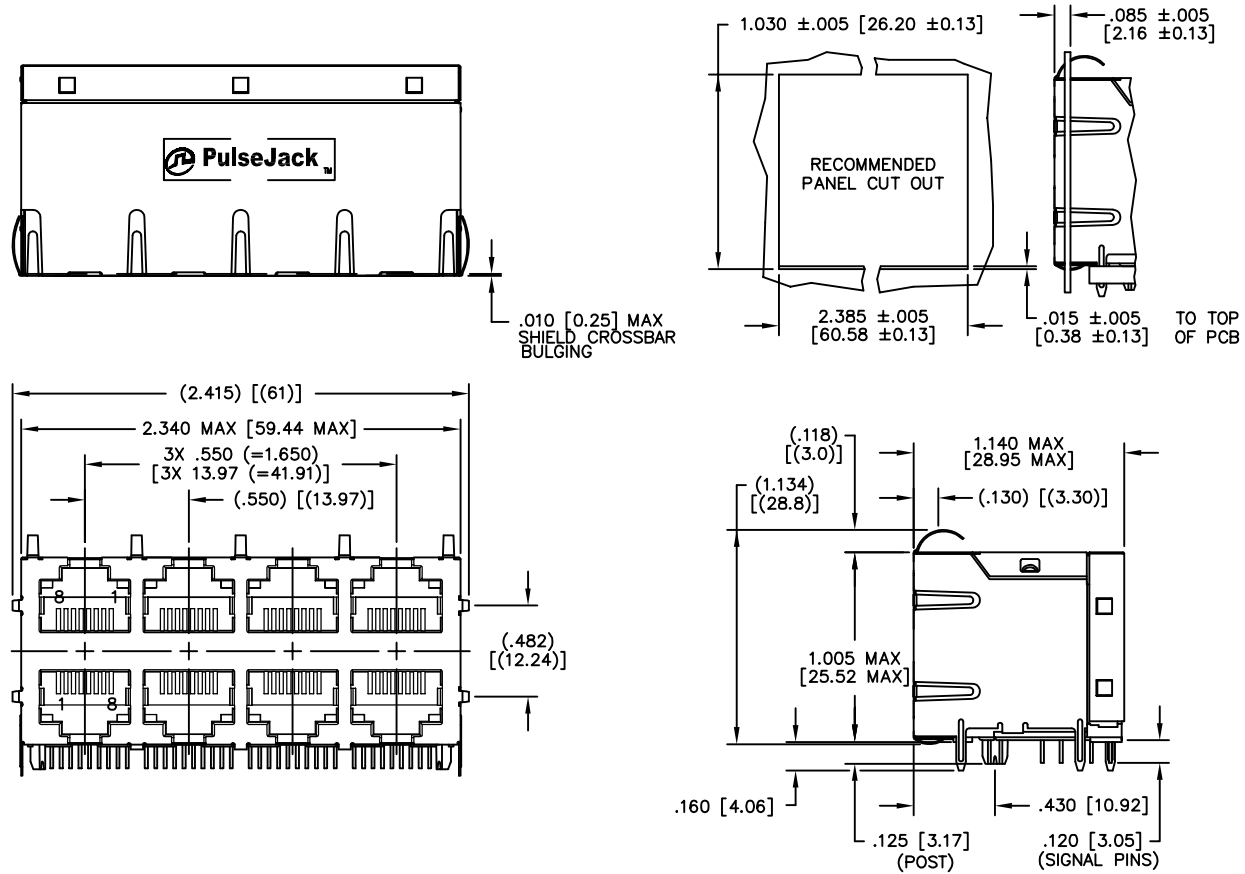

DIMENSIONS ARE IN INCHES [MILLIMETERS] WITH THE FOLLOWING TOLERANCES: [MILLIMETERS] ARE FOR REFERENCE ONLY.
 .XX= $\pm .02$ [± 0.5]
 .XXX= $\pm .010$ [± 0.25]

© Copyright, 2015, Pulse Electronics Corp. All rights reserved. Pulse confidential & proprietary. (12/10/15)

PRODUCT DESCRIPTION	TLA DRAWING	PS DRAWING	SHEET	PART NO.	DATASHEET REV.
CONN,RJ45,2X4,100PP,1:1,TY	J20-0235NL-11	PS-2315.212-C	3 OF 4	J20-0235NL	A

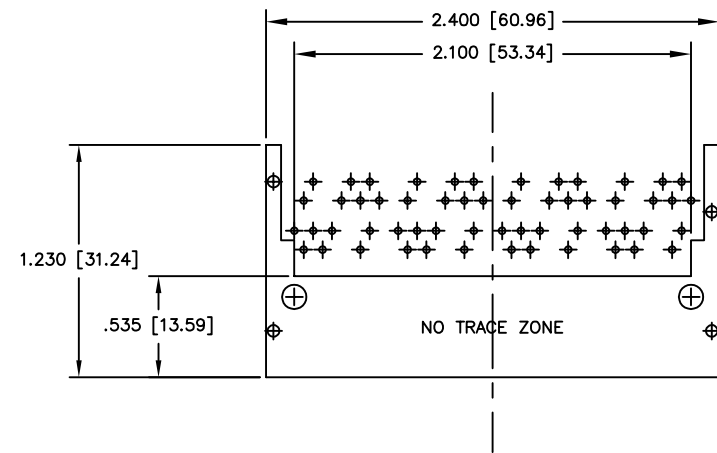
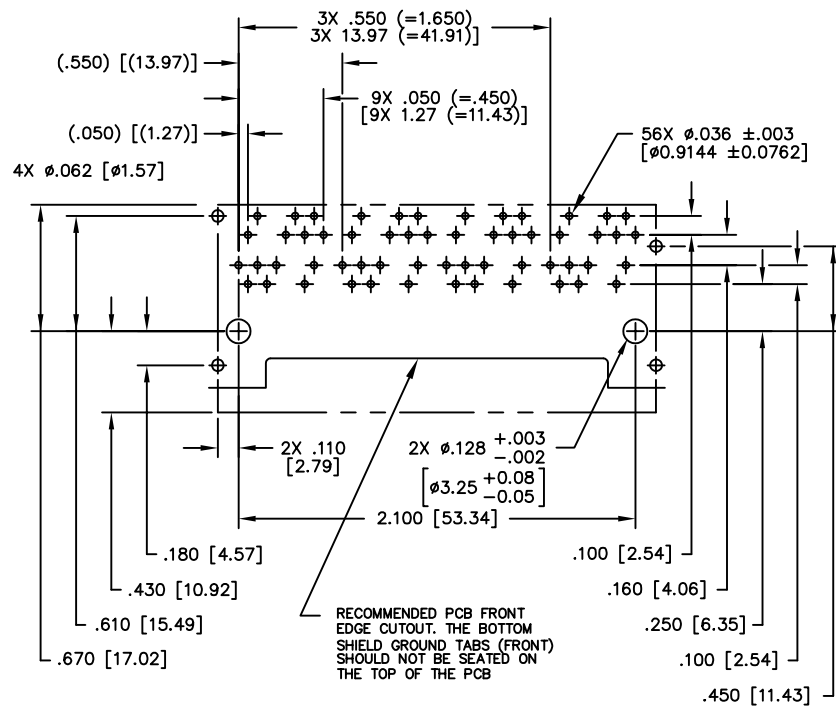

SUGGESTED PC BOARD LAYOUT VIEWED FROM COMPONENT SIDE
UNLESS OTHERWISE SPECIFIED DIMENSIONAL TOLERANCE IS ± 0.02

DIMENSIONS ARE IN INCHES [MILLIMETERS] WITH THE FOLLOWING
TOLERANCES: [MILLIMETERS] ARE FOR REFERENCE ONLY.
.XX = ± 0.02 [± 0.5]
.XXX = ± 0.010 [± 0.25]

© Copyright, 2015, Pulse Electronics Corp. All rights reserved. Pulse confidential & proprietary. (12/10/15)

PRODUCT DESCRIPTION	TLA DRAWING	PS DRAWING	SHEET	PART NO.	DATASHEET REV.
CONN,RJ45,2X4,100PP,1:1,TY	J20-0235NL-11	PS-2315.212-C	4 OF 4	J20-0235NL	A