













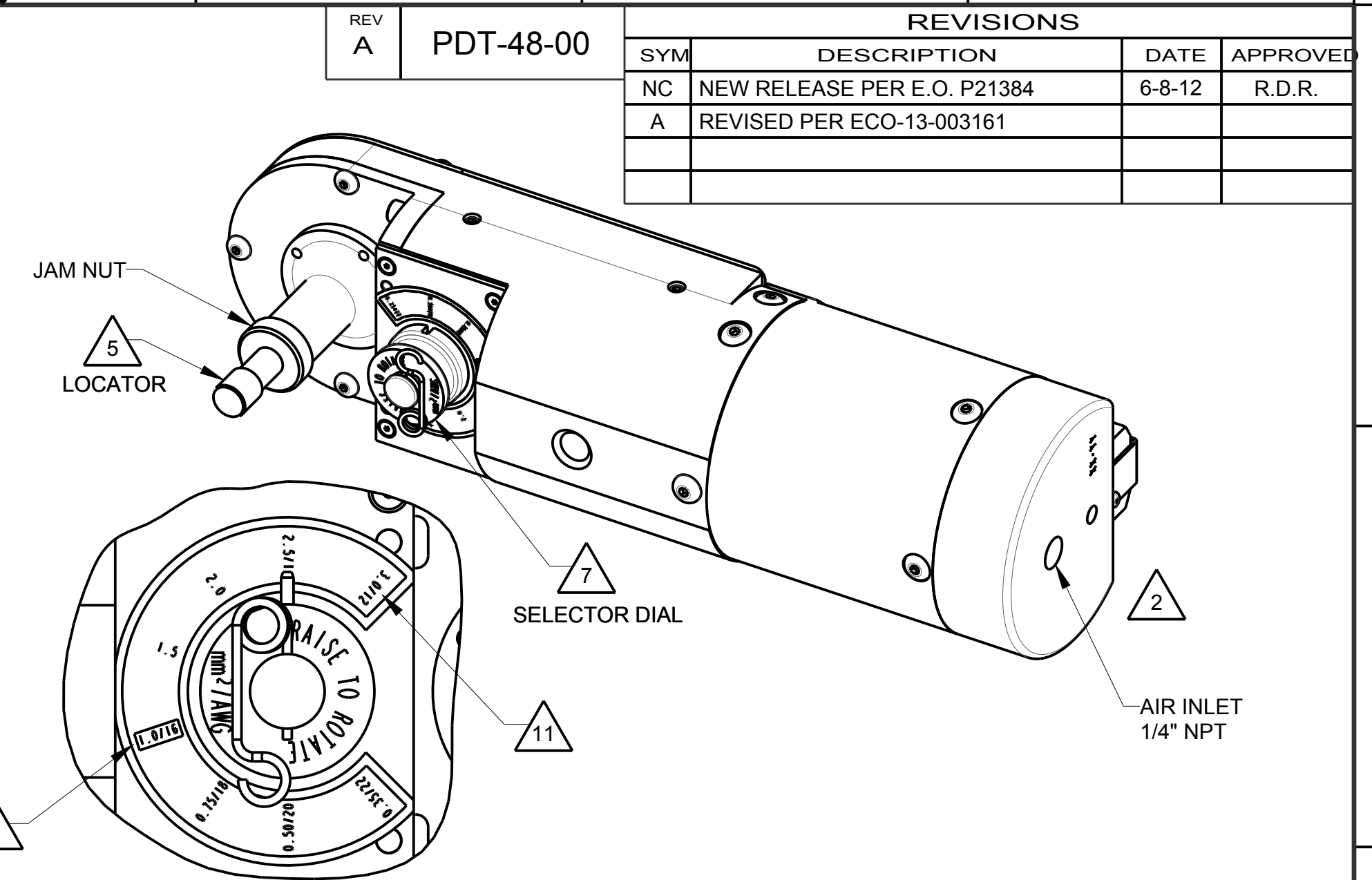



7	6	5	4	3	2	1
SOLID CONTACT PART NUMBER 	SIZE TYPE	WIRE SIZE AWG [mm²]	REF. ONLY CRIMP TENSILE LBS [N]	RECOMMENDED STRIP LENGTH INCH [mm]	CONTACT IDENTIFICATION INFO & NOTES	
0460-204-12** 0460-211-12** 0460-220-12** 0460-235-12** 0460-258-12** 0462-203-12** 0462-210-12** 0462-214-12** 0462-215-12**	12 PIN 12 PIN 12 PIN 12 PIN 12 SOC 12 SOC 12 SOC 12 SOC 12 SOC	12 AWG 3.0 mm² 12 AWG 2.5 mm² 14 AWG 2.0 mm²	75 [334] 70 [311]	.222-.284 [5.64-7.21]	0462-215-12** MARKING 1 GRAY BAND, NARROW 1 BROWN BAND, NARROW 1 BROWN BAND, BROAD	
0460-256-12**	12 PIN	1.5 mm² 16 AWG 1.0 mm² 18 AWG 0.75 mm²	35 [156] 25 [111]	.222-.284 [5.64-7.21]		
0460-215-16** 0462-209-16**	16 PIN 16 SOC	14 AWG 2.0 mm²	70 [311]	.250-.312 [6.35-7.92]	1 GREEN BAND, BROAD 1 GREEN BAND, BROAD	
0460-002-16** 0460-202-16** 0460-211-16** 0460-230-16** 0460-235-16** 0460-247-16** 0462-004-16** 0462-007-16** 0462-201-16** 0462-214-16** 0462-221-16** 0462-222-16**	16 PIN 16 PIN 16 PIN 16 PIN 16 PIN 16 SOC 16 SOC 16 SOC 16 SOC 16 SOC 16 SOC 16 SOC	1.5 mm² 16 AWG 1.0 mm² 18 AWG 0.75 mm² 20 AWG 0.50 mm²	35 [156] 25 [111] 20 [89]	.250-.312 [6.35-7.92]	0460-002-1631 AND 0462-004-1631 MARKING 1 BLUE BAND, BROAD	
0462-001-16**	16 SOC	16 AWG 1.0 mm²	35 [156]	.250-.312 [6.35-7.92]	1 BLUE BAND, NARROW	
0462-223-16**	16 SOC	1.5 mm² 16 AWG 1.0 mm²	35 [156]	.117-.237 [4.49-6.02]	USE 2.0 mm² DIAL SET	
0460-010-20** 0462-005-20**	20 PIN 20 SOC	16 AWG 1.00 mm² 18 AWG 0.75 mm²	20 [89]	.156-.218 [3.96-5.54]	1 PURPLE BAND, BROAD	
0460-202-20** 0462-201-20**	20 PIN 20 SOC	20 AWG 0.50 mm² 22 AWG 0.35 mm²	20 [89] 10 [44]	.156-.218 [3.96-5.54]		
112349 112352	12 PIN 12 SOC	12 AWG 3.0 mm² 14 AWG 2.0 mm²	75 [334] 70 [311]	.222-.284 [5.64-7.21]	SLOTTED (SPLIT) PIN  	
0460-201-1690 0461-201-1690	16 PIN 16 SOC	1.5 mm² 16 AWG 1.0 mm² 18 AWG 0.75 mm²	35 [156] 25 [111]	.222-.284 [5.64-7.21]	SLOTTED (SPLIT) PIN	
8960-025-12603 8962-014-12603	12 PIN 12 SOC	4.0 mm² 12 AWG 3.0 mm² 2.5 mm²	75 [334]	.222-.284 [5.64-7.21]		
8960-020-16603 8962-011-16603	16 PIN 16 SOC	1.5 mm² 16 AWG 1.0 mm² 18 AWG 0.75 mm² 20 AWG 0.50 mm²	35 [156] 25 [111] 20 [89]	.250-.312 [6.35-7.92]		



SOLID CONTACT PART NUMBER 	SIZE TYPE	WIRE SIZE AWG [mm²]	REF. ONLY CRIMP TENSILE LBS [N]	RECOMMENDED STRIP LENGTH INCH [mm]	CONTACT IDENTIFICATION INFO & NOTES
4060-002-12** 4062-002-12**	12 PIN 12 SOC	12 AWG 3.0 mm² 14 AWG 2.0 mm²	75 [334] 70 [311]	.250-.312 [6.35-7.92]	 
4060-001-16** 4062-001-16**	16 PIN 16 SOC	1.5 mm² 16 AWG 1.0 mm² 18 AWG 0.75 mm²	35 [156] 25 [111]	.240-.302 [6.10-7.67]	

13. OPTIONAL FOOT VALVE PART NUMBER: WA10A (SOLD SEPARATELY). AVAILABLE FROM: DANIELS MANUFACTURING COMPANY; 526 THORPE ROAD; ORLANDO, FL 32824-8133; PHONE: 407-855-6161.
12. OPTIONAL BASE MOUNT PART NUMBER: BM-2A (SOLD SEPARATELY). SEE SHEET 2. AVAILABLE FROM: DANIELS MANUFACTURING COMPANY; 526 THORPE ROAD; ORLANDO, FL 32824-8133; PHONE: 407-855-6161.
-  USE 3.0/12 SETTING FOR THIS PART WITH 4.0mm².
10. 9 FOOT AIR HOSE WITH 1/4" NPT CONNECTOR SUPPLIED WITH TOOL IN A SEPARATE BAG, PART NUMBER: 12-3001.
9. SEE 0425-079-0000 INSTRUCTION GUIDE, SHIPPED WITH TOOL.
8. OVERALL TOOL LENGTH IS APPROXIMATELY 9.88 [250.82].
-  CYCLE TOOL TO OPEN INDENTERS. REMOVE LOCK CLIP. RAISE AND ROTATE DIAL TO SELECT WIRE SIZE. REPLACE LOCK CLIP.
-  WHEN ** = 31, PLATING IS GOLD.
WHEN ** = 141, PLATING IS NICKEL.
WHEN ** = 309, PLATING IS TIN.
(CONTACT FACTORY FOR AVAILABILITY)

-  DEPTH ADJUSTING SCREW P/N 0426-209-0000 INCLUDES JAM NUT.
-  USE 2.5/14 SETTING FOR THIS PART WITH 12 AWG.
-  USE 1.5 SETTING FOR THIS PART WITH 14 AWG.
-  CAUTION: NEVER CLOSE TOOL ON GAGE G454. CLOSE TOOL FIRST AND THEN INSERT GAGE.
-  USE GAGE G454 IN DIAL POSITION 1.0/16 TO CHECK WEAR ANNUALLY. CHECK OFTEN IF USED FOR FREQUENT CRIMPING.
- NOTES: UNLESS OTHERWISE SPECIFIED

SIGNATURE & DATE		TOOL, PNEUMATIC CRIMP FOR SIZE 20, 16 & 12 SOLID CONTACTS	EP	MATL. CODE
DR	J.APOSTOL 25APR2012		3850 INDUSTRIAL AVE. HEMET, CA 92545	
CHK	D. MEYER 2/21/13		DEUTSCH INDUSTRIAL	
PE	D. MEYER 2/21/13		PDT-48-00	
APPD	D. MEYER 2/21/13	ENVELOPE	DWG SIZE	CODE 11139
SCALE	NONE		WT	SHEET 1 OF 2

7

6

5

4



3

2

1

REV A	PDT-48-00	REVISIONS		
SYM	DESCRIPTION	DATE	APPROVED	
A	SEE SHEET 1			

E

E

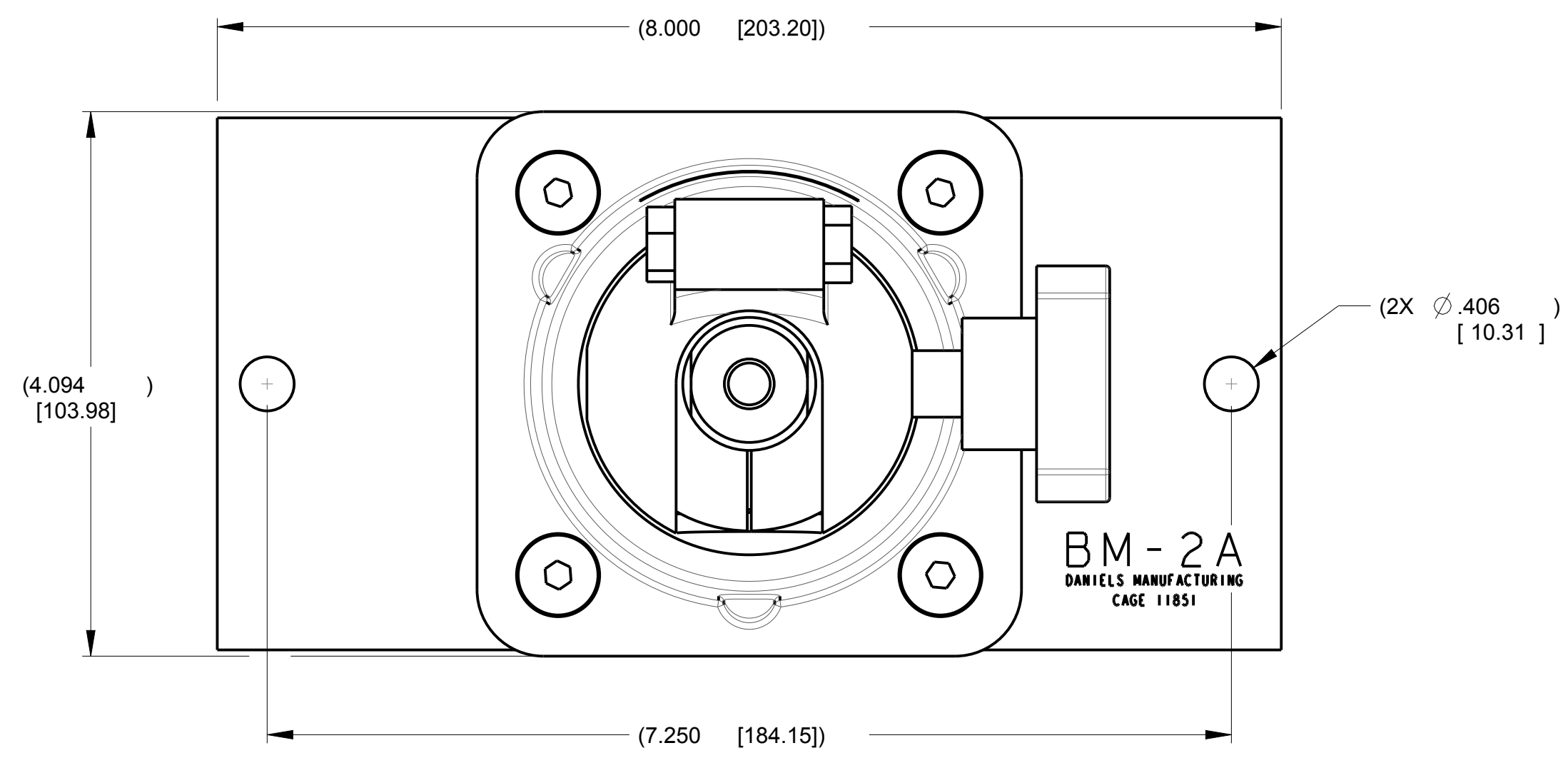

D

D



C

C

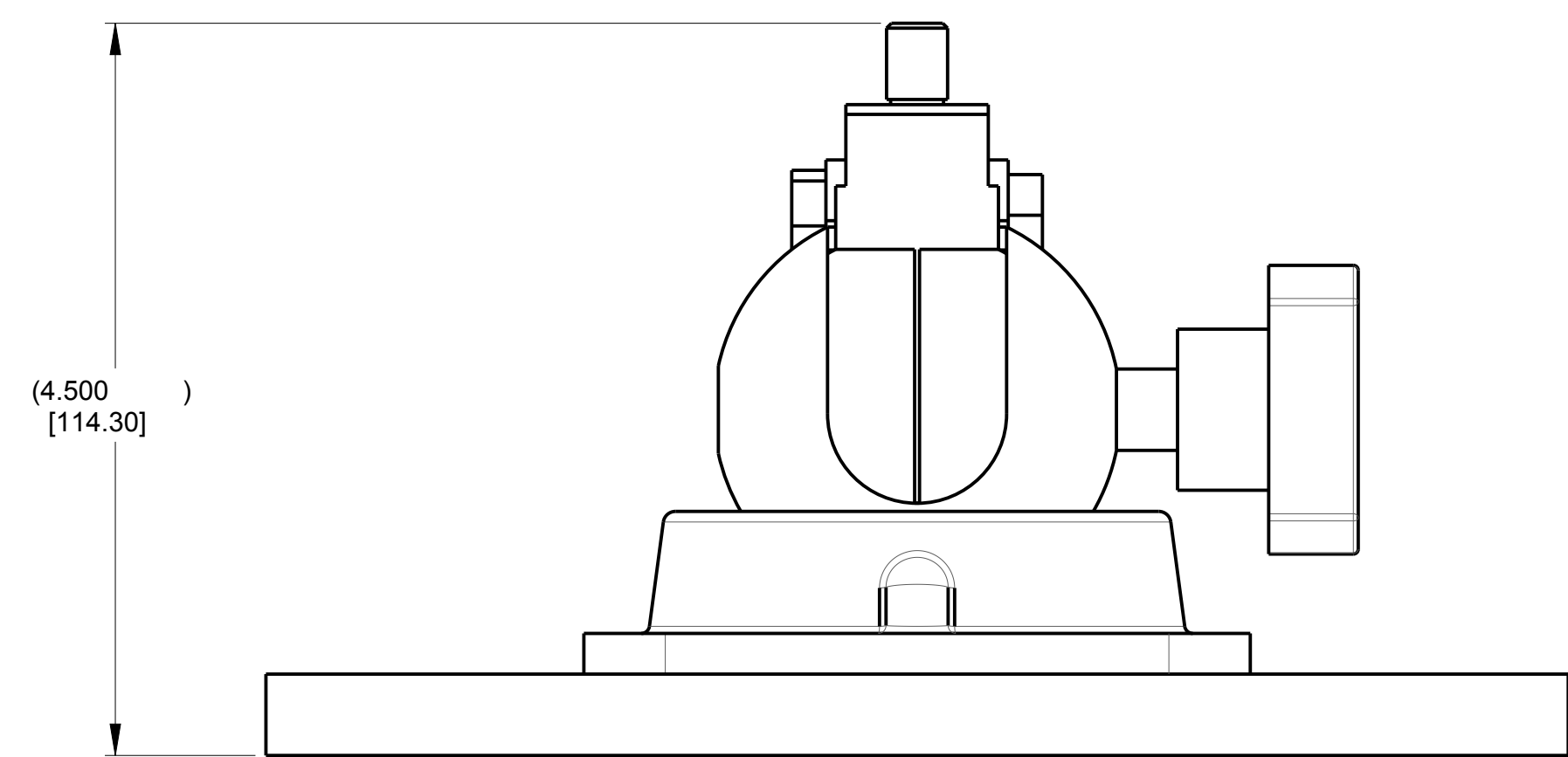

B

B

A

A

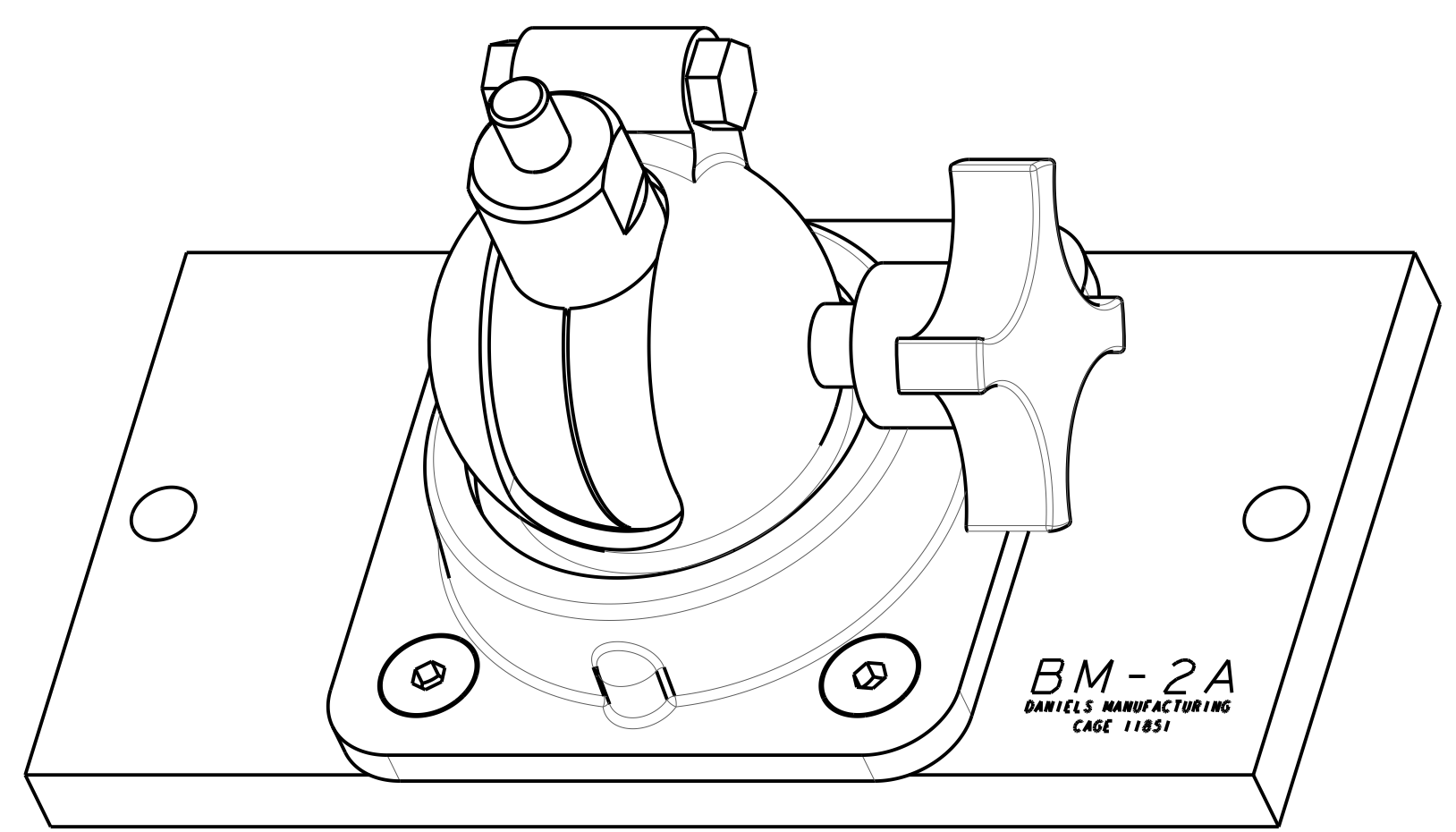

OPTIONAL BASE MOUNT

NOTES:

SIGNATURE & DATE		TOOL, PNEUMATIC CRIMP FOR SIZE 20, 16 & 12 SOLID CONTACTS	EP	MATL. CODE
DR	J.APOSTOL 25APR2012		3850 INDUSTRIAL AVE. HEMET, CA 92545	
CHK	D. MEYER 2/21/13		DEUTSCH INDUSTRIAL	
PE	D. MEYER 2/21/13		C PDT-48-00	
APPD	D. MEYER 2/21/13	ENVELOPE	DWG SIZE	CODE 11139
SCALE	NONE	WT	SHEET 2 OF 2	

7

6

5

4



3

2

1