

DAQ on a Stick, Renesas Strain Gauge

Introduction

The “DAQ on a Stick, Renesas Strain Gauge” is one of a series of reference designs highlighting Intersil’s precision products with different microcontrollers. This reference design is a self contained demo showing a complete signal chain solution using Intersil parts and a Renesas microcontroller. The complete reference design is conveniently housed in a USB stick form factor. This compact design draws power through the USB port and uses a Graphical User Interface (GUI) to display the real time voltage readings from a bridge strain gauge or a user supplied sensor. Figure 1 shows the Data Acquisition (DAQ) on a Stick connected to an external foil strain gauge.

Figure 2 shows a simplified schematic of the Strain Gauge design. The design uses Intersil’s ISL28134 chopper amplifier, ISL22316 Digitally Controlled Potentiometer (DCP), ISL43741 differential mux, ISL21010 4.096 voltage reference, the ISL26102 24-bit delta sigma converter and Renesas R5F10JBC microcontroller.



FIGURE 1. DAQ ON A STICK WITH STRAIN GAUGE

Ordering Information

PART NUMBER	DESCRIPTION
ISLRE-BDGSTKEV2Z	Evaluation Board

Getting Started

Installation of the Graphical User Interface (GUI) Software and USB Drivers

The GUI Software and USB drivers have to be installed on a PC running Windows NT/2000/XP/Vista/Win7/Win 8 operating system before connecting the ISLRE-BDGSTKEV2Z evaluation board to the USB port.

The software and a quick video on the operation of this application demo can be downloaded or viewed from the Intersil website at <http://www.intersil.com/en/tools/reference-designs/Renesas-strain-gauge-reference-design.html>.

Loading Software

Click on the Renesas DAQ on a Stick Software link to load the executable. Follow the on-screen instructions to complete the software installation. The installation program places the user interface software in the C:\Program Files\Intersil\RenesasSGDAQonStick directory. To create a shortcut on your desktop, check the “Create A Desktop Icon” box during the software installation. Launch the application by checking the “Launch Intersil Renesas DAQ on Stick” box, then click the “Finish” button.

Video Clip

A quick video clip is also provided at the above web link. This video will walk the user through the operation and use of the GUI.

Running the Evaluation Software

After software has been installed, plug the ISLRE-BDGSTKEV2Z board into a USB port on the computer and click on the Intersil DAQ shortcut (created in the step above) on the desktop. Figure 3 shows the desk top icon.

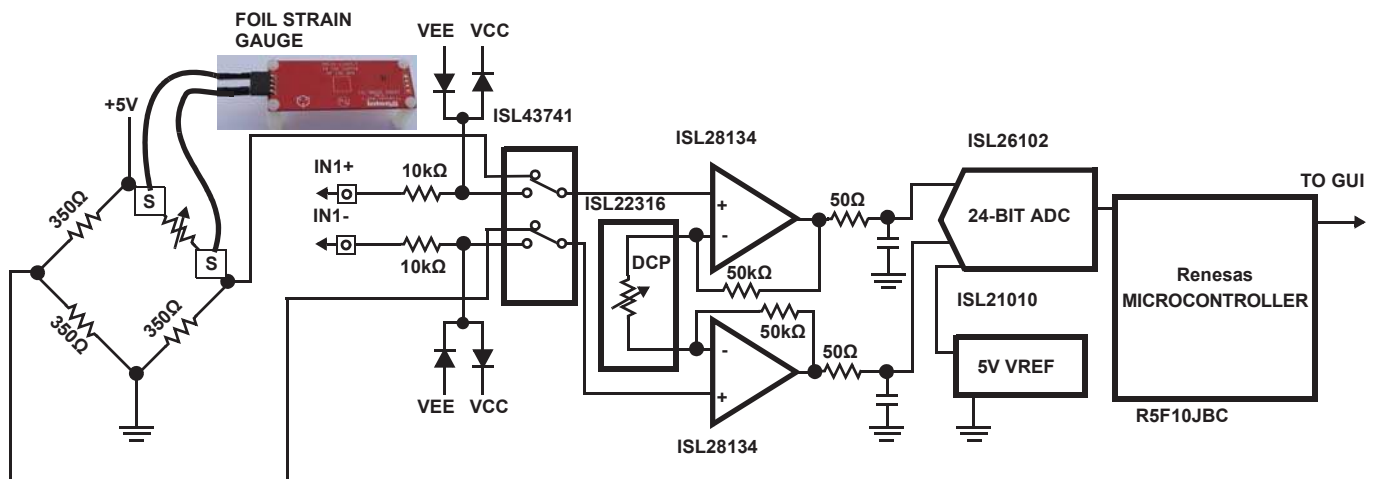

FIGURE 2. SIMPLIFIED STRAIN GAUGE SCHEMATIC

Application Note 1834



FIGURE 3. DESKTOP ICON

The green LED on the DAQ on a Stick board should be on at this time. When the software starts, the DAQ Startup screen shown in Figure 5 will appear. With the DAQ on a Stick connected, the USB Status indicator will display “Connected 0x2032”. The assigned HID code for this application is 0x2032. This is verification the software is communicating with the board.

If the DAQ on a Stick is not connected, or a problem exists with the demo, the message will read “HID Device Not Found”. If this occurs, click on the “Test USB Connection” button to see if this enables the connection. If not, try disconnecting and re-connecting the device or restarting the software.

From the DAQ Start-up Screen (Figure 5), the user can click on the Instantaneous Voltage button to get a single voltage reading, select the sensor input they want to measure and adjust the gain of the amplifier, or click the Start button to go to the Measurement Display screen, as shown in Figure 6. At this point the green LED on the board will go off.

Connecting the Sensor

The ISLRE-BDGSTKEV2Z reference design gives the user the option to measure the strain on a foil gauge (supplied with the evaluation board) or connect their own sensor and monitor the voltage reading on the GUI screen. The user will select the “Sensor Supplied with the Demo” or “Customer Supplied” sensor by clicking the appropriate radial button at the bottom of Figure 5. The foil gauge is the default value in the GUI with a gain

of 115V/V. Figure 4 shows the external connector inputs, which are used to connect the sensor to the circuit shown in Figure 2.

FOIL STRAIN GAUGE

1. To connect the foil gauge supplied with the evaluation board, plug the wires into the “S” ports (either top row or the bottom row, the columns are connected) on the DAQ Stick.
2. Connect the opposite end of the wires to the far edges of the foil gauge board. Reference Figure 5.

USER SUPPLIED SENSOR

1. To connect a user supplied sensor, plug the wires into the IN+ and IN- ports shown in Figure 4, then select the “Customer Supplied” option, as shown in Figure 5. This will cause the ISL43741 differential mux to switch the inputs. Once the customer supplied option is selected, the user will have the option of changing the amplifiers’ gain for the best measurement.
2. The DAQ on a Stick also provides a 5V supply and Ground connection for possible use by the customer’s sensor network.

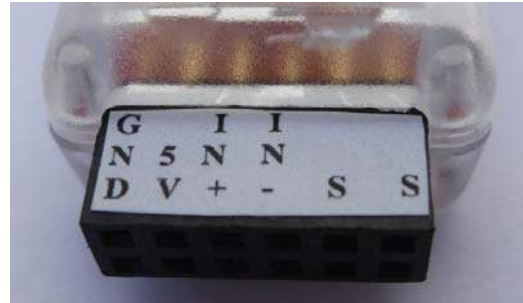

FIGURE 4. SENSOR CONNECTOR

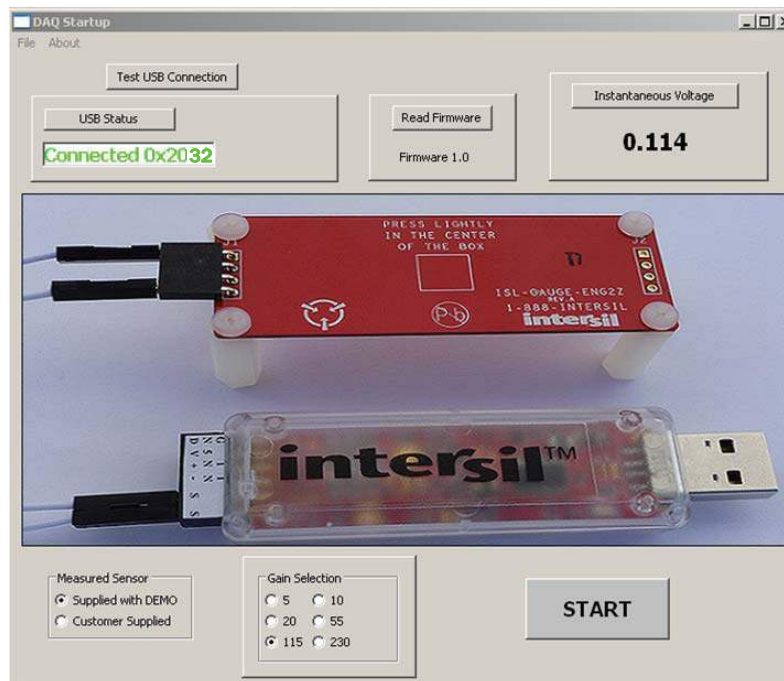

FIGURE 5. GUI START-UP SCREEN

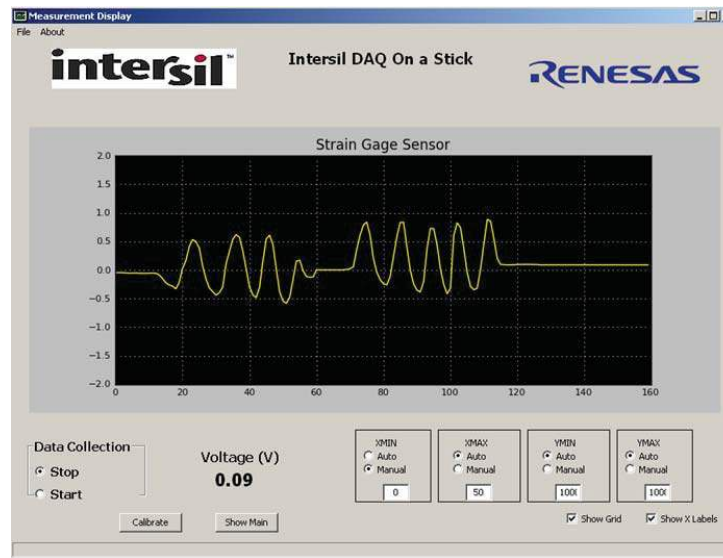

FIGURE 6. GUI MEASUREMENT SCREEN

Figure 6 shows the Measurement Display screen. From this screen, the user can stop and start data collection, adjust the minimum and maximum X & Y axis and go back to the set-up screen by clicking on the Show Main button. A calibrate button is provided to zero out the voltage reading when the board is not under strain. This helps to give an accurate reading from time zero, and is required because the board does not always return to the same deflection point after a strain is applied to the board.

Design Considerations

ISL28134

The ISL28134 is an ideal choice for the input amplifier for a strain gauge design. The ISL28134 uses auto-correction circuitry to provide ultra low offset voltage (2.5 μ V), and low offset temperature drift (15nV/ $^{\circ}$ C). The very low 1/f noise corner <0.1Hz and low input noise voltage (8nV/ $\sqrt{\text{Hz}}$ @ 100Hz) of the amplifier makes it ideal for low frequency precision applications requiring very high gain and low noise. Other attributes of the ISL28134 are the wide gain bandwidth and rail-to-rail input/output swing.

ISL26102 24-bit ADC

The ISL26102 is a complete analog front-end with dual differential multiplexed inputs for high resolution measurements. ISL26102 features a third order modulator providing up to 21.4-bit noise-free performance (10Sps). The 24-bit delta-sigma analog-to-digital converter includes a very low-noise amplifier with programmable gain. Although this application demo uses an input buffer amplifier (ISL28134), the high input impedance of the ISL26102 allows direct connection of sensors, such as load cell bridges to ensure the specified measurement accuracy without a buffer amplifier.

In order to initiate a correct power-up reset, diode D1, resistor R3 and capacitor C8 implement a simple RC delay to ensure the PDWN transitions from low to high after both power supplies have settled to specified levels.

ISL21010 (4.096V)

The ISL21010CFH341 is a precision 4.096V, low dropout micropower bandgap voltage reference. It provides a $\pm 0.2\%$ accurate reference. The ISL21010 provides up to 25mA output current sourcing with low 150mV dropout voltage. The low supply current and low dropout voltage combined with high accuracy make the ISL21010 ideal for precision low powered applications.

ISL22316 DCP

The ISL22316 is a low noise, low power I²C™ bus, 128 tap DCP. The DCP can be used as a three-terminal potentiometer or as a two-terminal variable resistor in a wide variety of applications including control, parameter adjustments, and signal processing.

ISL43741 Diff 4 to 1 Multiplexer

The ISL43741 is a precision, bidirectional, differential 4-channel multiplexer/demultiplexer. The mux is designed to operate from a single +2V to +12V supply or from ± 2 V to ± 6 V supplies. The ISL43741 has low charge injection with 1pC (Max) at $V_S = \pm 5$ V.

Reference Documents

- Intersil ISL28134 Data Sheet “5V Ultra Low Noise, Zero Drift Rail-to-Rail Precision Op Amp,” [FN6957](#)
- Intersil ISL21010 Data Sheet “Micropower Voltage Reference,” [FN7896](#)
- Intersil ISL26102 Data Sheet “Low-Noise 24-bit Delta Sigma ADC,” [FN7608](#)
- Intersil ISL43741 Data Sheet “Low-Voltage, Single and Dual Supply, 8 to 1 Multiplexer and Differential 4 to 1 Multiplexer,” [FN6053](#)
- Intersil ISL22316 Data Sheet “Low Noise, Low Power I²C® Bus, 128 Taps,” [FN6186](#)
- Renesas R5F10JBC [Data Sheet](#)

Application Note 1834

Bill of Materials

PART NUMBER	REF DES	QTY	VALUE	TOL	VOLTAGE	PWR	PACKAGE TYPE	JEDEC TYPE	MFR	DESCRIPTION
GRM21BR71C475KA73L	C1	1	4.7µF	10%	16V		805	CAP_0805	MURATA	CERAMIC CAP
H1044-00103-16V10	C7, C12, C13, C20	4	0.01µF	10%	16V		402	CAP_0402	GENERIC	Multilayer Cap
H1044-00104-16V10	C5, C8, C9, C11, C14, C25, C27	7	0.1µF	10%	16V		402	CAP_0402	GENERIC	Multilayer Cap
H1045-00103-25V10	C16, C19, C21, C22	4	0.01µF	10%	25V		603	CAP_0603	GENERIC	Multilayer Cap
250R07C100JV4T	C23, C24	2	10pF	5%	25V		402	CAP_0402RF	Johanson-Tech	C Series High-Q Chip Cap
H1045-00105-16V20	C2, C3, C10, C26	4	1µF	20%	16V		603	CAP_0603	GENERIC	Ceramic Cap
H1045-00334-25V10	C6	1	0.33µF	10%	25V		603	CAP_0603	GENERIC	Multilayer Cap
H1045-OPEN	C17, C18	2	OPEN	5%	OPEN		603	CAP_0603	GENERIC	Multilayer Cap
H1046-00225-16V10	C15	1	2.2µF	10%	16V		805	CAP_0805	GENERIC	Multilayer Cap
H1065-00106-16V10	C4	1	10µF	10%	16V		1206	CAP_1206	GENERIC	Multilayer Cap
597-3311-407	D1	1					SMD	DIA_LED1206	Dialight	Surface Mount Green LED
BAT54	D2	1					SINGLE	SOT23	DIODES	30V SCHOTTKY DIODE
MMSD4148T1	D3 - D6	4					SOD123	SOD123	ON-Semi	Switching Diode
48037-1000	J1	1					MOLEX1	CON_USB_MOLEX_480371000	MOLEX	Right Angle USB A-Type Receptacle
PPPC062LJBN-RC	J2	1					DIP	CONN12	SULLINS	12 Pin Header 2.54mmx2.54mm (.100) Connector RA
251206102Y1	L1	1	1µH				SMD	SM1210	FAIR-RITE	FERRITE BEAD
H2510-00R00-1/16W	R7, R11, R27	3	0	0%		1/16W	402	RES_0402	GENERIC	Thick Film Chip Resistor
H2510-01000-1/16W1	R2, R3	2	100	1%		1/16W	402	RES_0402	GENERIC	Thick Film Chip Resistor
H2510-01001-1/16W1	R8	1	1k	1%		1/16W	402	RES_0402	GENERIC	Thick Film Chip Resistor
H2510-01002-1/16W1	R1, R4, R15, R16	4	10k	1%		1/16W	402	RES_0402	GENERIC	Thick Film Chip Resistor
H2510-02200-1/16W1	R28	1	220	1%		1/16W	402	RES_0402	GENERIC	Thick Film Chip Resistor
H2510-04991-1/16W1	R5, R6	2	4.99k	1%		1/16W	402	RES_0402	GENERIC	Thick Film Chip Resistor
H2510-04992-1/16W1	R12, R13	2	49.9k	1%		1/16W	402	RES_0402	GENERIC	Thick Film Chip Resistor
H2510-049R9-1/16W1	R9, R10	2	49.9	1%		1/16W	402	RES_0402	GENERIC	Thick Film Chip Resistor
H2510-DNP-DNP-1	R14	1	DNP	1%		DNP	402	RES_0402	GENERIC	Thick Film Chip Resistor (Do Not Populate)
H2512-00010-1/10WR1	R20, R23, R26	3	1	0.1%		1/10W	805	RES_0805	GENERIC	Thick Film Chip Resistor
H2512-01000-1/10WR1	R19, R22, R25	3	100	0.1%		1/10W	805	RES_0805	GENERIC	Thick Film Chip Resistor
H2512-02490-1/10WR1	R18, R21, R24	3	249	0.1%		1/10W	805	RES_0805	GENERIC	Thick Film Chip Resistor

Bill of Materials (Continued)

PART NUMBER	REF DES	QTY	VALUE	TOL.	VOLTAGE	PWR	PACKAGE TYPE	JEDEC TYPE	MFR	DESCRIPTION
ISL26102AVZ	U1	1					TSSOP	TSSOP24_173_256	INTERSIL	24 Pin 173 Mil TSSOP Package
ISL21010CFH341Z	U2	1					SOT	SOT23-3	GENERIC	3 PIN SOT23-3 PACKAGE
ISL28134FHZ	U3	1					SMD	SOT23-5	GENERIC	5 Pin SOT23 Package
ISL28134FHZ	U4	1					SMD	SOT23-5	GENERIC	5 Pin SOT23 Package
ISL43741IRZ	U5	1					QFN	QFN20_157X157_197_EP	INTERSIL	20 LEAD QUAD FLAT PACKAGE (Pb-FREE)
ISL22316UFRT	U6	1					DFN3X3B	TDFN10_118X118_197_EPB	GENERIC	10 Lead 3 X 3 0.5 Pitch Thin Dual Flat Package with E-Pad
R5F10JBCANA	U7	1					QFN-S	QFN32_197X197_197_EPA	INTERSIL	32 LEAD QUAD FLAT PACKAGE (Pb-FREE)
IP4220CZ6	U8	1					SOT457	SOT457	NXP	Dual USB 2.0 Integrated ESD Protection
ISL54055IRUZ	U9	1					1_2X1A	UTDFN6_47X39_157_A	GENERIC	6 PIN UTDFN-1.2X1A 0.4 Pitch Package
ISL21010CFH333Z	U10	1					SOT	SOT23-3	GENERIC	3 PIN SOT23-3 PACKAGE
MCR03EZPF3001	R17	1	3k	1%		1/10W	603	RES_0603	ROHM	Metal Film Chip Resistor
PAD_50	P1, P2	2					THOLE	PAD-50	GENERIC	0.050 Pad with 0.031 Plated Thru Hole
NX5032GA-12.000M-LN-CD-1	Y1	1					SM	XTAL_NX5032GA	NDK	12.000MHz SM Crystal

ISLRE-BDGSTKEV2Z Evaluation Board Layout

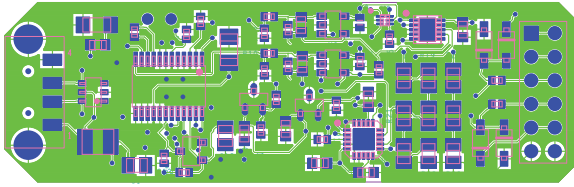

FIGURE 7. TOP LAYER

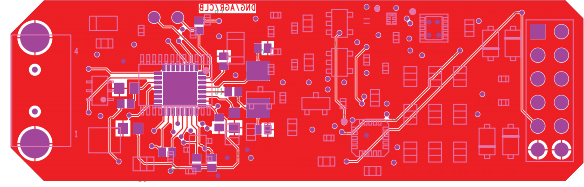
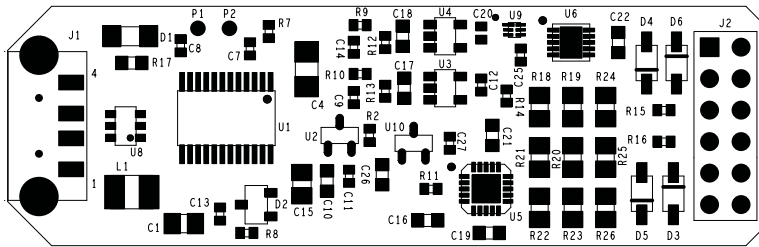
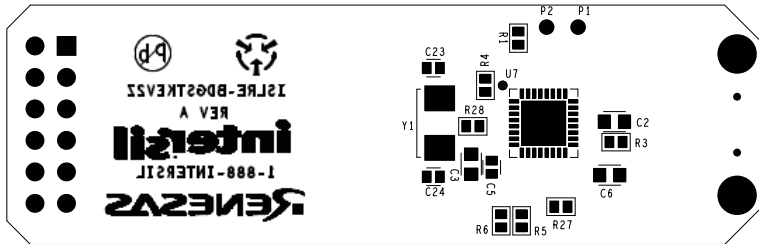

FIGURE 8. BOTTOM LAYER



TOP ASSEMBLY DRAWING



BOTTOM ASSEMBLY DRAWING

FIGURE 9. ASSEMBLY DRAWING

Intersil Corporation reserves the right to make changes in circuit design, software and/or specifications at any time without notice. Accordingly, the reader is cautioned to verify that the Application Note or Technical Brief is current before proceeding.

For information regarding Intersil Corporation and its products, see www.intersil.com

ISLRE-BDGSTKEV2Z Schematic

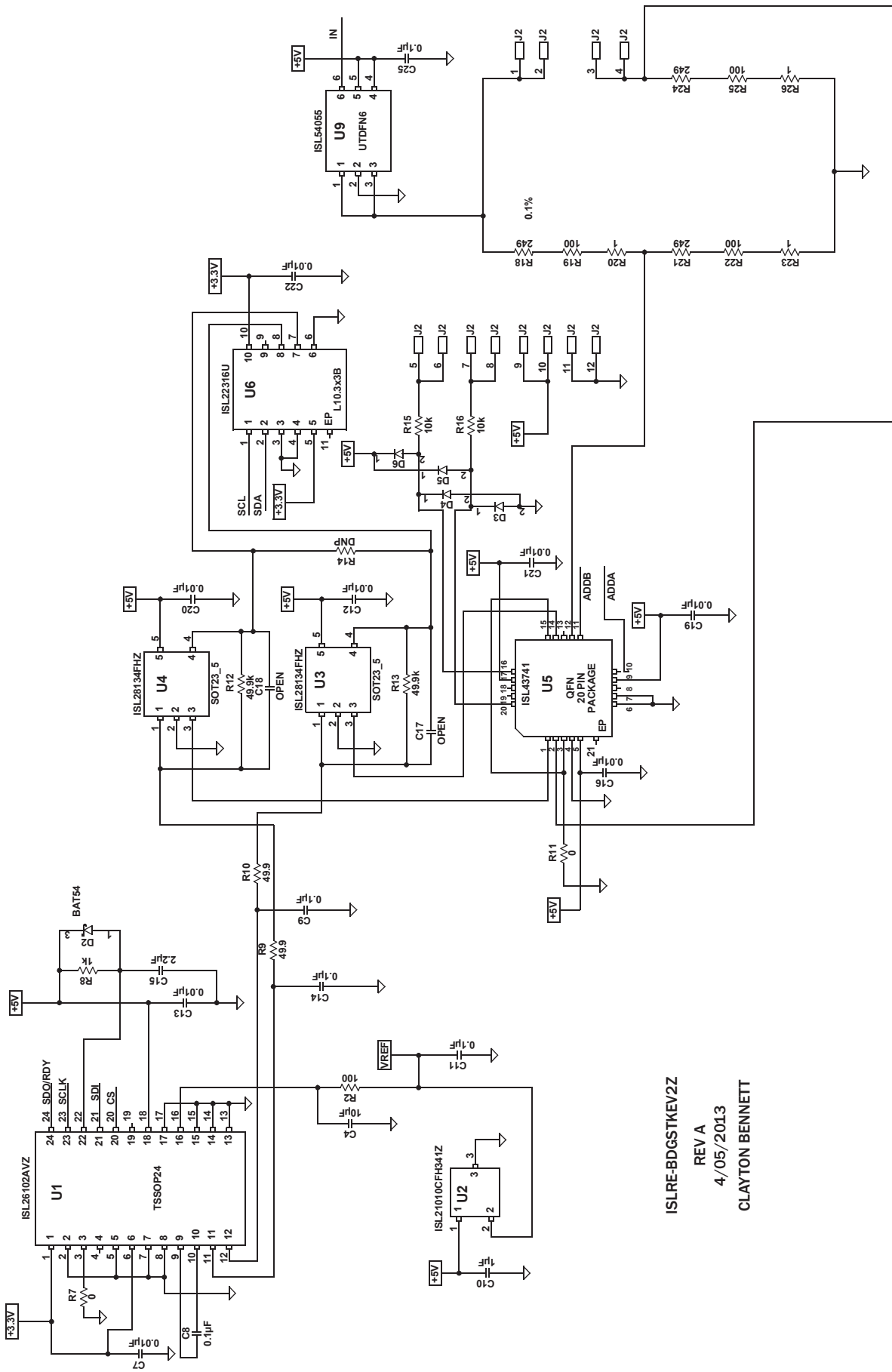

ISLRE-BDGSTKEV2Z
REV A
4/05/2013
CLAYTON BENNETT

FIGURE 10. ISLRE-BDGSTKEV2Z STRAIN GAUGE SCHEMATIC

