

P	LTR	DESCRIPTION	DATE	DWN	APVD
A		RELEASE TO PRODUCTION	26AUG2019	AY	PS
A1		REMOVED TOLERANCE FROM DIM F	17DEC2019	AY	PS

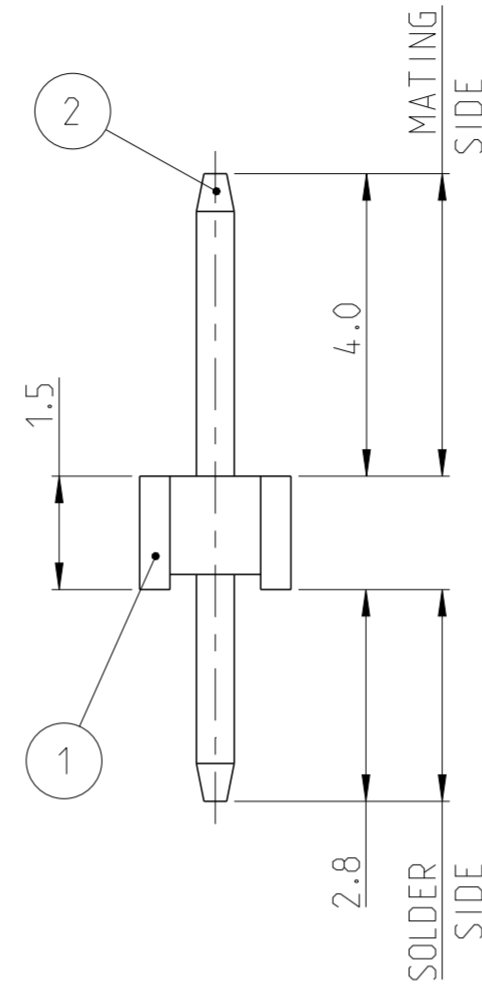

- NOTES:
- MATERIAL
HOUSING : HIGH TEMPERATURE THERMOPLASTIC, UL94-V0; COLOR- BLACK
POST : COPPER ALLOY
FINISH :
MATING SIDE: MIN. 0.1µm GOLD OVER NICKEL UNDER PLATING
SOLDER SIDE: MIN. 2.0µm BRIGHT TIN OVER NICKEL UNDER PLATING
 - PACKAGING: TUBE.
 - TOLERANCE NOT CUMULATIVE.
 - CUTTING BURR MAX. 0.25 mm.

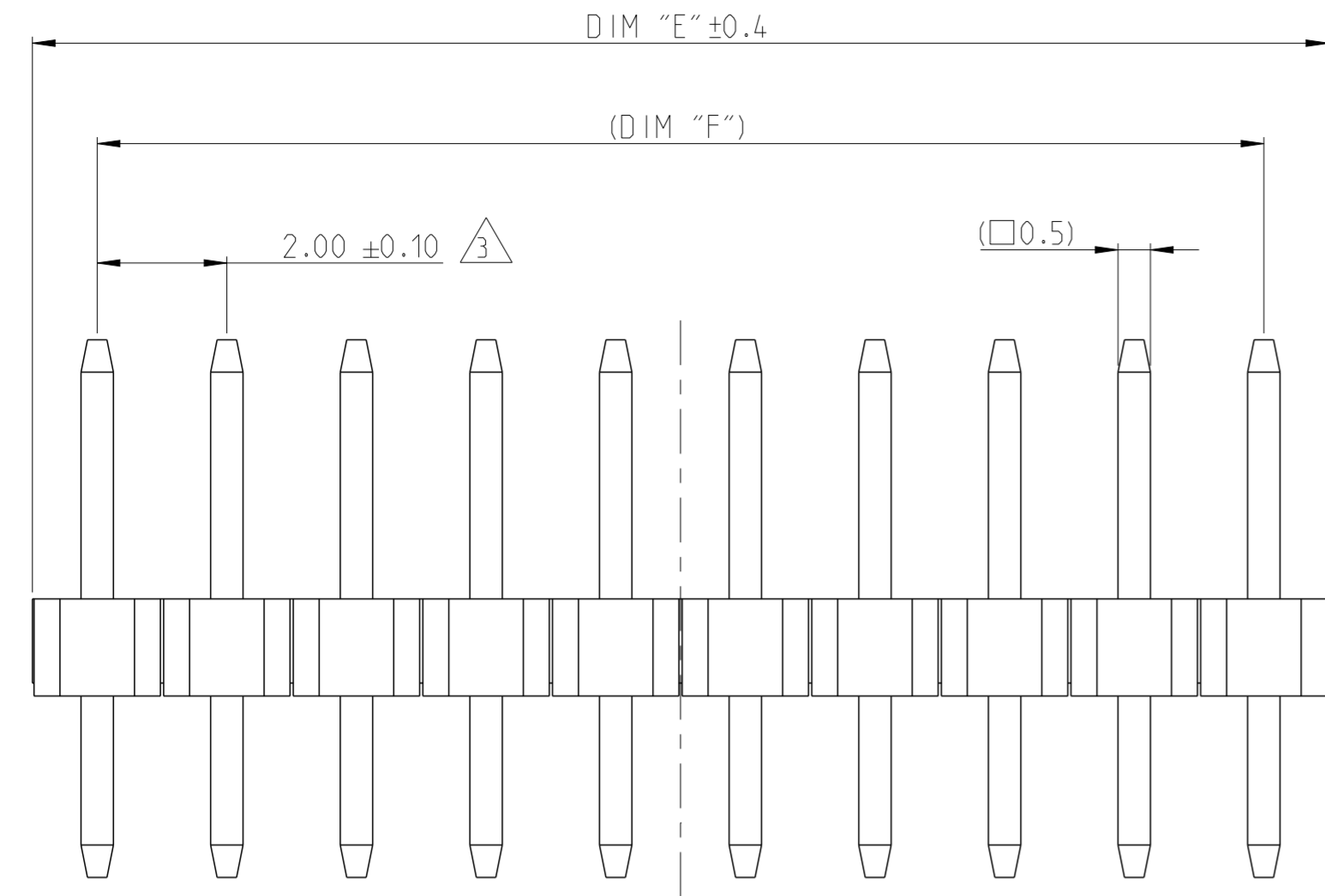
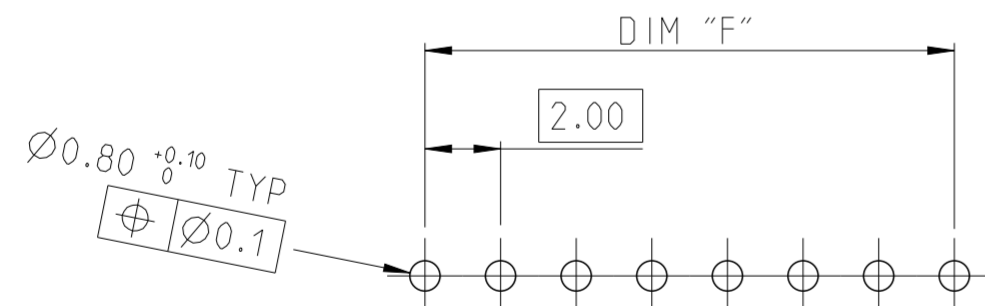
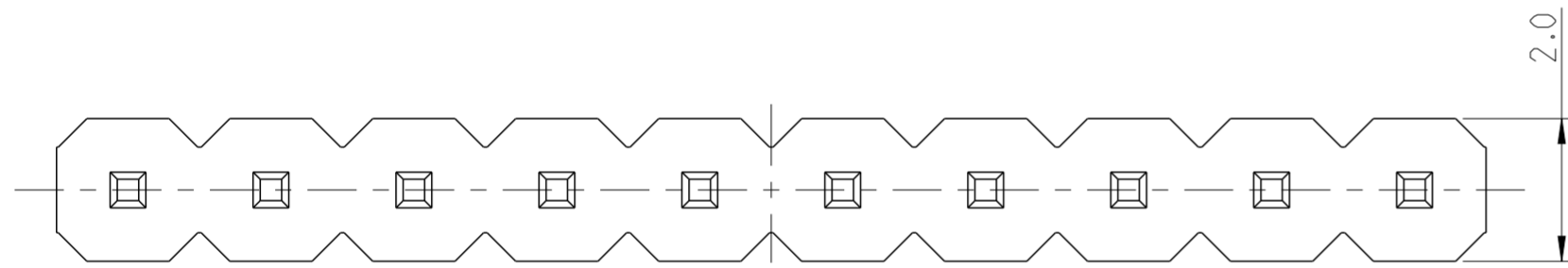

RECOMMENDED PCB HOLE PATTERN FOR THROUGH HOLE WAVE

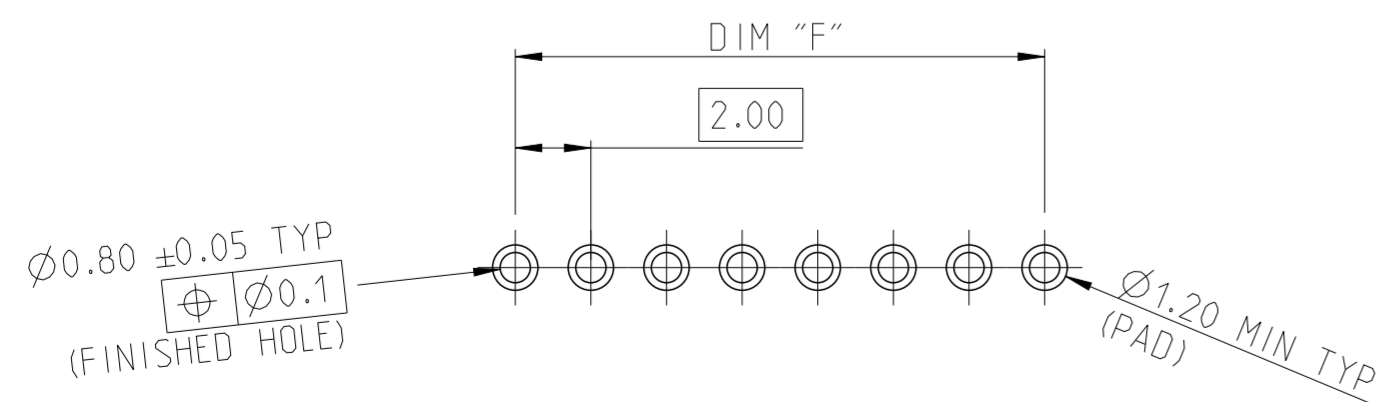

RECOMMENDED PCB HOLE PATTERN FOR THROUGH HOLE REFLOW / PIN-IN-PASTE

1-2355045-0 AS SHOWN

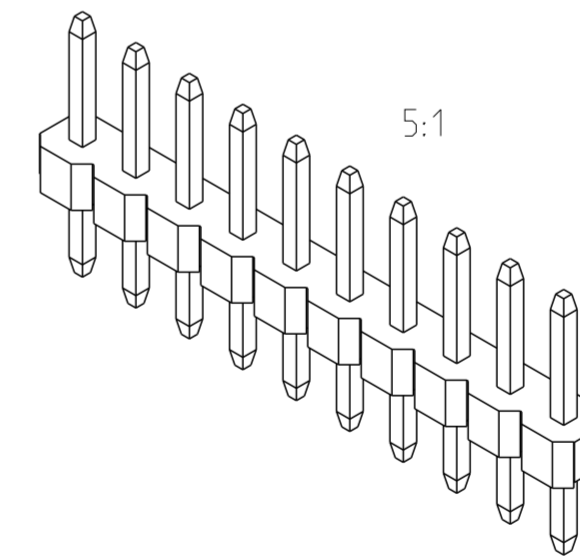

48.0	50.0	25	2-2355045-5
46.0	48.0	24	2-2355045-4
44.0	46.0	23	2-2355045-3
42.0	44.0	22	2-2355045-2
40.0	42.0	21	2-2355045-1
38.0	40.0	20	2-2355045-0
36.0	38.0	19	1-2355045-9
34.0	36.0	18	1-2355045-8
32.0	34.0	17	1-2355045-7
30.0	32.0	16	1-2355045-6
28.0	30.0	15	1-2355045-5
26.0	28.0	14	1-2355045-4
24.0	26.0	13	1-2355045-3
22.0	24.0	12	1-2355045-2
20.0	22.0	11	1-2355045-1
18.0	20.0	10	1-2355045-0
16.0	18.0	9	2355045-9
14.0	16.0	8	2355045-8
12.0	14.0	7	2355045-7
10.0	12.0	6	2355045-6
8.0	10.0	5	2355045-5
6.0	8.0	4	2355045-4
4.0	6.0	3	2355045-3
2.0	4.0	2	2355045-2
DIM "F"	DIM "E"	POS	TE PN

THIS DRAWING IS A CONTROLLED DOCUMENT.

DIMENSIONS: mm

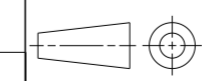

TOLERANCES UNLESS OTHERWISE SPECIFIED:

0 PLC	±
1 PLC	±0.2
2 PLC	±0.15
3 PLC	±
4 PLC	±
ANGLES	±2°
FINISH	

DWN 09APR2019
RAGHAVENDRA.K
CHK 14AUG2019
KARTHIK.JK
APVD 16AUG2019
PRASHANTH
PRODUCT SPEC

108-64040
APPLICATION SPEC
114-32259

WEIGHT -
CUSTOMER DRAWING

NAME		SIZE		CAGE CODE	DRAWING NO	RESTRICTED TO
AMPMODU 2mm BREAKAWAY HEADER, SINGLE ROW, VERTICAL, Au FLASH, TUBE		A2		100779	C-2355045	-
SCALE 10:1		SHEET 1 OF 1		REV A1		