

THIS DRAWING IS UNPUBLISHED. RELEASED FOR PUBLICATION 20
 © COPYRIGHT 20 BY - ALL RIGHTS RESERVED.

LOC	DIST	REVISIONS					
CE	00	P	LTR	DESCRIPTION	DATE	DWN	APVD
		AA		REVISED PER ECR 11-020518	24OCT2011	DLF	SB
		AB		REV; ECO-14-018518	09DEC2014	GG	TE

PART NUMBER	CONNECTOR TYPE	
503746-1	ST STYLE	
503746-2	FSMA	OBSOLETE
503746-3	FC STYLE	SUPERSEDED BY 503746-7
503746-4	D4 TYPE	OBSOLETE
503746-5	AMP SC	SUPERSEDED BY 503746-7
503746-6	FSD	
503746-7	FC/SC	

- ① BLACK POLISHING BUSHING, ITEM 17, IS USED WITH STAINLESS STEEL AND CERAMIC FERRULES ONLY.
- ② BEIGE POLISHING BUSHING, ITEM 18, IS USED WITH POLYMER FERRULES ONLY.
- ③ DIE SET, ITEM 35, TO BE USED TO CRIMP ST, FSMA & D4 504XXX SERIES CONNECTORS ONLY.
- ④ AMP INSTRUCTION SHEETS AND MANUFACTURERS INSTRUCTION SHEETS.
- ⑤ OPTIONAL SHOULDER STRAP.

SUPERSEDED BY 503746-7
 OBSOLETE
 SUPERSEDED BY 503746-7
OBSOLETE

1	-	-	-	-	-	-	905111-7	LABEL, FC/SC	48
-	1	-	-	-	-	-	905111-6	LABEL, FSD	47
-	-	-	1	-	-	-	905111-4	LABEL, D4 TYPE	46
-	-	-	-	-	1	-	905111-2	LABEL, FSMA	45
-	-	-	-	-	-	1	905111-1	LABEL, ST STYLE	44
-	4	-	-	-	-	-	502023-1	ASSY FIXTURE KIT, FSD	43
-	-	-	-	-	-	-	-	-	-
1	-	-	-	-	-	-	1754636-1	STRIP CARD, FC/SC	41
-	-	-	1	-	-	-	492117-1	STRIP CARD, D4	40
-	1	-	-	-	-	-	503479-1	STRIP CARD, FSD, POLY	39
-	1	-	-	-	-	-	502241-1	STRIP CARD, FSD	38
-	-	-	-	-	1	-	501813-1	STRIP CARD, FSMA	37
-	-	-	-	-	-	1	502791-1	STRIP CARD, ST STYLE	36
-7	-6	-5	-4	-3	-2	-1	PART NUMBER	DESCRIPTION	ITEM NO

-	-	-	-	-	-	1	501814-1	STRIP CARD, ST STYLE	35
1	-	-	-	-	-	-	492025-1	FC/SC DIE SET	34
③	-	-	-	1	-	1	58552-1	HEX DIE SET	33
-	1	-	-	-	-	-	58510-1	FSD DIE ASSEMBLY	32
-	-	1	-	1	-	1	58424-1	DIE SET ASSEMBLY	31
1	-	-	-	-	-	-	58588-1	HAND TOOL FRAME (BLUE)	30
-	1	1	1	1	1	1	1976850-1	HAND TOOL FRAME (BLACK)	29
-	-	-	12	-	-	-	492119-1	CURING SLEEVE, D4	28
10	-	10	-	-	-	-	502656-1	CURING SLEEVE, AMP SC	27
12	-	-	-	12	-	-	502862-2	CURING SLEEVE, FC	26
-	-	-	-	-	3	-	502248-2	CURING SLEEVE, FSMA	25
-	-	-	-	-	-	3	502259-2	CURING SLEEVE, ST STYLE	24
10	-	-	10	10	-	10	501857-2	ALCOHOL WIPE	23
-	1	-	-	-	-	-	501791-1	POLISH BUSH, FSD	22
10	-	10	-	-	-	-	502631-1	POLISH BUSH, AMP SC	21
1	-	-	-	1	-	-	504862-1	POLISH BUSH, FC STYLE	20
-	-	-	1	-	-	-	504741-1	POLISH BUSH, D4 TYPE	19
-	-	-	-	-	1	-	228025-1	POLISH BUSH, FSMA	18
②	-	-	-	-	-	1	503304-2	POLISH BUSH, ST STYLE	17
①	-	-	-	-	-	1	503304-1	POLISH BUSH, ST STYLE	16
10	6	10	6	6	6	6	501473-3	EPOXY APPLICATOR	15
10	10	-	1	1	10	10	228433-7	POLISHING FILM, 1µm	14
5	-	-	-	-	-	-	502748-2	POLISHING FILM, FINAL	13
10	10	1	1	1	10	10	228433-5	POLISHING FILM, 0.3µm	12
10	10	1	1	1	10	10	228433-8	POLISHING FILM, 5µm	11
-	-	1	1	-	10	-	228433-9	POLISHING FILM, 15µm	10
3	-	3	3	3	-	3	501858-1	POLISHING PAD, GREEN	9
-	3	-	-	-	-	1	501523-1	POLISHING PAD, WHITE	8
1	1	1	1	1	1	1	501197-1	POLISHING PLATE	7
1	1	1	1	1	1	1	504064-1	SCRIBE TOOL	6
1	1	1	1	1	1	1	1278637-1	ARAMID SHEARS	5
1	1	1	1	1	1	1	501205-1	WATER BOTTLE	4
1	1	1	1	1	1	1	504024-3	FIBER STRIPPER, .012	3
1	1	1	1	1	1	1	1754708-1	STRIP TOOL, COMBINATION	2
1	1	1	1	1	1	1	1278540-1	PREMIUM SOFTCASE	1
-7	-6	-5	-4	-3	-2	-1	PART NUMBER	DESCRIPTION	ITEM NO

THIS DRAWING IS A CONTROLLED DOCUMENT.

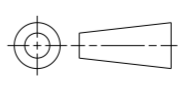
DIMENSIONS: mm	TOLERANCES UNLESS OTHERWISE SPECIFIED:	DWN P. YEAGER 09AUG94	 TE Connectivity		
	0 PLC ±	CHK J. SABO 10AUG94			
	1 PLC ±	APVD K. MONROE 10AUG94			
	2 PLC ±	NAME TERMINATION KIT, OPTIMATE			
3 PLC ±	PRODUCT SPEC	SIZE	CAGE CODE	DRAWING NO	RESTRICTED TO
4 PLC ±	APPLICATION SPEC	A2	00779	C-503746	-
ANGLES ±	MATERIAL	WEIGHT	SCALE	SHEET	OF
FINISH	-	-	1:2	1	2
		Customer Drawing			REV AB

THIS DRAWING IS UNPUBLISHED. RELEASED FOR PUBLICATION 20
 © COPYRIGHT 20 BY - ALL RIGHTS RESERVED.

LOC	DIST	REVISIONS					
CE	00	P	LTR	DESCRIPTION	DATE	DWN	APVD
		-		SEE SHEET 1	-	-	-

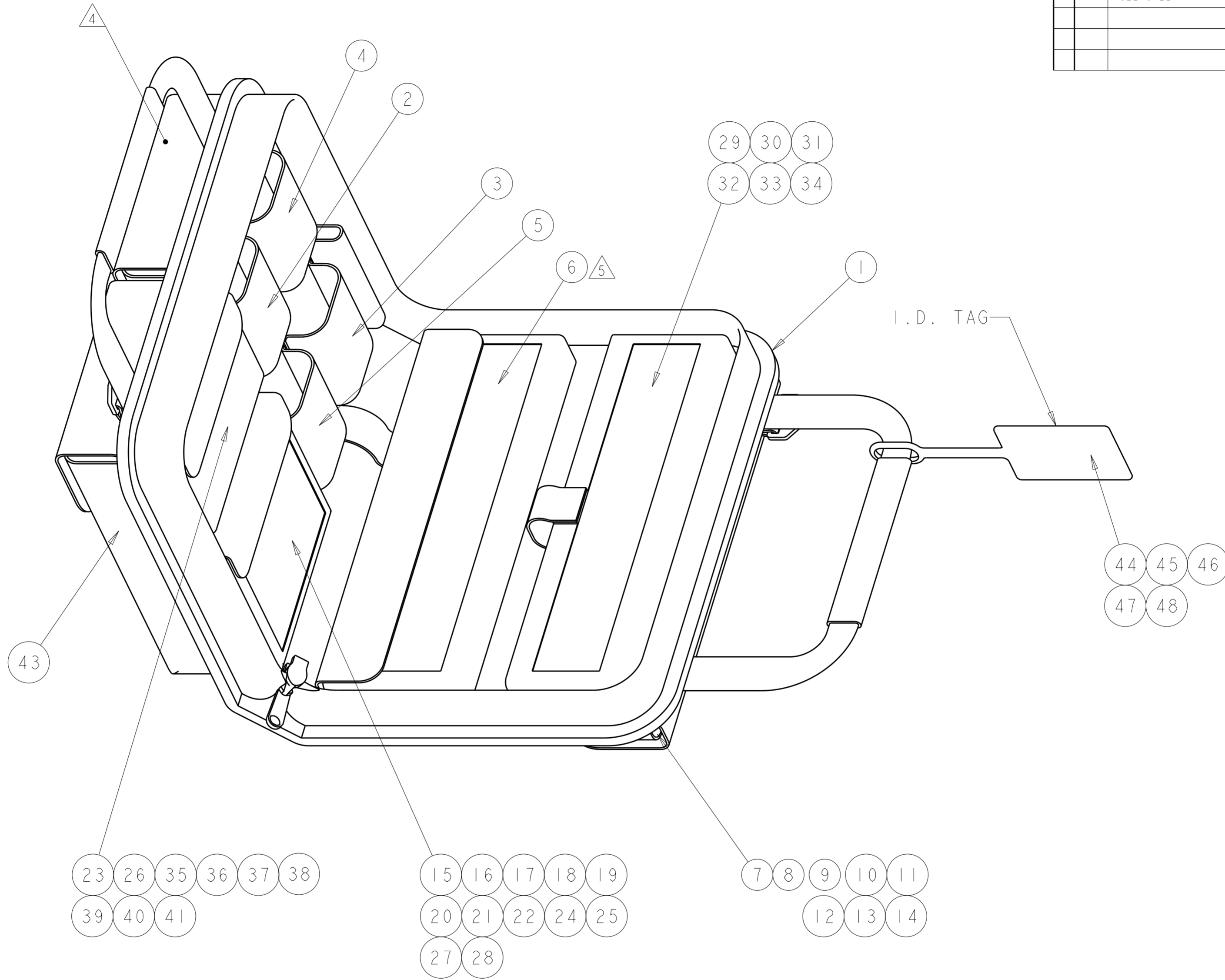

THIS DRAWING IS A CONTROLLED DOCUMENT.		DWN P. YEAGER 09AUG94	STE TE Connectivity	
DIMENSIONS: mm		CHK J. SABO 10AUG94		
TOLERANCES UNLESS OTHERWISE SPECIFIED:		APVD K. MONROE 10AUG94	NAME TERMINATION KIT, OPTIMATE	
0 PLC ±		PRODUCT SPEC	SIZE	
1 PLC ±		APPLICATION SPEC	CAGE CODE	
2 PLC ±		WEIGHT	DRAWING NO	
3 PLC ±			RESTRICTED TO	
4 PLC ±			A200779 C-503746	
ANGLES ±			SCALE 1:2 SHEET 2 OF 2 REV AB	
FINISH				
MATERIAL		Customer Drawing		